

Kit Summary:

Kit #	A1034
Description	C-clip eliminator kit with ball bearing
Applications	small GM housing end with Strange axle factory drum brake 2.8325" F dimension
Page	1 of 2 total pages
Date Modified	Apr 11, 2014

Kit Contents			
ITEM#	PART#	QTY	DESCRIPTION
1	A1030BZ	2	Safety hub outer half
2	A1021	2	Ball bearing
3	A1090C	2	Wedding ring
4	A1030C	2	Seal
5	A1030A	2	Safety hub inner half
6	A1030E	4	Gasket
7	A1030G	2	Safety hub stud
8	S3402N	2	3/8" Washer
9	F1282	2	3/8"-24 Jet Nut
10	A1030D	8	3/8"-16 x 2" HHCS

Housing Preparation

1. Remove wheel and tire, drum and axle from the housing (axle c-clip must be removed first).
2. Disassemble the rear drum kit and remove the studs and backing plate from the housing end flanges.
3. Remove the stock bearing and seal from the housing snouts.
4. Refer to figure 1 and shorten the housing snout leaving the register for the backing plate only.
5. Remove any rust, dirt or grease from the modified housing and both seating surfaces of the backing plate.

Axle Preparation

6. Press the outer hub (1) and ball bearing (2) on the axle in the orientation shown.
 - Note:** Ensure to press only on the inner race.
 - The bearing o-ring must face outboard towards the axle flange as shown in figure 2.
7. Press the wedding ring (3) on the axle.
8. Align the inboard half (4) and axle seal (5) with the outboard half and slide over the axle.

Axle Installation

9. Slide the bolts (10) through the housing end flange.
 - Note:** Use the provided stud (7) instead of the bolt in locations where clearance may be an issue due to the stock shock mount brackets.
10. Re-install the brake backing plate.
 - Note:** Do not install the gaskets. First ensure axle spline engagement following steps below.
11. Coat the spline portion of the axle with white lead compound or grease. This will help determine axle spline engagement.
12. Re-install the axle with the safety hub assembly and rotate the safety hubs to align with the bolts (10).
13. Due to a variety of differentials and gear ratios ensure the axle shafts do not contact the differential cross pin. The axle must be cut if it makes any contact. Contact can be checked by coating the ends of the axle with white lead or grease.
14. Remove the axle from the housing and ensure spline engagement is 1" minimum.
15. Apply thin coating of RTV sealer to both sides of hub gasket (8).
16. Re-install backing plate with gaskets in place.
17. Re-assemble the axle into the housing and torque the housing end bolts (10) to 40 ft-lbs.

FIGURE # 1: Housing modification

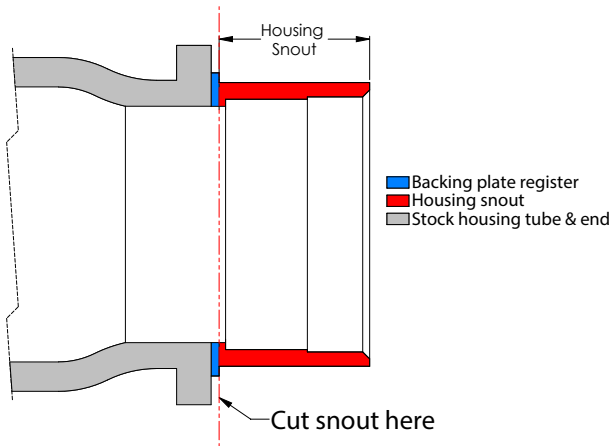

FIGURE # 2: Bearing orientation

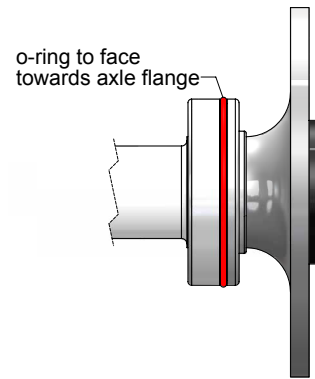

FIGURE # 3: Exploded view

