

Installation Guide

Stowe Cargo Management System

Table of Contents

- 1. Pre-Installation (Page 2)
 - a. Notes, Installation Kit contents & Tools needed
- 2. How to Install the Stowe Cargo Management System (Pages 3-12)

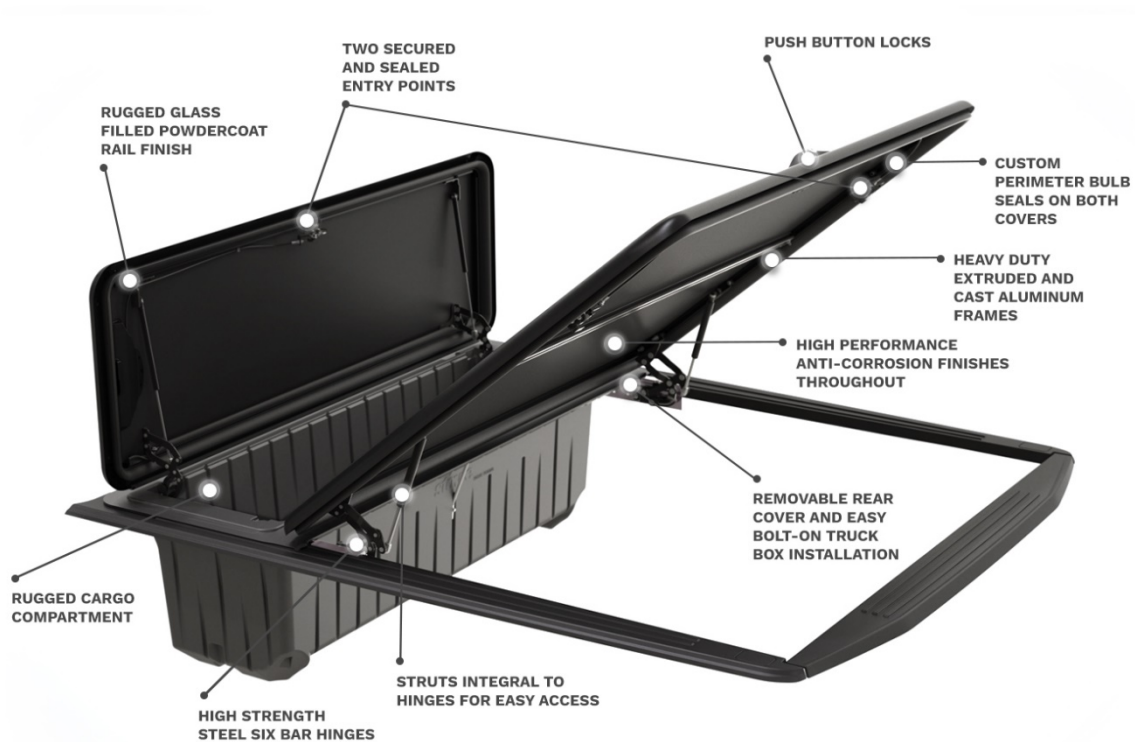

Pre-Installation Notes

- Open all boxes, inspect the contents, and confirm the contents against the parts list below.

Installation Kit Contents

BAG	Cell 1	Cell 2	Cell 3
1	Installation template	Gauge blocks (2)	Cross member stud plates (2), nuts (2)
2	Front hinge spacers (2)	Front hinge bolts (4)	Hinge spacer foam seals (2)
3	Front striker	Striker spacer plate	Striker nuts (2)
4	Rear hinge bolt (2), nuts (2)	Rear hinge stop screws (2)	Pencil brace, bolt, nut
5	Head board seal (1)		
	Front (2), Rear struts (2)		
	Front bedrails (LH/RH)		
	Rear bedrails (LH/RH)		
	Cargo compartment cross member (1)		

Tools Needed



Wrench 10mm

Cross member
Striker
Back plates



Wrench 13mm

Hinges



Wrench 15mm

Support foot



Tape Measure

Rear bed rail
location

Install the Front Bed Rail Assemblies to the Truck

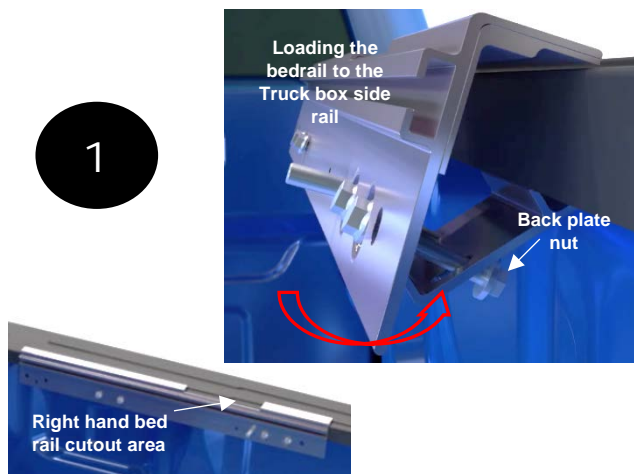

Loosen the back plate nuts to the end of the bolts and load the bed rail to the truck box.

Note: The bed rails are unique to the left and right side of the truck. The cutout in the top flange is to be positioned towards the rear of the truck.

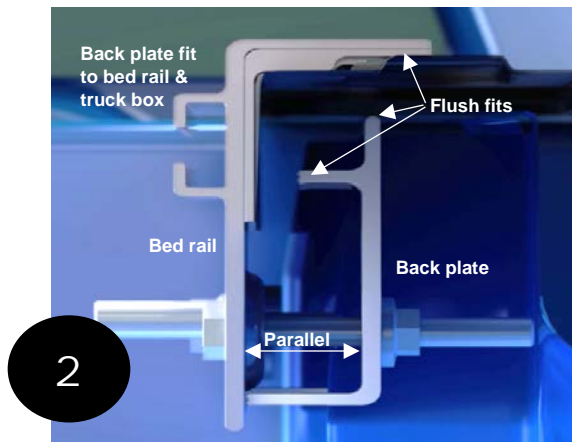

Raise the bed rail back plates until flush with the underside of the truck box while keeping it parallel to the back side of the bed rail.

Hand tighten all fasteners while holding the back plates in position. Ensure that the bed rail remains flush with the top of the truck box.

Note: You may have to remove or displace a truck box rail panel clip to position the back plate.

If you have a 2015 F150 with a drop-in bed liner, a window will have to be cut in the bed liner directly behind the rear back plate to provide clearance.

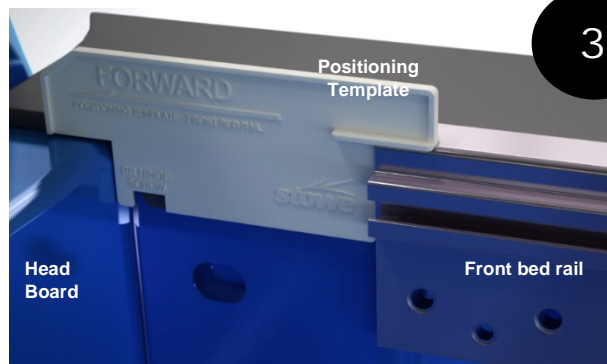

Locate the bed rails using the positioning template.

Position the template between the truck head board sheet metal (not the bed liner) and the front edge of the bed rail. It may be necessary to shift the bed liner slightly to insert the template.

With the template holding the bed rail in position secure the back plate fasteners while maintaining the relationship between the bed rail the back plate and the truck box rail.

After tightening the fasteners, re-confirm the position of the bed rails using the template.

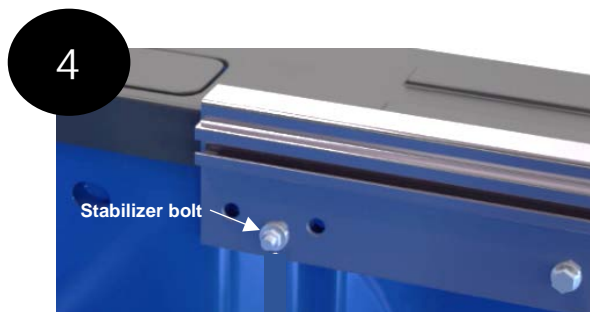

Loosen the jam nut and thread the stabilizer bolt through the bedrail until it firmly contacts the truck sheet metal behind the bedrail.

Tighten the jam nut securing the bolt in place.

Install the Front Bed Rail Cross Member

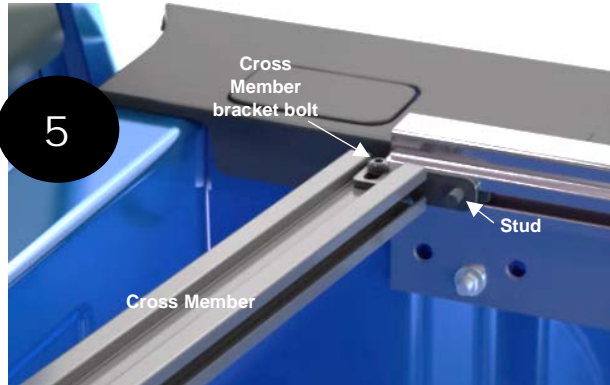

The cross member is installed from the front end of the bed rail at the truck box head board.

Slide a single stud plate into the front end of the channel on both bed rails.

The tab on the cross member bracket faces forward with the stud attachment end at the rear. Position the cross member end bracket over the stud and insert the bracket tab into the bed rail channel.

The cross member may have to be installed at an angle to engage the studs.

Note: The head of the cross member bracket bolt is to be on the top side of the cross member with the studs mounted in the cross member facing forward.

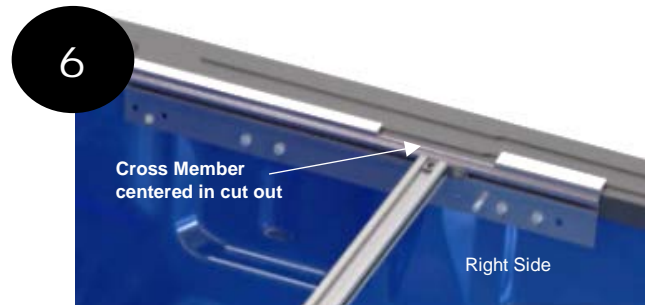

Loose assemble a nut to each stud.

Temporarily position the cross member in the center of the cut out in the bed rail.

Note: Ensure that the end bracket tabs are still engaged in the bed rail channel on both sides.

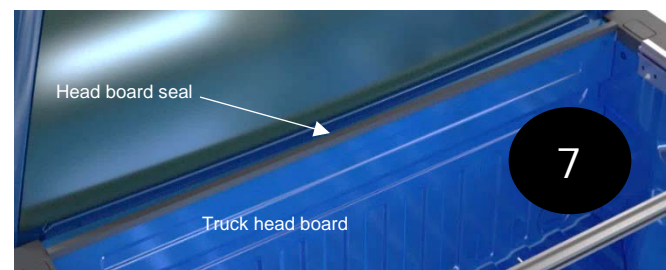

Install the Head Board Seal

Apply the head board seal across the width of the truck box head board trimming the ends as required to fit the seal in between the sides of the truck box side rails.

Apply the seal to the center of the head board. If equipped with a bed liner, the seal is applied to the top surface of the bed liner covering the head board. Remove the liner from the top surface of the seal.

The seal should be slightly higher than the top of the truck box rail when installed.

Note: If you have an aftermarket bed liner on your 07-13 GM or RAM truck which extends above the height of the side rail, the top of the bed liner which wraps over the top of the head board sheet metal will have to be trimmed off.

Install the Cargo Compartment

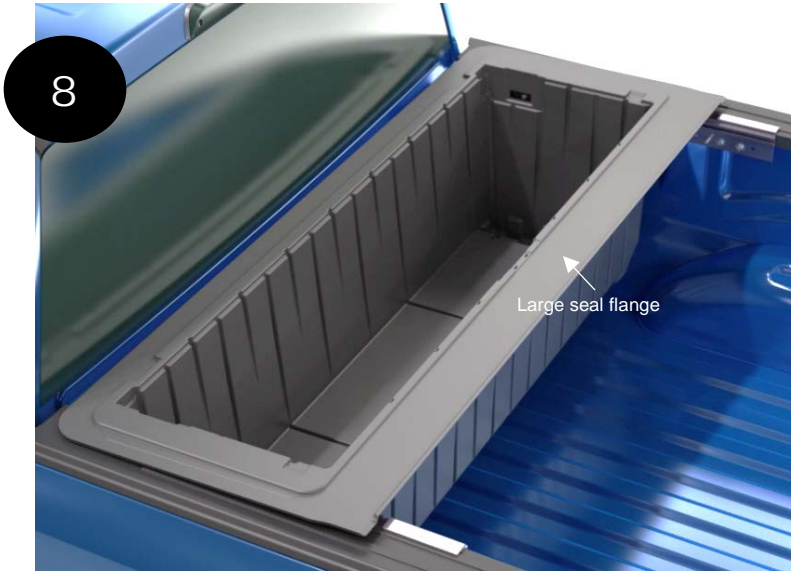

Place the cargo compartment into the front of the truck box. The large seal flange is positioned towards the rear of the truck.

Note: For trucks with a 5.5 box equipped with an aftermarket bed liner check the clearance between the side of the compartment legs and the bed liner to ensure that there is clearance. To correct an interference condition a small flap must be cut in the bed liner. The flap provides the necessary clearance while still maintaining the integrity of the bed liner.

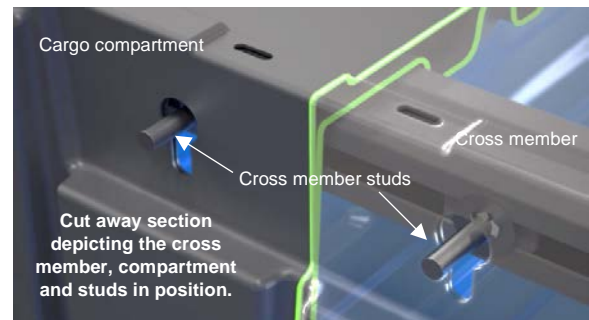

Lift the rear of the compartment upward to allow the cross member to be slid into the channel on the underside of the flange.

Slide the studs in the front of the cross member through the holes in the compartment as the cross member and compartment are brought together. Tip the studs upward to ease assembly.

Note: Ensure that the cross member bracket tabs are still engaged with the bed rail after the cross member is in place.

Install the Cargo Compartment - cont.



To locate the cargo compartment in the correct position relative to the truck box, first align the hinge mounting holes on the both sides of the compartment with the mounting points in the bed rails.

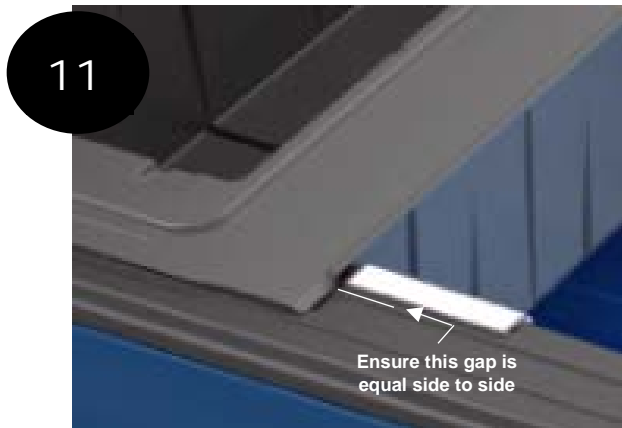

Then ensure that the compartment is positioned evenly side to side by inspecting the relationship between the rear flange and the bed rail on top of the truck box rail.

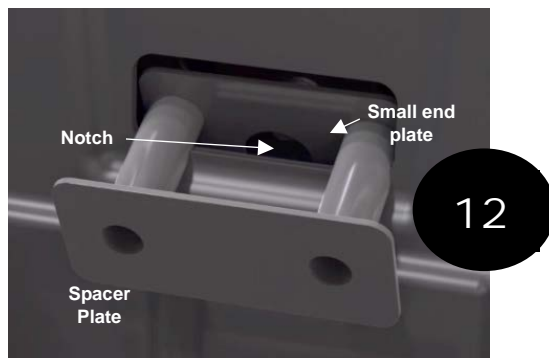

Install the hinge mounting spacers through the compartment wall opening. Accomplish this by tipping and inserting the lower edge of the smaller end plate into the opening and then rotating the plate through the opening. The notch in the smaller end plate must face downward.



Hand start and then remove all four hinge bolts to ensure proper alignment between the spacer and the bed rail.

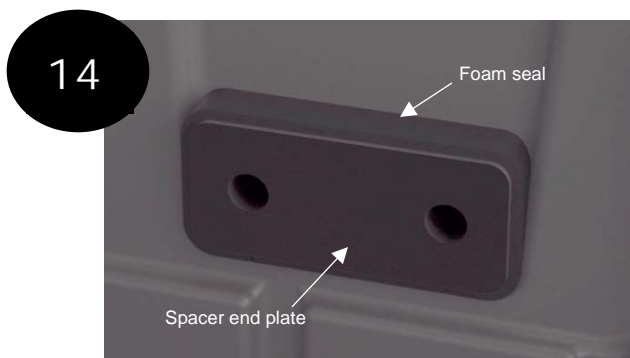

Insert the foam seals between the hinge spacer end plate and the cargo compartment wall. The lower side of the foam spacer will open to allow the seal to pass over the spacer arms.

Install the Front Cover Assembly



Place the front cover mounting blocks in the pockets on either side of the compartment front flange.

Carefully place the cover onto the mounting blocks and open the front hinges. Compress the hinge spacer foam seals to allow the front hinge body bracket to sit against the face of the spacer end plate.

Loose install the hinge mounting bolts on both sides of the cover and then secure. Ensure that the cover remains seated on the mounting blocks as the bolts are tightened.

Remove the mounting blocks.

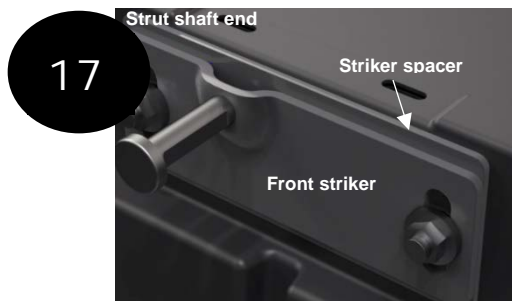

Install the front striker spacer through the rear of the compartment over the exposed cross member studs. Load the front striker to the spacer and hand start the stud nuts.

For ease of assembly start by installing the RH nut onto the longer cross member stud first.

Ensure that the compartment is still positioned correctly side to side, position the striker 1/16" from the top of the spacer plate and secure the mounting nuts.



Install the struts by snapping the strut socket over the ball studs on the hinge and cover. Install the hinge end first.

The strut shaft end is installed downward towards the hinge. You may have to slightly compress the strut to engage the upper ball stud.

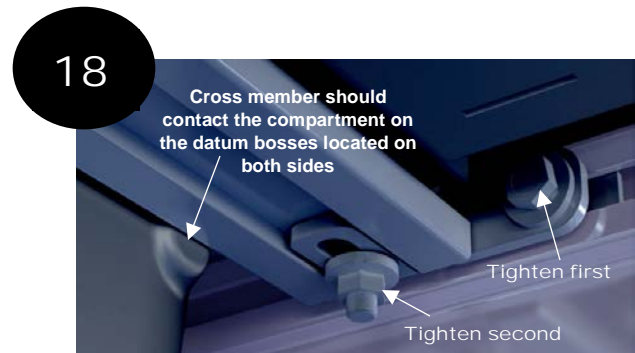

Tightening the striker nuts will firmly seat the cross member against the rear of the cargo compartment.

Ensure that the cross member is evenly contacting the two rear datum bosses and then tighten the cross member end bracket nuts.

First tighten the bed rail attachment point then tighten the nut securing the bracket to the cross member.

Ensure this tightening sequence is followed.

Install the Front Cover Assembly – cont.

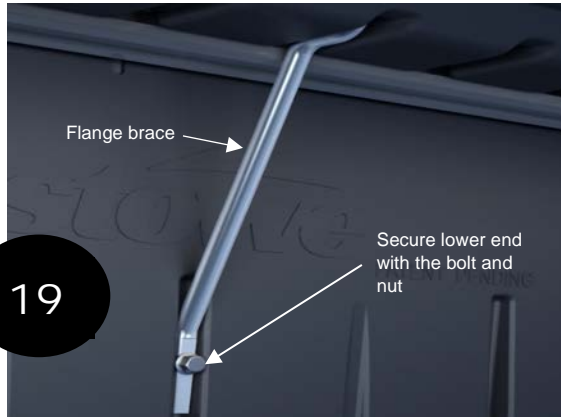

19

Install the cargo compartment rear flange brace by inserting the top end of the brace into the underside of the flange and placing the lower end of the brace against the front face of the cargo compartment.

Install and tighten the bolt and nut to secure the brace in position.



21

Re-position the striker vertically as required to adjust the trim height of the cover along the side of the truck while maintaining the latching function to the striker. The trim height should be even from front to rear looking at the cover side rail on the driver's side.

The latch will not be able to reach the striker if lowered too far.

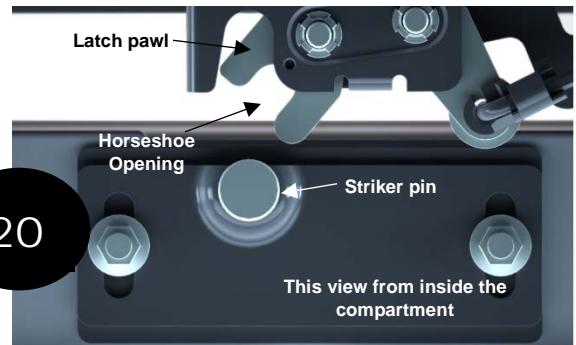

20

Inspect the relationship between latch pawl and the striker as the cover approaches the closed position. The horse shoe shaped opening in the latch pawl should be centered around the striker pin.

If the correct relationship exists between the latch and striker attempt to latch the cover. A misalignment will create a no latch or hard latching condition

If the latch is not aligned side to side the latch bracket will have to be moved on the cover by loosening the two bracket nuts.

Position the Cargo Compartment Support Foot

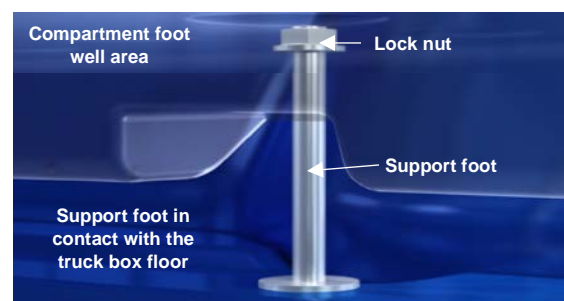

22

Loosen the lock nut and turn the support foot downward until it rests on the floor of the truck box. Retighten the lock nut to secure the support foot in place.

Do not over drive the support foot against the truck box floor. The foot should only rest firmly.

Install the Rear Cover Assembly

For 07-13 GM trucks which are not equipped with factory bed rail covers apply the protective tape provided with your cargo system to the truck bed rail sheet metal as your first step. Refer to the note below for tape application.

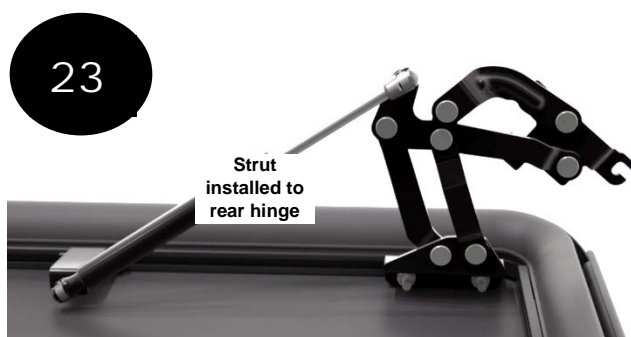

Install the rear struts by snapping the strut sockets over the ball studs on the hinge and cover.

The exposed strut shaft end is installed towards the hinge.



Move the panel forward and insert the body bracket support finger into the channel on each bed rail.

Note: The left and right side support fingers must be inserted simultaneously into the channel to prevent the finger from binding in the channel.

07-13 GM Trucks – cont. from above

Spraying the painted surface with window cleaner will allow you to position the tape. Install from the edge of the cargo compartment to the end of the side rail. Use a razor blade to relieve the tape in the stake pocket area and tailor the end contour.



With the assistance of an associate lift the cover into position just behind the bed rails. Move the cover forward until the hinge body bracket starts to overlap the end of the bed rails.

Watch that the body bracket does not get trapped behind the bed rail.

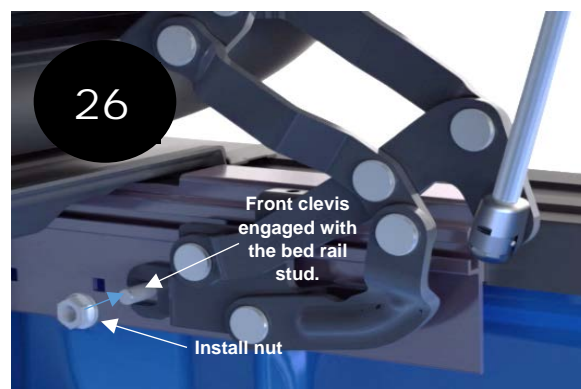

Continue moving the panel forward until the body bracket front clevis engages with and settles over the bed rail stud.

Install and hand tighten the stud nut on both sides of the truck.

You can allow the rear of the panel to rotate downward and rest on the body bracket fingers while preparing to install the rear body bracket bolts.

Install the Rear Cover Assembly – cont.

27

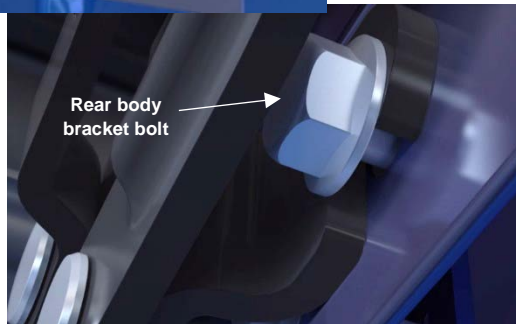
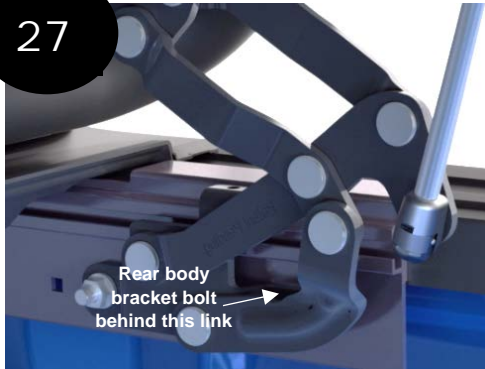

Install the rear body bracket bolts. Slide the bolt upwards through the slot in the body bracket until aligned with the bed rail nut and tighten.

Note: You will need to rotate the cover upward slightly to settle the body bracket clevis onto the front stud while aligning and tightening the bolts.

28



Install the rear hinge stop screw and set the installed height using the cutout in the bed rail installation template.

The threads are coated with a locking material to hold the screw in place.

Install the Rear Bed Rail Assemblies to the Truck Box



The rear bed rails are unique to the left and right side of the truck. Ensure that the striker pin is positioned towards the rear.

Loosen the back plate nuts to the end of the bolts and load the bed rail to the truck box.

Raise the bed rail back plate until flush with the underside of the truck box while keeping it parallel to the back side of the bed rail extrusion.

Hand tighten all fasteners.

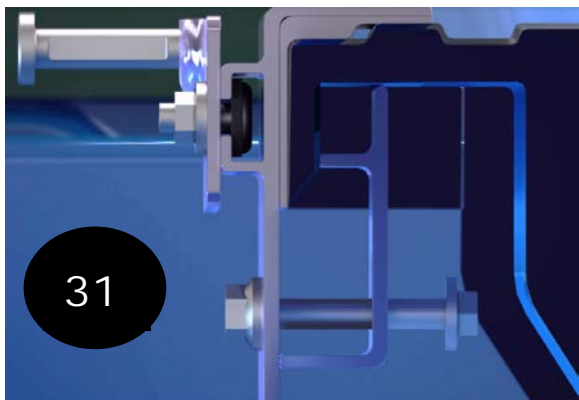

Secure the bed rail fasteners while holding the bed rail and back plate in position.

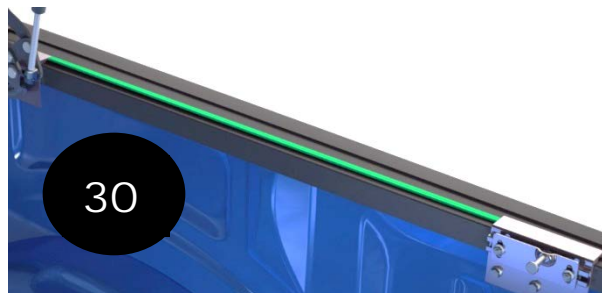

Measure from the rear edge of the front bed rail to locate the rear bed rail position.

Refer to the following chart for the measurement distance for your truck.

Note: For 14+ GM trucks equipped with a drop-in bed liner to may have to relieve the liner locally to provide clearance for the rear back plate nut.

Rear Bed Rail Distance (in) from Front Rail	
07 GM 5.5 Box	22 1/8
07 GM 6.5 Box	31 3/4
14+ GM 5.5 Box	22 1/8
14+ GM 6.5 Box	31 3/4
09 Ford 5.5 Box	19 7/8
09 Ford 6.5 Box	31 1/2
15+ Ford 5.5 Box	19
15+ Ford 6.5 Box	30 7/8
09 RAM 5.5 Box	19 7/8
09 RAM 6.5 Box	28 7/8

Align the Rear Latches

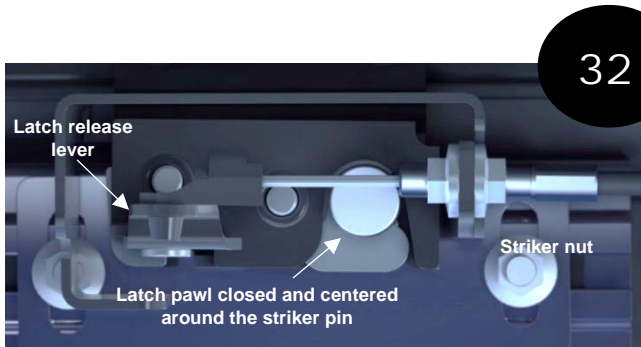

Loosen the two striker nuts holding the striker in the shipping position on the rear bed rails.

Open the rear cover latches by pivoting the release levers.

Carefully lower the rear cover into the closed position. From inside the truck box close the latch pawls around the striker arms on each side.

With an associate holding the cover at the just below the trim height of the front of the rear cover, center the striker within the latch pawl opening and secure the striker bolts.

Misalignment will cause a hard to latch condition.

Repeat the operation for the other side and then open and carefully close the rear cover to ensure that the latches are operating smoothly.

Your Installation is Complete