

ESP Plug O-Ring Change Improving Contamination Resistance

To: All Distributors of STEMCO Wheel End Products

STEMCO is pleased to introduce an important performance enhancement to our ESP Hubcap Plug. This improvement adds a second O-Ring for superior contamination resistance and retention. The new design change is now available for all orders. This enhancement is being treated as a running change, therefore all ESP, and ESP related, STEMCO part numbers will remain as shown in the table below.

Attached is a PDF copy of the updated literature associated with this change.

STEMCO ESP PLUG PART NO.	DESCRIPTION
350-4065	HUB CAP, ESP
350-4075	HUB CAP, ESP
350-4795	HUB CAP, GRAY ESP, GREASE
350-5094	HUB CAP, GREASE (WHITE)
353-4009	HUB CAP, ESP
353-4024	HUB CAP, ESP
353-4065	HUB CAP, ESP
359-6124	SENTINEL ESP BLISTER PACK (2 PLUGS)
359-6137	DAV BLISTER PACK
300-5009	HUB CAP, ESP, 25 PACK W/GASKET
303-5009	HUB CAP, ESP, 25 PACK W/GASKET
350-4009	HUB CAP, ESP
350-4024	HUB CAP, ESP
350-4195	HUB CAP, ESP
350-4809	HUB CAP, ESP, GREASE
350-4895	HUB CAP, CLEAR ESP, GREASE
350-5083	HUB CAP, GREASE
350-5099	HUB CAP, ESP
353-4075	HUB CAP, ESP
353-4195	HUB CAP, ESP
353-5099	HUB CAP, ESP
359-6125	PLUG, HUBCAP, SENTINEL ESP (BULK)

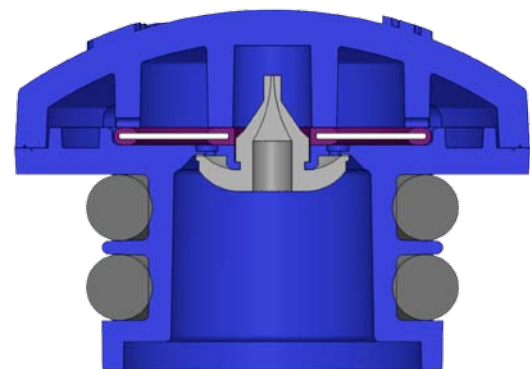

New Version

Improved Design with Second O-ring

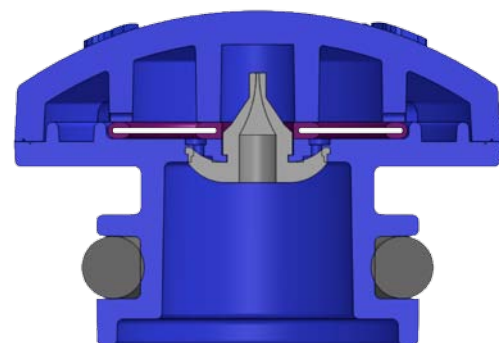

Old Version

Single O-ring

Thank you for your continued support of STEMCO.