

DEFEND YOUR WHEEL END



DEFENDER™

100% Corrosion Free Hub Cap

Stainless Steel Reinforcement Inserts

Protection Against Water and Contamination

Available with Sentinel® Technology

No More Window Leaks

Exceptional chemical bond between the hubcap body and window for strength and no leaks

Superior Sealing Performance

Between hub cap and hub due to offset sealing boss on flange

Longer Life Wheel End

Magnetic plug option pulls abrasive material away from critical components



Defend Your Wheel End

Superior Design

- **Permanent Window Bond**
Ultrasonically welded for maximum contaminant exclusion
- **Sealing Ring**
Added line of defense against contaminants
- **Reinforcement Insert**
Offers structural integrity even under the most grueling conditions
- **Corrosion Free Materials**
Composite materials reinforced with stainless steel inserts make for a durable and long-lasting hubcap that is extremely resistant to impact and corrosion.

Options

- **Window Options**
 - Oil
 - Grease
- **With or Without Side Fill Plug**
- **Designed for Easy Hubbracket Installation**
Integrates seamlessly with other STEMCO Wheel End products like the Hubdometer, DataTrac Pro, and TracBat.
- **Sentinel Technology – Contaminant Resistant Tamper Free**
 - Removable Plugs (Red Plug or ESP)
 - Sentinel Technology

Defender™ Hub Cap Cross Reference

SKF Cross Reference	STEMCO Cross Reference	Defender Part No.	Description	QTY
1612	300-4024	360-4024	Red Rubber Plug "FF"- Bulk	20
1612	340-4024	361-4024	Red Rubber Plug "FF"	1
1612	303-4024	363-4024	Red Rubber Plug - "FF" - w/ side fill - Bulk	20
1612	343-4024	364-4024	Red Rubber Plug - "FF" - w/ fill plug	1
1612	356-4024	366-4024	Sentinel Oil - "FF" w/ magnetic fill plug - Bulk	20
1612	356-4024	367-4024	Sentinel Oil - "FF" w/ magnetic fill plug	1
1612	358-4024	369-4024	Sentinel Grease "FF"	1
1643	300-4009	360-4009	Red Rubber Plug "N"- Bulk	20
1643	340-4009	361-4009	Red Rubber Plug "N"	1
1643	303-4009	363-4009	Red Rubber Plug "N" w/ side fill - Bulk	20
1643	343-4009	363-4009	Red Rubber Plug "N" w/ fill plug	1
1643	356-4009	366-4009	Sentinel Oil - "N" w/ magnetic fill plug - Bulk	20
1643	356-4009	367-4009	Sentinel Oil - "N" w/ magnetic fill plug	1
1643	358-4009	368-4009	Sentinel Grease "N"- Bulk	20
1643	358-4009	369-4009	Sentinel Grease "N"	1
1696	340-4195	360-4195	Red Rubber Plug "P"- Bulk	20
1696	340-4195	361-4195	Red Rubber Plug "P"	1
1696	343-4195	363-4195	Red Rubber Plug "P" w/ side fill - Bulk	20
1696	343-4195	364-4195	Red Rubber Plug "P" w/ fill plug	1
1696	356-4195	366-4195	Sentinel Oil - "P" w/ magnetic fill plug - Bulk	20
1696	356-4195	367-4195	Sentinel Oil - "P" w/ magnetic fill plug	1
1696	358-4195	368-4195	Sentinel Grease "P"- Bulk	20
1696	358-4195	369-4195	Sentinel Grease "P"	1

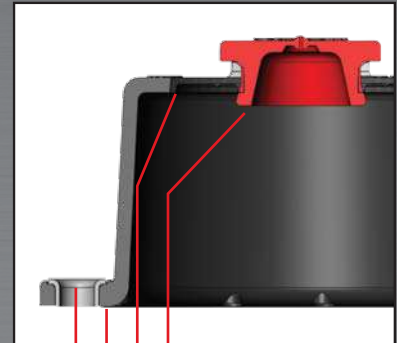

- Vent
- Permanent Bond
- Sealing Ring
- Insert



- Plug
- Vent
- Stainless Inserts





UNCOMPROMISING WHEEL END PROTECTION

Commercial trucking can put enormous demands on wheel end components. Built to withstand the harshest conditions, the STEMCO® Defender™ hub cap is made from an ultra-durable, corrosion-free, composite material and is available with a permanently bonded, leak-proof window.

100% Corrosion-Free Hub Cap

Composite materials with stainless-steel reinforcement inserts will not corrode.

Protection Against Water and Contamination

Available with Sentinel® Technology to reduce contaminant build-up on hub windows, allowing for accurate lube-level readings.

No More Window Leaks

Exceptional chemical bond between the hub cap body and window for strength and no leaks.

Superior Sealing Performance

Offset sealing boss on flange provides extremely durable sealing between hub cap and hub.

Longer-Life Wheel End

Magnetic plug option pulls abrasive material away from critical components.



STEMCO®

A Higher Standard of Performance.™

an EnPro Industries company

Making the Roadways Safer®

DURABLE CONSTRUCTION. INNOVATIVE DESIGN.

BUILT FOR ROADWAY SAFETY AND EQUIPMENT LONGEVITY

Permanent Window Bond

- Ultrasonically welded for maximum contaminant exclusion

Sealing Ring

- Added line of defense against contaminants

Reinforcement Insert

- Offers structural integrity even under the most grueling conditions

Corrosion-Free Materials

- Composite materials reinforced with stainless-steel inserts make for a durable and long-lasting hub cap that is extremely resistant to impact and corrosion.

OPTIONS

Window Options

- Oil
- Grease

With or Without Side Fill Plug

- Plug adds convenience and efficiency for reduced maintenance downtime

Seamless Integration

- Designed for easy Hubodometer® bracket installation.
- Integrates seamlessly with other STEMCO wheel end products like the Hubodometer, DataTrac® Pro, and TracBat®.

Sentinel® Technology

- Contaminant-resistant, tamper-free
- Removable plugs (red plug or ESP)

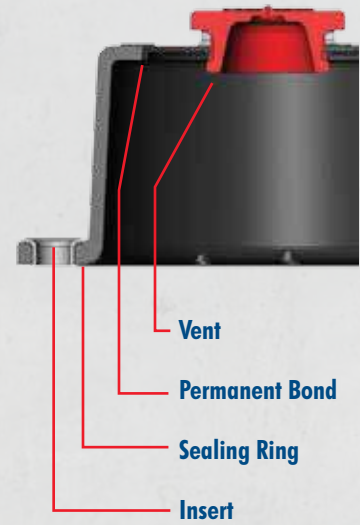

DEFENDER™ HUB CAP CROSS REFERENCE

SKF CROSS REFERENCE	STEMCO CROSS REFERENCE	DEFENDER PART NO.	DESCRIPTION	QUANTITY
1612	300-4024	360-4024	Red Rubber Plug "FF"- Bulk	20
1612	340-4024	361-4024	Red Rubber Plug "FF"	1
1612	303-4024	363-4024	Red Rubber Plug - "FF" - w/ side fill - Bulk	20
1612	343-4024	364-4024	Red Rubber Plug - "FF" - w/ fill plug	1
1612	356-4024	366-4024	Sentinel Oil - "FF" w/ magnetic fill plug - Bulk	20
1612	356-4024	367-4024	Sentinel Oil - "FF" w/ magnetic fill plug	1
1612	358-4024	369-4024	Sentinel Grease "FF"	1
1643	300-4009	360-4009	Red Rubber Plug "N"- Bulk	20
1643	340-4009	361-4009	Red Rubber Plug "N"	1
1643	303-4009	363-4009	Red Rubber Plug "N" w/ side fill - Bulk	20
1643	343-4009	364-4009	Red Rubber Plug "N" w/ fill plug	1
1643	356-4009	366-4009	Sentinel Oil - "N" w/ magnetic fill plug - Bulk	20
1643	356-4009	367-4009	Sentinel Oil - "N" w/ magnetic fill plug	1
1643	358-4009	368-4009	Sentinel Grease "N"- Bulk	20
1643	358-4009	369-4009	Sentinel Grease "N"	1
1696	340-4195	360-4195	Red Rubber Plug "P"- Bulk	20
1696	340-4195	361-4195	Red Rubber Plug "P"	1
1696	343-4195	363-4195	Red Rubber Plug "P" w/ side fill - Bulk	20
1696	343-4195	364-4195	Red Rubber Plug "P" w/ fill plug	1
1696	356-4195	366-4195	Sentinel Oil - "P" w/ magnetic fill plug - Bulk	20
1696	356-4195	367-4195	Sentinel Oil - "P" w/ magnetic fill plug	1
1696	358-4195	368-4195	Sentinel Grease "P"- Bulk	20
1696	358-4195	369-4195	Sentinel Grease "P"	1

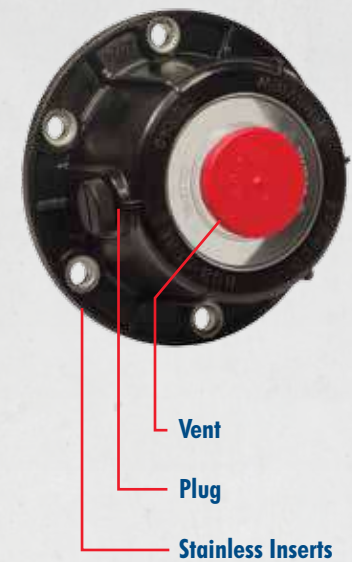

STEMCO, Defender, Sentinel, Hubodometer, DataTrac and TracBat are registered trademarks of STEMCO LP. ©2017 STEMCO LP. Printed in the USA. Part No. 571-3184 | Rev. 5/17

STEMCO
A Higher Standard of Performance.™

an EnPro Industries company



STEMCO HUB CAPS
THE INDUSTRY LEADER, PROVIDING
PROVEN PROTECTION AND EXCEPTIONAL
VALUE FOR EVERY FLEET



STEMCO®

INNOVATIVE DESIGNS AND SUPERIOR MATERIALS ENSURE SAFETY AND DURABILITY

STEMCO® has provided the trucking industry with reliable hub caps for more than 60 years. Throughout our history, we have recognized the need for tougher, long-lasting hub caps that meet the performance, design and price requirements related to selecting the right hub cap for any fleet. To meet that need, STEMCO has engineered a menu of hub cap options designed to meet the varying performance expectations of each fleet, all in an effort to maximize performance and value.

WITH WHEEL END INTEGRITY AND DOWN TIME ON THE LINE, DO NOT ACCEPT LESSER QUALITY IMITATIONS OR KNOCK OFFS. TRUST THE EXPERTS, TRUST STEMCO.

Innovative Product Line

Product- and application-specific technology designed to eliminate contaminants and extend wheel end life.

Superior Materials

Cast aluminum to dissipate heat.

Numerous Lubricant Options

Oil, semi-fluid grease, and hard-pack grease hub caps to meet performance, design and price requirements of today's fleets worldwide.

Broad Application Coverage

Full-line coverage for trailer and tractor applications.

TRADITIONAL HUB CAPS

The traditional aluminum series 340 and 343 provide durability with the trademark red plug to allow venting of the hub cap. Using cast aluminum for constructing the hub cap body prevents warpage and provides superior durability and heat-dissipation properties. The trucking industry recognizes STEMCO hub caps as the benchmark.



343-4024
Steer



343-4046
Steer



343-4065
Steer



343-4095
Steer



343-4249
Steer



346-5110
Steer



340-4119
Drive



340-4975
Trailer



343-4009
Trailer



343-4064
Trailer



343-4075
Trailer



343-4342
Trailer

SENTINEL® HUB CAPS

Sentinel Technology provides an unmatched filtering system to eliminate contamination of lubricant from grime, dirt or water. STEMCO provides four options to put Sentinel Technology to work for you:

- The Sentinel hub cap provides a tamper-proof system for maximum protection and maintenance-free performance.
- Integrated Sentinel hub caps integrate the Sentinel features into the window with fewer components and greater wheel end visibility.
- The Sentinel ESP (Extended Service Plug) and Sentinel ESP Filtered Drive Axle Vent allow economical retrofitting of wheel ends and drive axles with the benefits of STEMCO's exclusive Sentinel Technology.



348-4009
Trailer



356-4009
Trailer



353-4009
Trailer



359-6125
ESP Plug

359-6124
Blister Pack (2/pk)



359-6137
Drive Axle Vent

POPULAR REPLACEMENT PARTS

- **359-5995**
4009 Oil Window Kit
- **359-5990**
Large Red Rubber Plug
- **359-5915**
Small 3/4" Red Rubber Plug

STAMPED STEEL HUB CAPS

STEMCO Stamped Steel grease hub caps are manufactured from 14-gauge steel and have a protective yellow chromate plating with a clear lacquer coating for additional protection from corrosion. For synthetic-base grease, use the vented 340-5096 version cap. For petroleum-base grease, use the non-vented 340-5097 cap.



340-0044
Steer



340-5096
Trailer



340-5097
Trailer

GREASE HUB CAPS

For grease applications, the 342 series Dirt Exclusion hub caps provide the same 340 casting without a side fill plug, plus a solid window with a sintered metal vent for venting purposes. To further support grease wheel ends, STEMCO developed the 352 series Solid Aluminum hub caps with a duckbill vent inserted in the face of a solid hub cap.



352-4009
Trailer



342-4009
Trailer

INFLATION HUB CAPS

STEMCO tire inflation hub caps are available in both oil and grease for several popular applications. The oil hub caps have a side fill plug and a standard window with oil fill lines. The grease hub caps do not have a side fill plug and incorporate a gray opaque window with no markings.



343-4370
PSI™



831-0212
Aeris®

DEFENDER™ HUB CAPS

The Defender hub cap is 100% corrosion-free, with stainless steel reinforcement inserts. It achieves longer wheel-end life using a magnetic plug that pulls abrasive material away from critical components. An exception chemical bond between the hub cap and window ensures a strong seal and no leaks.



368-4195
Trailer

363-4009
Trailer

366-4024
Steer

HUBODOMETER® HUB CAPS

STEMCO Hubodometer hub caps provide ease and convenience when installing our mechanical or electronic DataTrac® Hubodometers. The 347 series aluminum hub cap is mounted with a hub window while the 640 series is a full grilamid Hubodometer hub cap with a metallic flange. Both allow for mounting of the Hubodometer directly through the center of the hub cap.



347-4009
Trailer



640-0001
Trailer

POPULAR HUB CAP OPTIONS WITH BOLT SPECIFICATIONS

Stemco Base Part Number	Standard Hub Cap, No Side Fill	Defender™ Hub Cap	Dirt Exclusion, Grease	Standard Hub Cap, Side Fill	Defender™ Hub Cap	Standard Hub Cap, Hub Window	Sentinel® Hub Cap	Sentinel® Hub Cap Grease	Solid Aluminum Grease / Vented	Integrated Sentinel® Oil	Defender™ Hub Cap	Integrated Sentinel® Grease	Defender™ Hub Cap	Bolt Circle	Bolt Size	Number of Bolts
	340	360	342	343	363	347	348	349	352	356	366	358	368			
4009	X	X	X	X	X	X	X	X	X	X	X	X	X	5-1/2	5/16	6
4013	X		X	X	X	X	X	X		X		X		5-1/2	5/16	5
4024	X	X	X	X	X					X	X	X		4-1/2	5/16	6
4046	X			X			X	X		X		X		5-1/2	5/16	6
4075	X		X	X		X	X	X		X		X		6-1/4 x 8 UN(M)		
4095	X		X	X			X	X	X	X		X		5-1/2	5/16	6
4195	X	X	X	X	X	X	X	X	X	X	X	X	X	6-3/4	5/16	6
4249	X		X	X										5-1/2	5/16	6
4281							X	X						5-17/32	3/8	6
4370*	X			X										5-1/2	5/16	6
4371*	X			X										6-1/4 x 8 UN(M)		
4372*	X			X										6-3/4	5/16	6

*PSI

LEGEND

- 340/360 - No Pipe Plug
- 342 - Dirt Exclusion Grease
- 343/363 - With Pipe Plug
- 348 - Sentinel® Oil
- 349 - Sentinel® Grease
- 350 - With ESP Sentinel® Plug
- 353 - With ESP Sentinel® Plug
- 356/366 - Sentinel® Oil - Integrated
- 358/368 - Sentinel® Grease Integrated
- 349 - Sentinel® Grease
- 4009 - Tapered Spindle "TN"
- 4195 - Parallel Spindle "TP"

HUB CAP CROSSOVER

WHEEL END

COMPETITIVE PART NO.	COMPETITOR'S NAME	STEMCO PART NO.
1282	SKF	340-4975
1612	SKF	343-4024
1612	SKF	360-4024
1612	SKF	361-4024
1612	SKF	363-4024
1612	SKF	364-4024
1612	SKF	366-4024
1612	SKF	367-4024
1612	SKF	369-4024
1623	SKF	343-4066
1627	SKF	343-4019
1642	SKF	343-4013
1643	SKF	343-4009
1643	SKF	360-4009
1643	SKF	361-4009
1643	SKF	363-4009
1643	SKF	364-4009
1643	SKF	366-4009
1643	SKF	367-4009
1643	SKF	368-4009
1643	SKF	369-4009
1665	SKF	343-4042
1681	SKF	343-4186
1682	SKF	343-4075
1696	SKF	343-4195
1696	SKF	360-4195
1696	SKF	361-4195
1696	SKF	363-4195
1696	SKF	364-4195
1696	SKF	366-4195
1696	SKF	367-4195
1696	SKF	368-4195
1696	SKF	369-4195
1703	SKF	343-4249
1711	SKF	343-4024
1723	SKF	343-4066
1727	SKF	343-4019
1742	SKF	343-4013
1743	SKF	343-4009
1743	SKF	343-4046
1743	SKF	343-4095
1753	SKF	343-4249
1765	SKF	343-4042
1770	SKF	343-4034
1781	SKF	343-4186
1788	SKF	343-4249
1800	SKF	347-4009

COMPETITIVE PART NO.	COMPETITOR'S NAME	STEMCO PART NO.
1801	SKF	347-4013
1811	SKF	343-4024
1823	SKF	343-4042
1742	SKF	343-4013
1843	SKF	343-4009
1843	SKF	343-4046
1843	SKF	343-4095
1865	SKF	343-4066
1870	SKF	343-4034
1890	SKF	343-4249
340-009	National	340-4009
340-009BK	National	300-4009
340-975	National	340-4975
340-975BK	National	340-4975
343-009	National	343-4009
343-009BK	National	303-4009
401911P	Mechanex/Barrier	340-4975
506085	Eaton	343-4024
506089	Eaton	343-4249
64002	TriSeal	343-4019
64009	TriSeal	343-4009
64009H	TriSeal	347-4009
64013	TriSeal	343-4013
64024	TriSeal	343-4024
64029	TriSeal	343-4186
64034	TriSeal	343-4034
64042	TriSeal	343-4024
64046	TriSeal	343-4046
64046	TriSeal	343-4095
64046	TriSeal	343-4249
64066	TriSeal	343-4066
64075A	TriSeal	343-4075
64075G	TriSeal	342-4075
64075P	SKF	340-4975
64249	SKF	343-4249
812928	SKF	343-4095
815214	SKF	343-4195
821338	SKF	343-4009
821907	SKF	343-4009
C40-4009	SKF	340-4009
C40-4009BP	SKF	300-4009
C40-4975	SKF	340-4975
C40-4975BP	SKF	340-4975
C40-5097BP	SKF	340-5097
C43-4009	SKF	343-4009
C43-4009BP	SKF	303-4009
C43-4013	SKF	343-4013
C43-4024	SKF	343-4024

COMPETITIVE PART NO.	COMPETITOR'S NAME	STEMCO PART NO.
C43-4042	SKF	343-4042
C43-4075	SKF	343-4075
C43-4095	SKF	343-4095
C43-4098	SKF	343-4098
C43-4249	SKF	343-4249
DG-5/6P	Dual Dynamics	340-4013
DG-5/6PS	Dual Dynamics	343-4013
DG-6F	Dual Dynamics	340-4046
DG-6F4.5	Dual Dynamics	340-4024
DG-6F4.5P	Dual Dynamics	343-4013
DG-6F4.5PC	Dual Dynamics	343-4024
DG-6F4.5S	Dual Dynamics	347-4075
DG-6FL	Dual Dynamics	340-4249
DG-6FP	Dual Dynamics	347-4009
DG-6FPC	Dual Dynamics	340-4024
DG-6P	Dual Dynamics	340-4009
DG-6PS	Dual Dynamics	343-4009
DG-6PSC	Dual Dynamics	340-4046
DG-7.5P	Dual Dynamics	340-4195
DG-7.5PS	Dual Dynamics	343-4195
DG-P	Dual Dynamics	340-4075
DG-PS	Dual Dynamics	343-4075
DG-PSC	Dual Dynamics	343-4249
H075	National	343-4075
HS1643	Mechanex/Barrier	343-4249
HU009A	National	343-4009
HU009A	National	343-4046
HU013A	National	343-4013
HU019A	National	343-4019
HU024A	National	343-4024
HU028A	National	343-4186
HU034A	National	343-4034
HU042A	National	343-4042
HU066A	National	343-4066
HU110A	National	343-4095
HU110A	National	343-4249
P411601	Mechanex/Barrier	343-4009
P411605	Mechanex/Barrier	343-4095
P411605	Mechanex/Barrier	343-4249
P411608	Mechanex/Barrier	343-4013
P411620	Mechanex/Barrier	343-4066
P411622	Mechanex/Barrier	343-4042
P411629	Mechanex/Barrier	343-4186
P411630	Mechanex/Barrier	343-4024
P411640	Mechanex/Barrier	343-4034
P411655	Mechanex/Barrier	343-4075
P411688	Mechanex/Barrier	343-4095
P411967	Mechanex/Barrier	343-4046

HUB CAP TORQUE SPECS

THREADED HUB CAPS		HUB CAP MOUNTING BOLTS				HUB CAP COMPONENTS		
XXX-4075	100 ft/lbs	1/4"	8-12 ft/lbs	5/8"	22-26 ft/lbs	359-6032	#8 Torx Screw	18-23 in/lbs
340-4975	50-60 ft/lbs	5/16"	12-16 ft/lbs	3/4"	24-28 ft/lbs	359-5984	3/8" Mag Plug	5-9 ft/lbs
340-4976	50-60 ft/lbs	3/8"	16-20 ft/lbs	7/8"	26-30 ft/lbs	359-5985	3/8" Pipe Plug	5-9 ft/lbs
640-0003	50-60 ft/lbs	7/16"	18-22 ft/lbs	6MM	8-12 ft/lbs			
		1/2"	20-24 ft/lbs	8.5MM	12-16 ft/lbs			

STEMCO, Aeris, DataTrac, Defender, Hubdrometer, PSI and Sentinel are trademarks of STEMCO LP.
 ©2017 STEMCO LP. Printed in the USA.
 Part No. 571-3185 | Rev. 10/17



an EnPro Industries company