

INSTALLATION INSTRUCTIONS

RATTLER STEEL RUNNING BOARDS

09-15 DODGE RAM 1500 QUAD CAB

PARTS LIST:

2	Steel Running Boards	5	12mm Lock Washers
1	Driver/Left Front Mounting Bracket	5	12mm Hex Nuts
1	Driver/Left Center Mounting Bracket	6	10-1.5mm x 35mm Hex Bolts
2	Driver/Left Front and Center Support Brackets	6	10mm x 27mm OD x 3mm Flat Washers
1	Driver/Left Rear Mounting Bracket	6	10mm Lock Washers
1	Driver/Left Rear Long Support Bracket	6	8-1.25mm x 30mm Hex Bolt
2	Passenger/Right Front and Center Mounting Brackets	12	8-1.25mm x 25mm Hex Bolt
2	Passenger/Right Front and Center Support Brackets	30	8mm x 24mm x 2mm Flat Washer
1	Passenger/Right Rear Mounting Bracket	6	8mm Lock Washers
1	Passenger/Right Long Rear Support Bracket	12	8-1.25mm Nylon Lock Nuts
6	12mm x 35mm Bolt x 10mm Nut Plates	6	6mm Double Bolt Plates
6	12mm Plastic Retainers	12	6mm x 22mm OD x 2mm Flat Washers
5	12mm x 32mm OD x 3mm Flat Washers	12	6mm Lock Washers
		12	6mm Hex Nuts

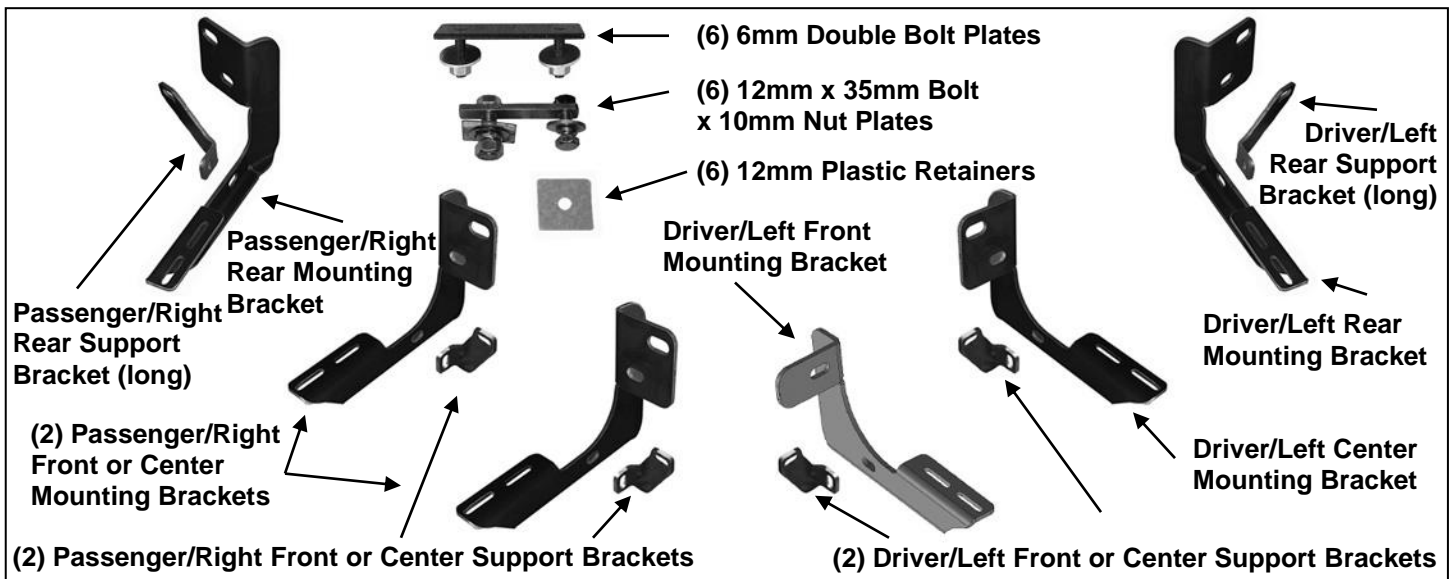

PROCEDURE:

REMOVE CONTENTS FROM BOX. VERIFY ALL PARTS ARE PRESENT. READ INSTRUCTIONS CAREFULLY BEFORE STARTING INSTALLATION. DRILLING IS REQUIRED ON 2009-12 MODELS.

- Starting at the driver side-front of the vehicle, remove the sealing tape covering the factory holes on the side of the inner panel, **(Figure 1)**.
- Determine the correct procedure to attach the driver side front Bracket for your model/year:

Models without factory threaded inserts in body panel (Figures 1 & 3):

- Partially thread a 12mm Plastic Retainer onto the threaded end of a 12mm Bolt and Nut Plate, **(Figure 2)**. Insert the Bolt and Nut Plate into the oval hole and tighten the Plastic Retainer, **(Figure 3)**. **NOTE:** The Plastic Retainer is designed to keep the Bolt/Nut Plate from falling into the body panel and to aid in Bracket installation.
- Select the driver side front Mounting Bracket, **(Figure 5)**. Rotate the 12mm Bolt and Nut plate until the threaded nut lines up with the hole in the Mounting Bracket and body, **(Figure 3)**. Attach the Bracket to the threaded Nut Plate with (1) 10mm x 35mm Hex Bolt, (1) 10mm Lock Washer and (1) 10mm Flat Washer, **(Figures 5 & 7)**. Do not fully tighten hardware at this time.

Models with factory threaded inserts:

- Attach the driver side Front Bracket to the threaded insert with (1) 8mm x 30mm Hex Bolt, (1) 8mm Lock Washer and (1) 8mm Flat Washer, **(Figures 4, 5 & 7)**. Leave hardware loose.

3. Next, select the driver side front Support Bracket, (**Figures 5 & 6**). Attach the Bracket to the front of the front Bracket with (1) 8mm x 25mm Hex Bolt, (2) 8mm Flat Washers and (1) 8mm Nylon Lock Nut, (**Figures 5 & 7**). Rotate the Support Bracket to the back of the pinch weld. Line up the slot in the top of the Support Bracket with the factory holes in the pinch weld. Attach the Bracket to the pinch weld with (1) 8mm x 25mm Hex Bolt, (2) 8mm Flat Washers and (1) 8mm Nylon Lock Nut, (**Figures 6—8**). Do not fully tighten hardware at this time. **IMPORTANT: 2009-12** models are not equipped with factory holes and will require drilling through the pinch weld to attach the Support Bracket, (**Figure 7**). Do not drill through pinch weld at this time, (**see Step 10**).
4. Move along the side of the body panel to the center mounting location, (**Figure 9**). Select (1) 12mm Bolt/Nut Plate. Repeat **Step 2** to install the Bolt/Nut Plate. Select the driver side center Bracket (**Figure 10**). Attach the Bracket to the Bolt/Nut Plate with (1) 12mm Flat Washer, (1) 12mm Lock Washer and (1) 12mm Hex Nut, (**Figure 11**). Line up the remaining hole in the Bracket with the hole in the inner body panel. Rotate the Bolt and Nut Plate until the Nut lines up with the hole in the Bracket. Attach the Bracket to the Bolt/nut Plate with (1) 10mm x 35mm Hex Bolt, (1) 10mm Lock Washer and (1) 10mm Flat Washer, (**Figure 11**). Do not fully tighten hardware at this time.
 - a. **IMPORTANT NOTE:** Models with threaded insert, attach the Bracket to the threaded insert with (1) 8mm x 30mm Hex Bolt, (1) 8mm Lock Washer and (1) 8mm Flat Washer. The 10mm hardware will not be required (**Step 2**). Snug but do not tighten hardware.
5. Repeat **Step 3** to install the center Support Bracket, (**Figures 6 & 14**).
6. Move to the rear location, (**Figure 12**). Repeat **Steps 4 & 5** to install the rear Mounting Bracket and Support Bracket, (**Figure 13**). **VERY IMPORTANT:** The rear Brackets, (**Figure 10**), are unique from the front and center brackets, (see **Page 1 & Fig 10**-note mounting plate and angle of rear bracket).
7. Once all (3) Brackets have been installed, select (1) Running Board. Place the Running Board on top of the Brackets. Locate the channels in the bottom of the Running Board. Select (3) 6mm Double Bolt Plates, (**Figure 14**). Insert the Bolt Plates into the channels in the bottom of the Running Board closest to the Brackets. Lift the Running Board up and guide the studs through the Brackets.
8. Attach the Running Board to the Brackets with (6) 6mm Flat Washers, (6) 6mm Lock Washers and (6) 6mm Hex Nuts, (**Figure 15**). **NOTE:** The Running Board is designed to fit close to the vehicle. It may be necessary to loosen the Bracket hardware and tilt the Brackets downward to insert the Running Board between the Brackets and the body. Do not tighten hardware at this time.
9. Properly level and adjust the Running Board and fully tighten all hardware.
 - 2009-12 models requiring drilling for Support Brackets:**
 - a. Make sure the Running Board is level to the vehicle. Line up the slot on the Support Bracket with the back of the pinch weld. Mark the location of the slot onto the pinch weld, (**Figure 7**).
 - b. Drill a 5/16" hole through the pinch weld. **IMPORTANT:** Do not drill too close to the bottom edge of the pinch weld. Drill the hole toward the center of the marked slot.
 - c. Attach each Support Bracket to the back of the pinch weld with (1) 8mm Hex Bolt, (2) 8mm Flat Washers and (1) 8mm Nylon Lock Nut, (**Figures 8, 11 & 13**). Repeat for all Support Brackets. Check for level then fully tighten all hardware.
10. Move to the passenger side of the vehicle. Remove tape covering front, center and rear locations. Repeat **Steps 4—9** for passenger side installation, (**Figures 16—18**). **NOTE:** Refer to **Figure 16** to identify the correct Mounting Bracket for each of the remaining locations. **IMPORTANT:** Passenger side front and center Brackets are identical.
11. Fully tighten all hardware once installation is complete.
12. Do periodic inspections to the installation to make sure that all hardware is secure and tight.

To protect your investment, wax this product after installing. Regular waxing is recommended to add a protective layer over the finish. Do not use any type of polish or wax that may contain abrasives that could damage the finish.

For stainless steel: Aluminum polish may be used to polish small scratches and scuffs on the finish. Mild soap may be used also to clean the Running Board.

For gloss black finishes: Mild soap may be used to clean the Running Board.

Driver Side Installation Pictured

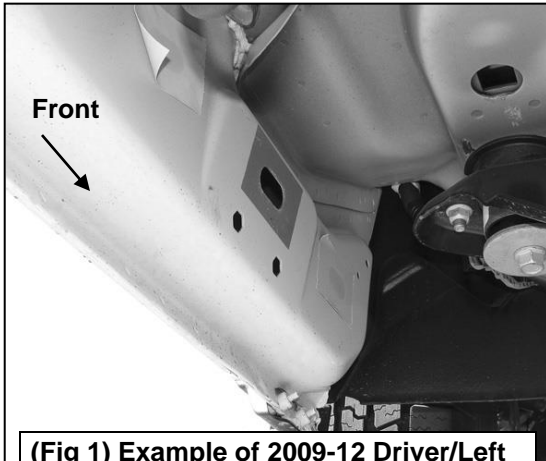

(Fig 1) Example of 2009-12 Driver/Left front mounting location

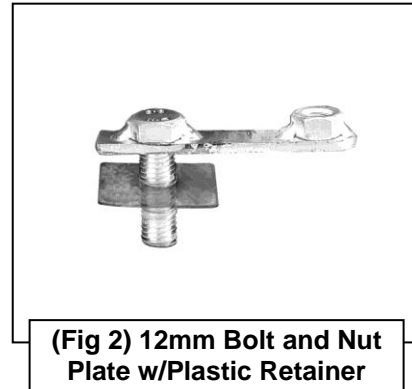

(Fig 2) 12mm Bolt and Nut Plate w/Plastic Retainer

Rotate Bolt/Nut Plate to line up correct threaded hole with body panel and hole in Mounting Bracket (see arrow)

12mm x 35mm Bolt/10mm Nut Plate
12mm Plastic Retainer

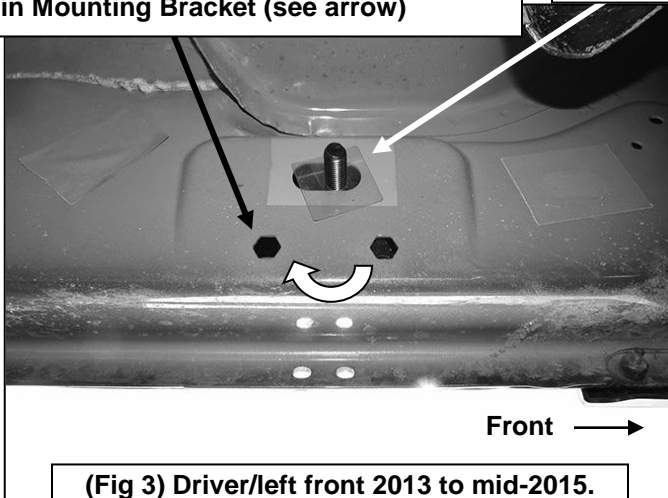

(Fig 3) Driver/left front 2013 to mid-2015.
NOTE: no threaded insert in body panel

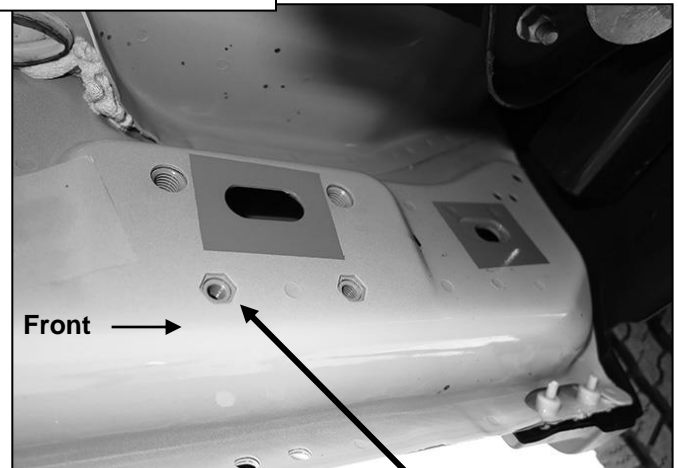

(Fig 4) Driver side front mid 2015-on example of all models with factory installed threaded inserts

Models without threaded insert using Bolt/Nut Plate, use:
10mm x 35mm Hex Bolt
10mm Lock Washer
10mm Flat Washer

Models with threaded insert use:
8mm x 30mm Hex Bolt
8mm Lock Washer
8mm Flat Washer

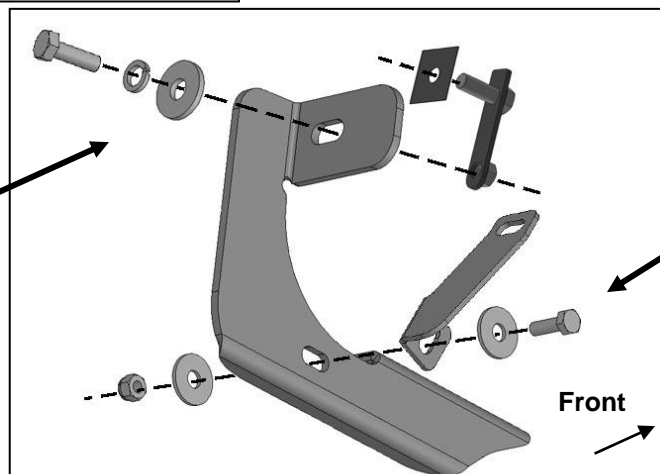

8mm x 25mm Hex Bolt
(2) 8mm Flat Washers
8mm Nylon Lock Nut

(Fig 5) Driver/Left front Mounting Bracket assembly

Driver Side Installation Pictured

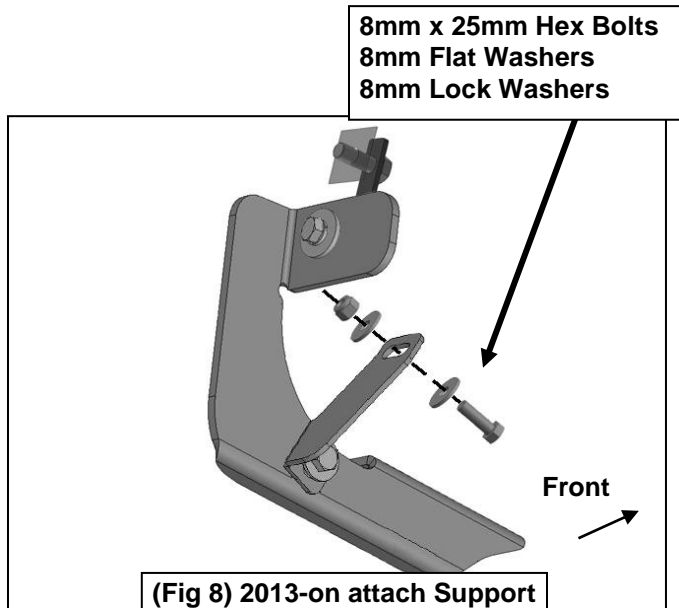
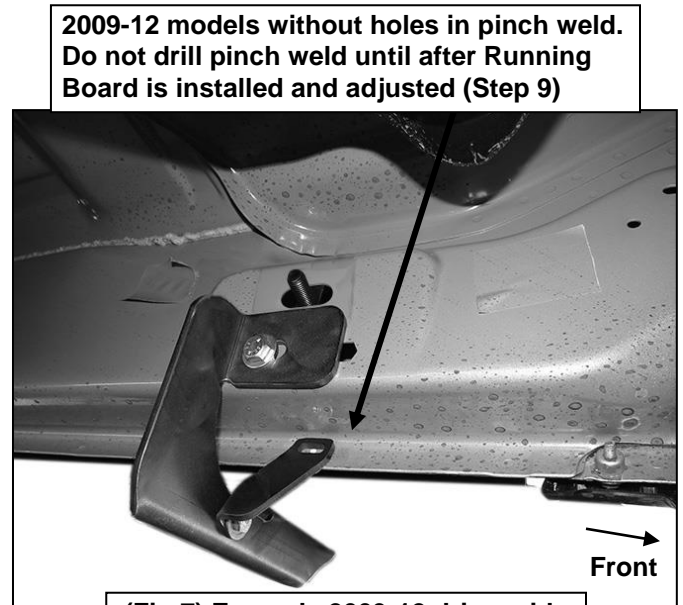
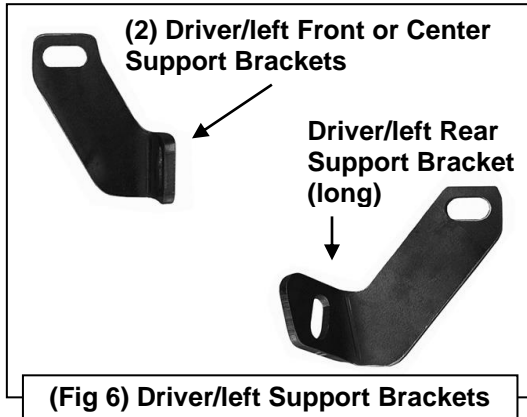

2009-12 models only: Do not mark or drill holes for Support Brackets until after Running Board has been installed, properly adjusted and Mounting Bracket to Bolt Plate hardware fully tightened.

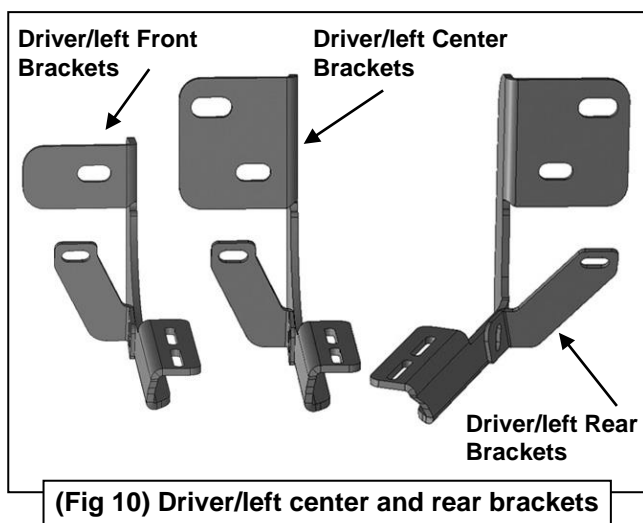
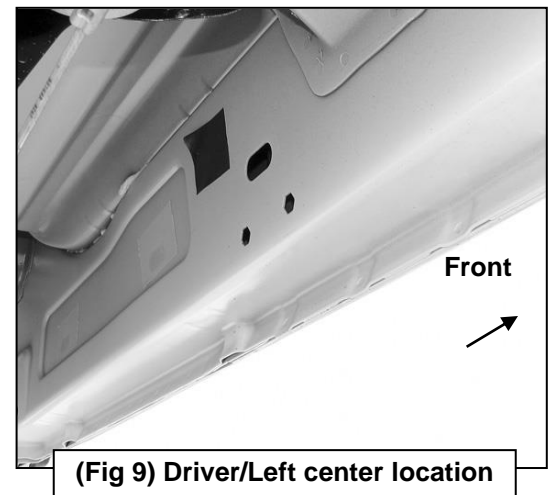

Driver Side Installation Pictured

12mm Flat Washer
12mm Lock Washer
12mm Hex Nut

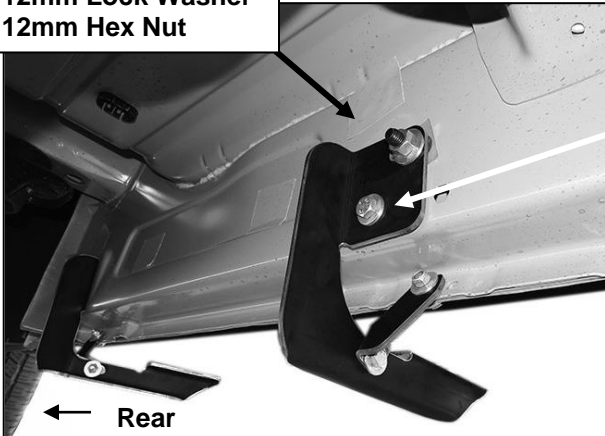

Models without threaded insert using Bolt/Nut Plate, use:
10mm x 35mm Hex Bolt
10mm Lock Washer
10mm Flat Washer

Models with threaded insert use:
8mm x 30mm Hex Bolt
8mm Lock Washer
8mm Flat Washer

(Fig 11) 2013-15 Driver/Left center Bracket installed



(Fig 12) Driver/Left rear location

Models without threaded insert using Bolt/Nut Plate, use:
10mm x 35mm Hex Bolt
10mm Lock Washer
10mm Flat Washer

Models with threaded insert use:
8mm x 30mm Hex Bolt
8mm Lock Washer
8mm Flat Washer

12mm Flat Washer
12mm Lock Washer
12mm Hex Nut

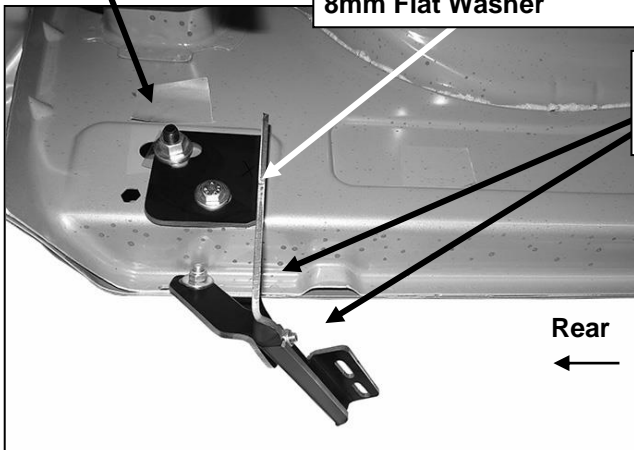

8mm x 25mm Hex Bolt
(2) 8mm Flat Washers
8mm Nylon Lock Nut

(Fig 13) Driver/Left rear bracket installation 2013-on

2009-12 models only: Do not mark or drill holes until after Running Board has been installed, properly adjusted and Mounting Bracket to Bolt Plate hardware fully tightened.

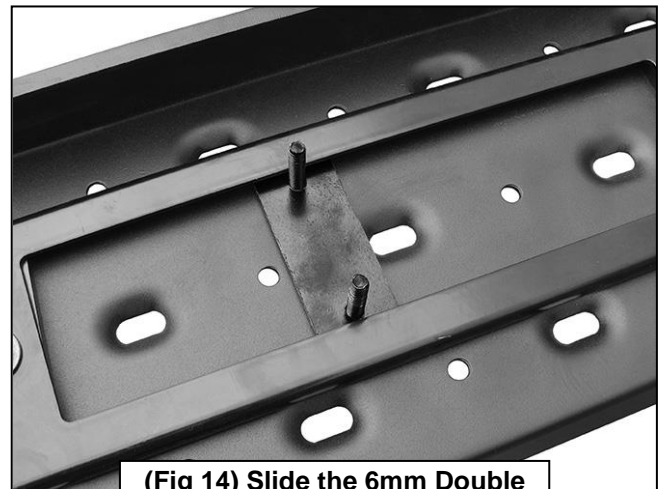

(Fig 14) Slide the 6mm Double Bolt Plate into channels

- (2) 6mm Flat Washers
- (2) 6mm Lock Washers
- (2) 6mm Hex Nuts



2009-12 models only: Do not mark or drill holes until after Running Board has been installed, properly adjusted and Mounting Bracket to Bolt Plate hardware fully tightened.

- 8mm x 25mm Hex Bolts
- (2) 8mm Flat Washers
- 8mm Lock Washers

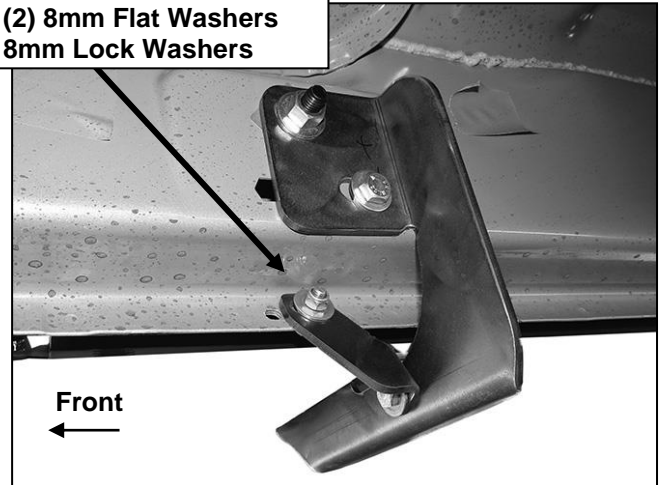

(Fig 16) Passenger/right Front Bracket installed (2013-on with factory holes pictured without Running Board for instruction purposes only)

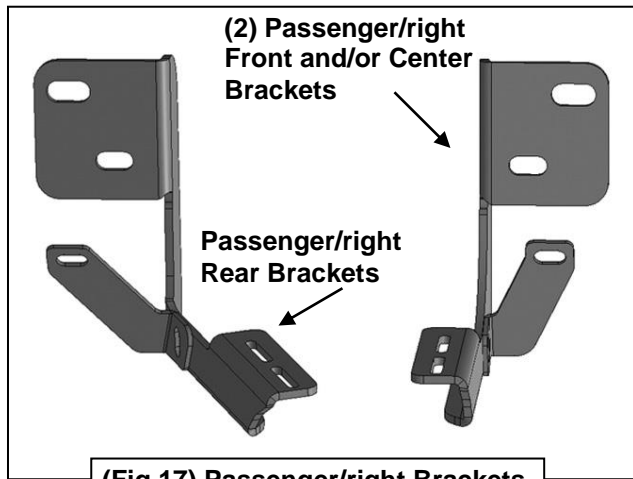

- 8mm x 25mm Hex Bolts
- (2) 8mm Flat Washers
- 8mm Lock Washers

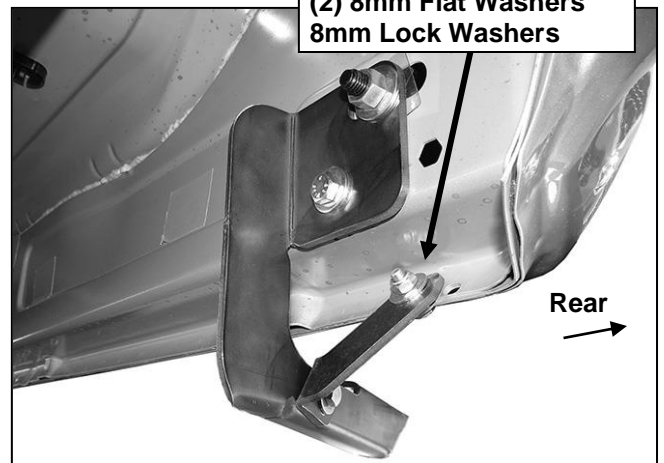

(Fig 18) Passenger/right rear Bracket installed (2013-on with factory holes pictured without Running Board for instruction purposes only)

