

PARTS LIST:

Qty	Description	Qty	Description
1	Driver/Left Sidebar	4	10-1.5mm x 35mm Hex Bolts
1	Passenger/Right Sidebar	4	10mm x 27mm OD x 3mm Flat Washers
1	Driver/Left Front Mounting Bracket	4	10mm Lock Washers
1	Driver/Left Front Support Bracket	5	8-1.25 x 30mm Hex Bolts
1	Passenger/Right Front Mounting Bracket	8	8-1.25 x 25mm Hex Bolts
1	Driver/Left Rear Mounting Bracket	14	8mm x 24mm x 2mm Flat Washers
1	Passenger/Right Rear Mounting Bracket	12	8mm Lock Washers
4	12mm Plastic Retainers	1	8mm Nylon Lock Nut
4	12mm x 35mm Bolt x 10mm Nut Plates	4	6mm x 22mm x 2mm Flat Washers
3	12mm x 32mm OD x 3mm Flat Washers	2	6mm x 25mm Hex Bolts
3	12mm Lock Washers	2	6mm Nylon Lock Nuts
3	12mm Hex Nuts		

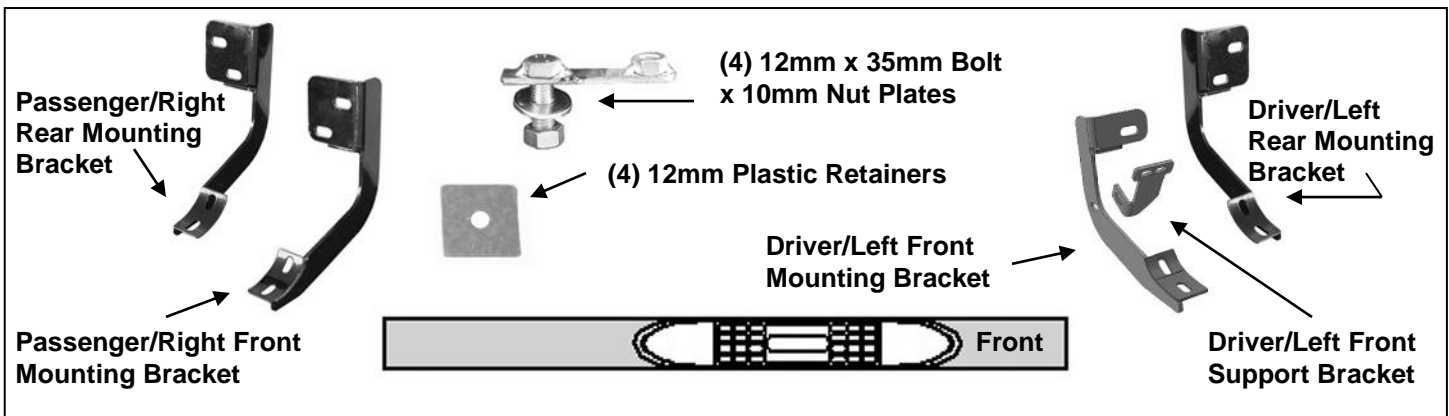

PROCEDURE:

1. REMOVE CONTENTS FROM BOX. VERIFY ALL PARTS ARE PRESENT. READ INSTRUCTIONS CAREFULLY BEFORE STARTING INSTALLATION. ON 2009-10 MODELS, DRILLING IS REQUIRED.
2. Starting at the driver side-front of the vehicle, remove the sealing tape covering the factory holes on the side of the inner panel, **(Figure 1 & 4)**.
3. Determine the correct procedure to attach the driver side front Bracket for your model/year:

Models without factory threaded inserts in body panel:

 - a. Partially thread a 12mm Plastic Retainer onto the threaded end of a 12mm Bolt and Nut Plate, **(Figure 2)**. Insert the Bolt and Nut Plate into the oval hole and tighten the Plastic Retainer, **(Figure 3)**. **NOTE:** The Plastic Retainer is designed to keep the Bolt/Nut Plate from falling into the body panel and to aid in Bracket installation.
 - b. Select the driver side front Mounting Bracket, **(Figure 5)**. Rotate the 12mm Bolt and Nut plate until the threaded nut lines up with the hole in the Mounting Bracket and body, **(Figure 3)**. Attach the Bracket to the threaded Nut Plate with (1) 10mm x 35mm Hex Bolt, (1) 10mm Lock Washer and (1) 10mm Flat Washer, **(Figures 5 & 7)**. Do not fully tighten hardware at this time.

Models with factory threaded inserts:

 - a. Attach the driver side Front Bracket to the threaded insert with (1) 8mm x 30mm Hex Bolt, (1) 8mm Lock Washer and (1) 8mm Flat Washer, **(Figures 4, 5 & 7)**. Leave hardware loose.
4. Next, select the driver side front Support Bracket. Attach the Bracket to the back of the front Bracket with (1) 8mm x 30mm Hex Bolt, (2) 8mm Flat Washers and (1) 8mm Nylon Lock Nut, **(Figures 5 & 7)**. Rotate the Support Bracket to the back of the pinch weld. Line up the slot in the top of the Support Bracket with the (2) factory holes in the pinch weld. Attach the Bracket to the pinch weld with (2) 6mm Hex Bolts, (4) 6mm Flat Washers and (2) 6mm Nylon Lock Nuts, **(Figures 6 & 7)**. Do not fully tighten hardware at this time. **IMPORTANT:** 2009-10 models are not equipped with factory holes and will

5" OVAL STRAIGHT SIDEBARS
09-15 DODGE RAM 1500 REGULAR CAB
10-15 DODGE RAM 25-3500 REGULAR CAB

require drilling through the pinch weld to attach the Support Bracket. Do not drill through pinch weld at this time, (see Step 7).

5. Move along the cab to the rear mounting location, (Figure 8). Select (1) 12mm Bolt/Nut Plate. Repeat Step 3 to install the Bolt/Nut Plate. Select the driver side rear Bracket. Attach the Bracket to the Bolt/Nut Plate with (1) 12mm Flat Washer, (1) 12mm Lock Washer and (1) 12mm Hex Nut, (Figure 9). Do not tighten hardware at this time. Line up the remaining hole in the Bracket with the hole in the inner body panel. Rotate the Bolt and Nut Plate until the threaded end (Nut) lines up with the hole in the Bracket. Secure with (1) 10mm x 35mm Hex Bolt, (1) 10mm Lock Washer and (1) 10mm Flat Washer, (Figure 9).
 - a. **IMPORTANT NOTE:** Models with threaded insert, attach the Bracket to the threaded insert with (1) 8mm x 30mm Hex Bolt, (1) 8mm Lock Washer and (1) 8mm Flat Washer. The 10mm hardware will not be required (Step 5). Snug but do not tighten hardware.
6. Once the front and rear brackets have been installed, carefully position the driver Sidebar onto the Mounting Brackets. Attach the Sidebar to the cradles on the Mounting Brackets using the included (4) 8mm x 25mm Hex Bolts, (4) 8mm Lock Washers and (4) 8mm Flat Washers, (Figures 10 & 11). Do not tighten hardware at this time.
7. Properly level and adjust the Sidebar and fully tighten all hardware.
 - 2009-10 models requiring drilling for driver side front Support Bracket:**
 - a. Make sure the Sidebar is level to the vehicle. Line up the slot on the Support Bracket with the back of the pinch weld. Mark the location of the slot onto the pinch weld.
 - b. Drill (2) 1/4" holes through the pinch weld. **IMPORTANT:** Do not drill too close to the bottom edge of the pinch weld. Drill the holes toward the outside of the marked slot.
 - c. Attach the Support Bracket to the pinch weld with (2) 6mm Hex Bolts, (4) 6mm Flat Washers and (2) 6mm Nylon Lock Nuts. Check for level then fully tighten all hardware.
8. Move to the passenger side of the vehicle. Remove tape covering front and rear locations. Repeat Steps 5—7 for passenger side Mounting Bracket installation, (Figure 11). **NOTE:** Refer to the illustration on Page 1 to identify the correct Mounting Bracket for each of the remaining locations.
9. Do periodic inspections to the installation to make sure that all hardware is secure and tight.

To protect your investment, wax this product after installing. Regular waxing is recommended to add a protective layer over the finish. Do not use any type of polish or wax that may contain abrasives that could damage the finish.

For stainless steel: Aluminum polish may be used to polish small scratches and scuffs on the finish. Mild soap may be used also to clean the Sidebar.

For gloss black finishes: Mild soap may be used to clean the Sidebar.

Driver Side Installation Pictured

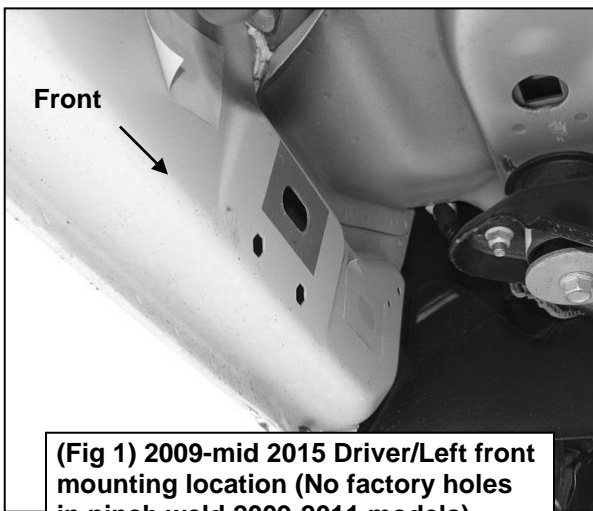

(Fig 1) 2009-mid 2015 Driver/Left front mounting location (No factory holes in pinch weld 2009-2011 models)



(Fig 2) 12mm Bolt-10mm Nut Plate w-Retainer, NOTE: 10mm hardware not required on models with threaded inserts

**5" OVAL STRAIGHT SIDEBARS
09-15 DODGE RAM 1500 REGULAR CAB
10-15 DODGE RAM 25-3500 REGULAR CAB**

**12mm x 40mm Bolt/10mm Nut Plate
12mm Plastic Retainer**

Rotate Bolt/Nut Plate to line up correct threaded hole with body panel and hole in Mounting Bracket (see arrow)

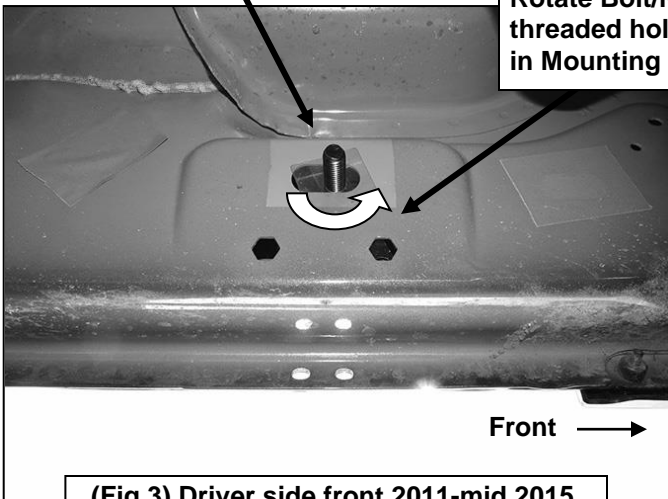

**(Fig 3) Driver side front 2011-mid 2015.
NOTE no threaded insert in body panel**

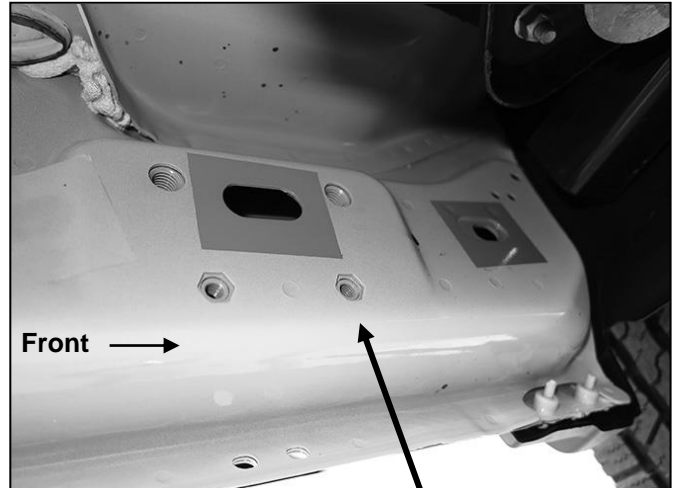

(Fig 4) Driver side front mid 2015-on and example of all models with factory installed threaded inserts

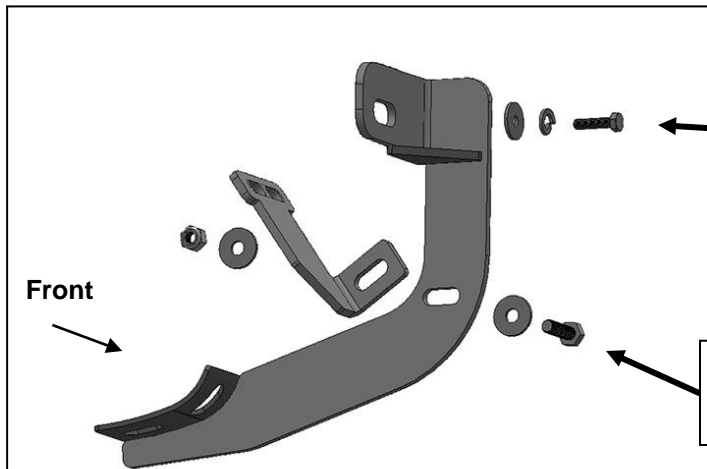

**Models without threaded insert using Bolt/Nut Plate, use:
10mm x 35mm Hex Bolt
10mm Lock Washer
10mm Flat Washer**

**Models with threaded insert use:
8mm x 30mm Hex Bolt
8mm Lock Washer
8mm Flat Washer**

**8mm x 30mm Hex Bolt
(2) 8mm Flat Washers
8mm Nylon Lock Nut**

(Fig 5) Driver/Left front Mounting Bracket assembly

**5" OVAL STRAIGHT SIDEBARS
09-15 DODGE RAM 1500 REGULAR CAB
10-15 DODGE RAM 25-3500 REGULAR CAB**

- (2) 6mm Hex Bolt
- (4) 6mm Flat Washers
- (2) 6mm Nylon Lock Nut

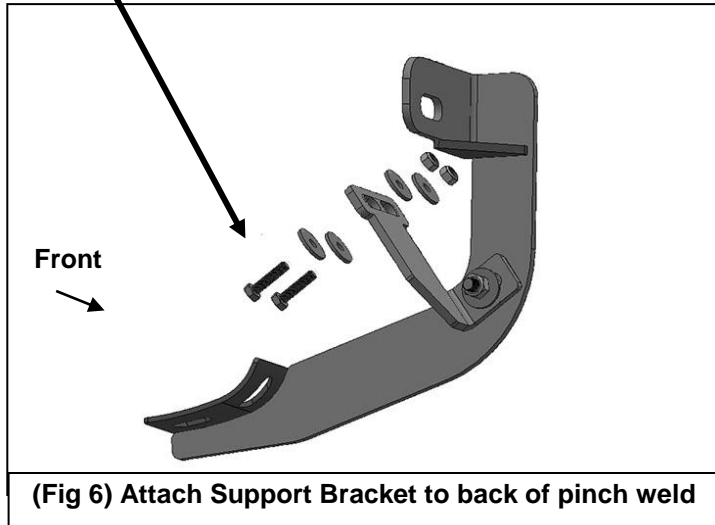

Models without threaded insert using Bolt/Nut Plate, use:
10mm x 35mm Hex Bolt
10mm Lock Washer
10mm Flat Washer

Models with threaded insert use:
8mm x 30mm Hex Bolt
8mm Lock Washer
8mm Flat Washer

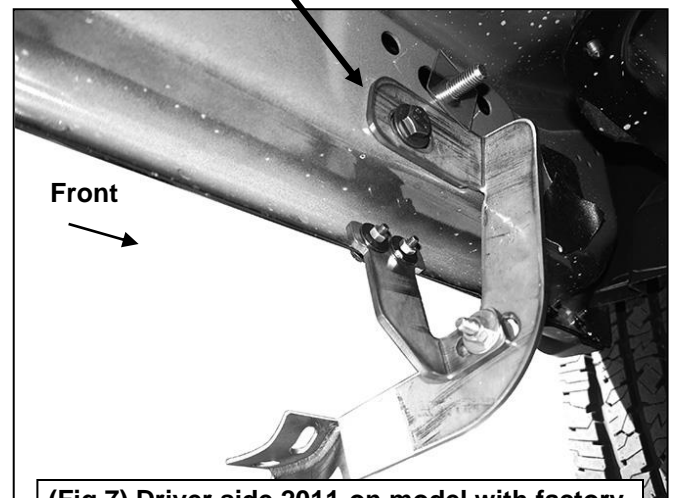

(Fig 7) Driver side 2011-on model with factory holes in pinch weld pictured.

IMPORTANT 2009-2010 models without holes in pinch weld will require drilling 1/4" holes through pinch weld to attach driver side front support bracket. Do complete installation of sidebars first, level sidebar before drilling holes for support bracket.

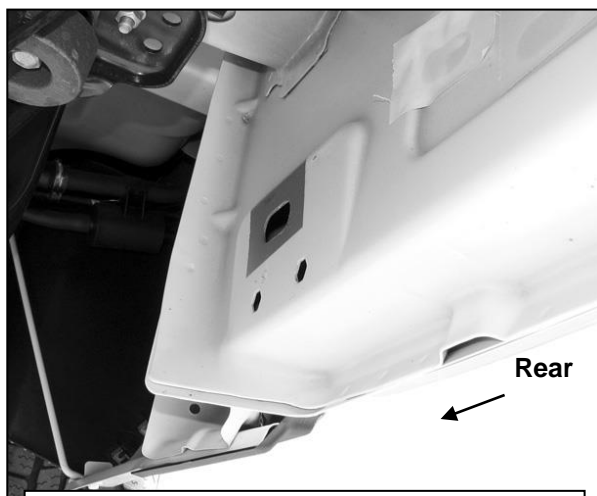

(Fig 8) Driver/Left rear mounting location

**5" OVAL STRAIGHT SIDEBARS
09-15 DODGE RAM 1500 REGULAR CAB
10-15 DODGE RAM 25-3500 REGULAR CAB**

12mm Flat Washer
12mm Lock Washer
12mm Hex Nut

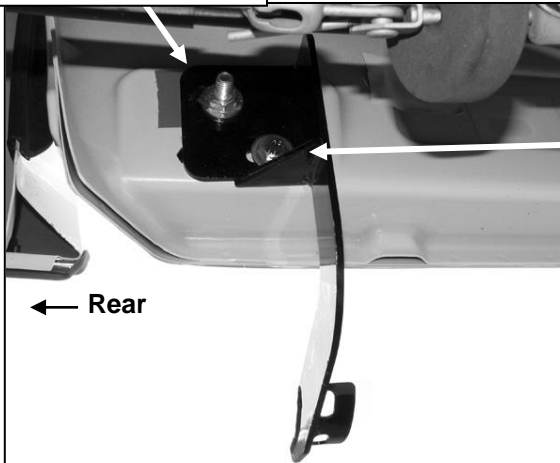

(Fig 9) Driver/Left rear Mounting Bracket

Models without threaded insert using Bolt/Nut Plate, use:
10mm x 35mm Hex Bolt
10mm Lock Washer
10mm Flat Washer

Models with threaded insert use:
8mm x 30mm Hex Bolt
8mm Lock Washer
8mm Flat Washer

8mm x 25mm Hex Bolts
8mm Flat Washers
8mm Lock Washers

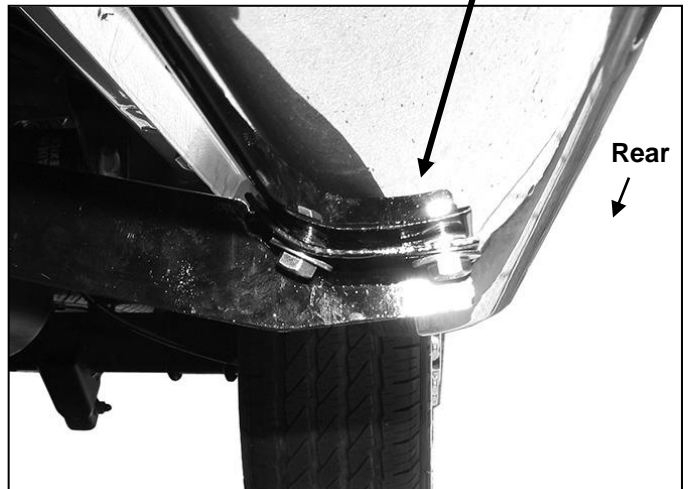

(Fig 10) Driver/Left rear Mounting Bracket

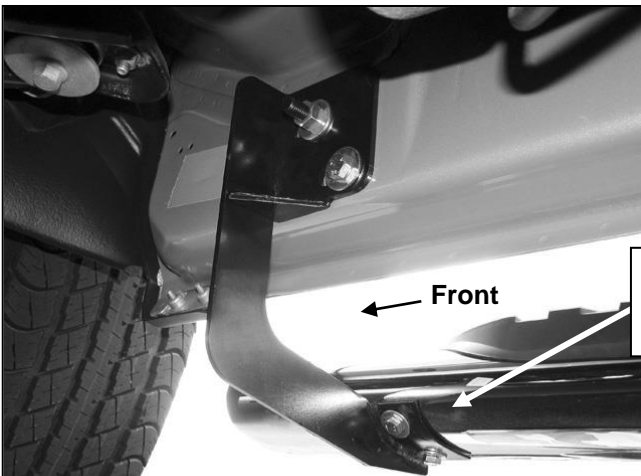

(Fig 11) Passenger/right front Mounting Bracket

8mm x 25mm Hex Bolts
8mm Flat Washers
8mm Lock Washers



Complete Installation