

INSTALLATION INSTRUCTIONS

4X SERIES 4" OVAL BENT END SIDE STEP

07-17 TOYOTA TUNDRA CREW MAX

PARTS LIST:

1	Driver Sidebar	1	Driver/Left Rear Mounting Bracket
1	Passenger Sidebar	1	Passenger/Right Rear Mounting Bracket
1	Driver/Left Front Mounting Bracket	12	8-1.25mm x 30mm Hex Bolts
1	Passenger/Right Front Mounting Bracket	12	8mm Lock Washers
1	Driver/Left Center Mounting Bracket	12	8mm x 24mm OD x 2mm Flat Washers
1	Passenger/Right Center Mounting Bracket	12	8mm x 25mm Combination Bolts

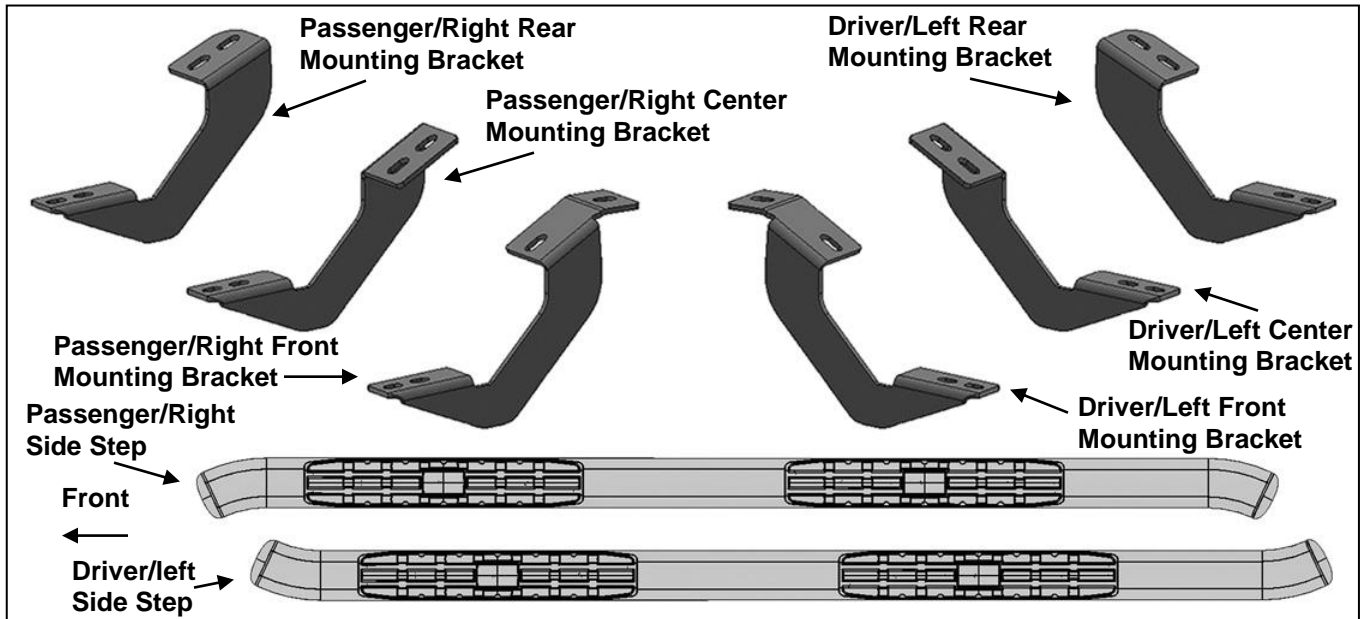

- 1. REMOVE CONTENTS FROM BOX. VERIFY ALL PARTS ARE PRESENT. READ INSTRUCTIONS CAREFULLY. ASSISTANCE IS RECOMMENDED.**
- Starting on the driver side front of the vehicle, remove the existing (2) factory bolts, (or plastic plugs), on the side panel located by the front tire opening, **(Figure 1)**. This will be the mounting location for the driver side front Mounting Bracket.
- Select the driver side Front Bracket, **(Figure 2)**. Attach the Bracket to the vehicle using the included (2) 8mm x 30mm Hex Bolts, (2) 8mm Lock Washers and (2) 8mm Flat Washers, **(Figure 3)**. Do not tighten hardware at this time.
- Move along the side panel to the next mounting location closest to the front Bracket, **(Figure 4)**. Repeat **Step 2 & 3** to install the driver side Center Bracket, **(Figures 5 & 6)**.
- Next, move to the last mounting location at the back of the cab. Select the driver side Rear Bracket, **(Figure 7)**. Repeat **Steps 2 & 3** to install the rear Bracket, **(Figure 8)**. **IMPORTANT:** There are (4) mounting locations along the side of the vehicle. Installation will use the 1st, 2nd and 4th mounting locations only.
- With assistance, carefully place the driver/left Side Step onto the (3) Brackets. Align the threaded holes in the bottom of the Side Step with the slots in the Mounting Brackets. Attach the Side Step to the Brackets with the included (6) 8mm x 25mm Combination Hex Bolts, **(Figures 3, 6 & 8)**. Do not tighten hardware at this time.
- Level and adjust the Side Step properly and tighten all hardware.
- Repeat **Steps 2—7** for passenger Side Step installation.
- Do periodic inspections to the installation to make sure that all hardware is secure and tight.

To protect your investment, wax this product after installing. Regular waxing is recommended to add a protective layer over the finish. Do not use any type of polish or wax that may contain abrasives that could damage the finish.

For stainless steel: Aluminum polish may be used to polish small scratches and scuffs on the finish. Mild soap may be used also to clean the Side Step.

For gloss black finishes: Mild soap may be used to clean the Side Step.

Driver Side Installation Pictured

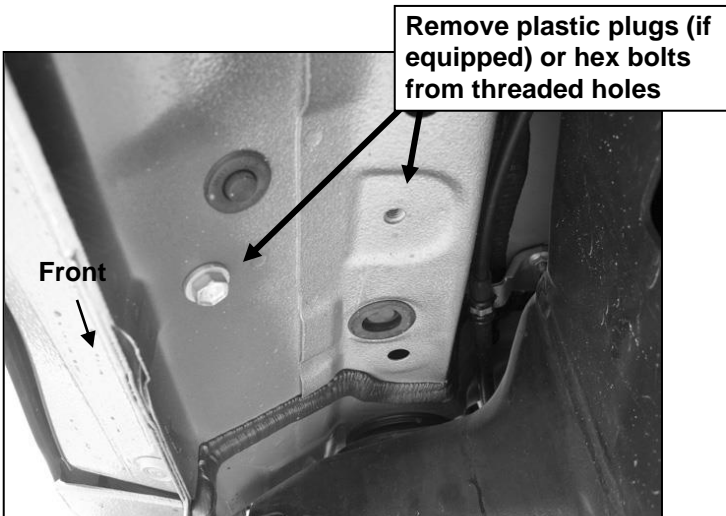

(Fig 1) Driver/Left Front Mounting Location Pictured

- (2) 8mm x 30mm Hex Bolts
- (2) 8mm Lock Washers
- (2) 8mm Flat Washers

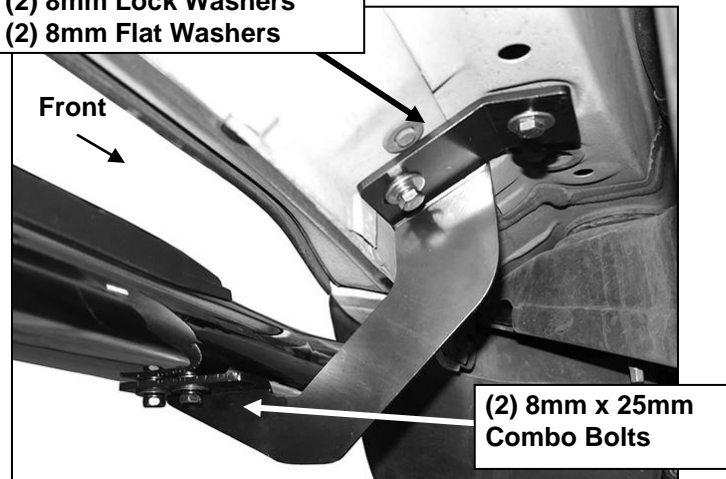

(Fig 3) Driver/Left Center Mounting Location Pictured

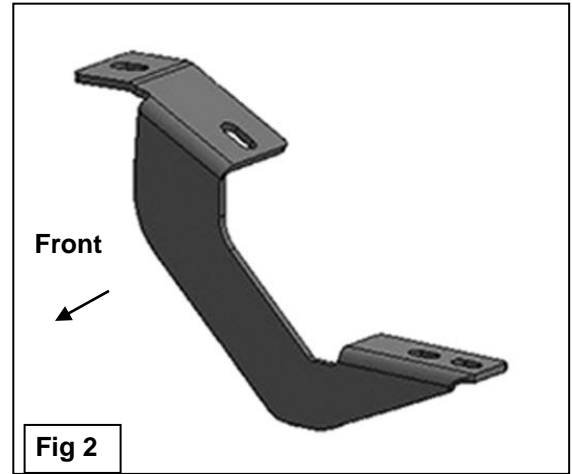

There are four sets of threaded holes in the side panel. Starting from the front of the vehicle, use the first, second, and fourth set of holes.

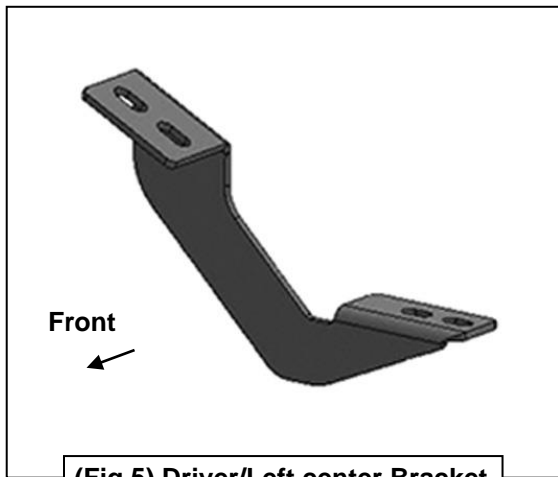

Driver Side Installation Pictured

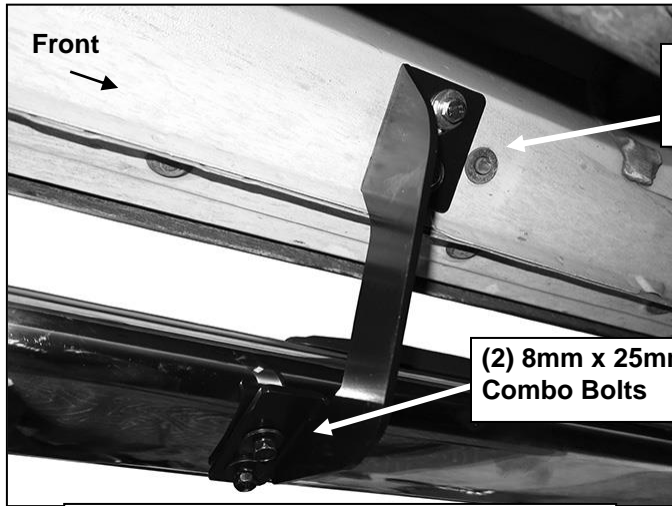

(Fig 6) Driver/Left center Bracket installed

There are four sets of threaded holes in the side panel. Starting from the front of the vehicle, use the first, second, and fourth set of holes.

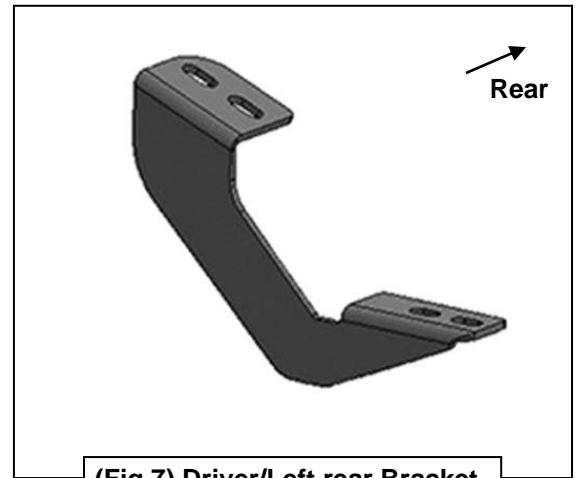

(Fig 7) Driver/Left rear Bracket

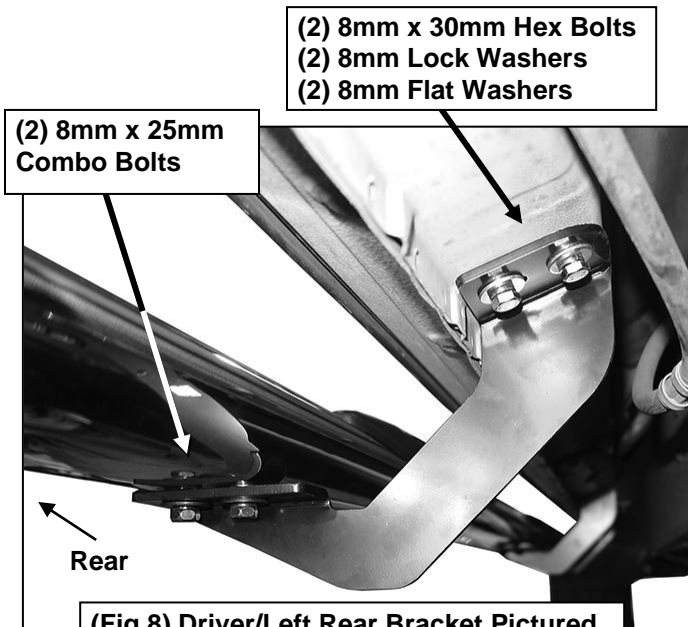

(Fig 8) Driver/Left Rear Bracket Pictured



Complete Installation