

INSTALLATION INSTRUCTIONS

4X SERIES 4" OVAL BENT END SIDE STEPS

99-16 FORD F-250/450 SUPERDUTY SUPER CREW CAB

4X SERIES 4" OVAL BENT END SIDE STEPS
99-16 FORD F-250/450 SUPERDUTY SUPER CREW CAB

PARTS LIST:

| | | | |
|----|-----------------------------------|----|-------------------------------------|
| 1 | Driver/Left Sidebar | 24 | 8-1.25mm x 30mm Hex Bolts |
| 1 | Passenger/Right Sidebar | 12 | 8-1.25mm x 25mm Combination Bolts |
| 3 | Driver/Left Mounting Brackets | 36 | 8mm ID x 24mm OD x 2mm Flat Washers |
| 3 | Passenger/Right Mounting Brackets | 24 | 8mm Lock Washers |
| 12 | 8mm Clip Nuts | 12 | 8mm Hex Nuts |

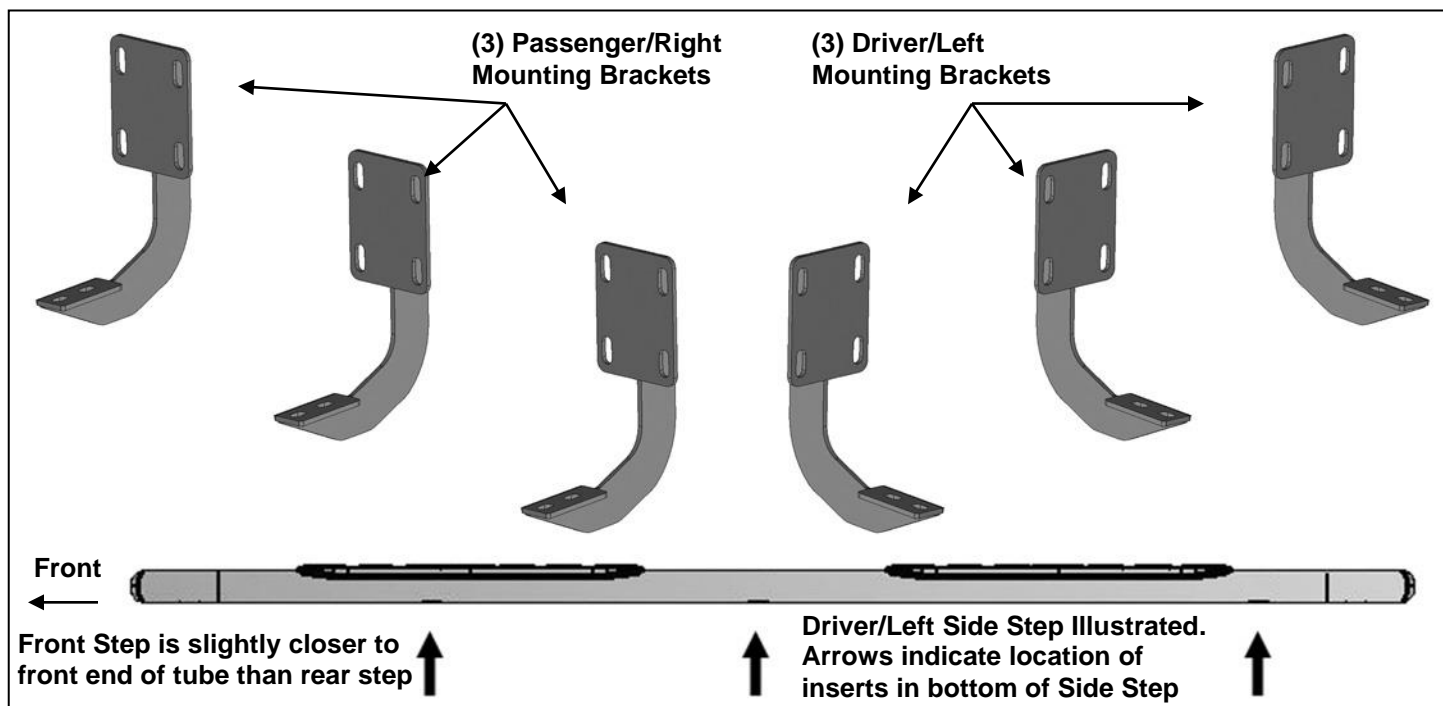

PROCEDURE:

1. REMOVE CONTENTS FROM BOX. VERIFY ALL PARTS ARE PRESENT. READ INSTRUCTIONS CAREFULLY BEFORE STARTING INSTALLATION. ASSISTANCE IS RECOMMENDED.
2. Starting on the driver side-front of the vehicle, locate the (5) pairs of factory holes along the bottom of the body, (pinch weld). Move to the 2nd pair of holes directly under the center of the front door, (**Figures 1 & 2**). Each mounting location on the inner body panel is comprised of a rectangular hole with a round hole on each side directly above each pair of holes in the pinch weld, (**Figures 1 & 3**).
3. Select (2) 8mm Clip Nuts. Insert Clip Nuts one at a time into the rectangular opening and slide the threaded hole outward towards the round hole. Line up the threaded hole in the Clip with the round hole next to the rectangular opening. **NOTE:** Threaded nut must go towards the inside of the side panel, (**Figures 3 & 4**).
4. Partially attach (1) driver side Bracket to the Clip Nuts with the included (2) 8mm x 30mm Hex Bolts, (2) 8mm Lock Washers and (2) 8mm Flat Washers, (**Figure 5**). **NOTE:** Cradles on the Mounting Brackets should face the front of the vehicle.
5. Bolt the (2) bottom holes in the Mounting Bracket to the (2) holes in the pinch weld with the included (2) 8mm x 30mm Hex Bolts, (4) 8mm Flat Washers, (2) 8mm Lock Washers and (2) 8mm Hex Nuts, (**Figure 5**). **NOTE:** Insert the Hex Bolt with Flat Washer through the pinch weld first then through the Bracket from the outside to inside. Do not tighten hardware at this time.
6. Move along the vehicle to the next, (center), mounting location, (**Figure 6**). Repeat **Steps 2—5** to install (1) driver side Bracket in the center location. **NOTE:** There are (5) mounting locations along the inner body panel. Side Step installation will use the 2nd, 3rd and 5th mounting

locations, **(Figure 1)**. If you are not sure which sets of mounting holes to use, hold the driver/left Side Step up in the approximate location and line up the threaded inserts on the bottom of the Side Step with the holes in the pinch weld.

7. Repeat **Steps 2—5** to install the rear driver side Bracket in the last location at the back of the cab, **(Figure 8)**.
8. Select the driver/left Side Step. Carefully position the Side Step onto the (3) Mounting Brackets. **IMPORTANT:** Do not slide, (front to back or rotate), the Side Step on the Brackets or damage to the finish may result. Attach the Side Step to the Mounting Brackets with (6) 8mm x 25mm Combination Hex Bolts, **(Figures 7 & 8)**. Do not tighten at this time.
9. Level and adjust Side Step properly and tighten all hardware.
10. Repeat **Steps 2—9** for passenger/right Side Step installation.
11. Do periodic inspections to the installation to make sure that all hardware is secure and tight.

To protect your investment, wax this product after installing. Regular waxing is recommended to add a protective layer over the finish. Do not use any type of polish or wax that may contain abrasives that could damage the finish.

For stainless steel: Aluminum polish may be used to polish small scratches and scuffs on the finish. Mild soap may be used also to clean the Side Step.

For gloss black finishes: Mild soap may be used to clean the Side Step.

Driver Side Installation Pictured

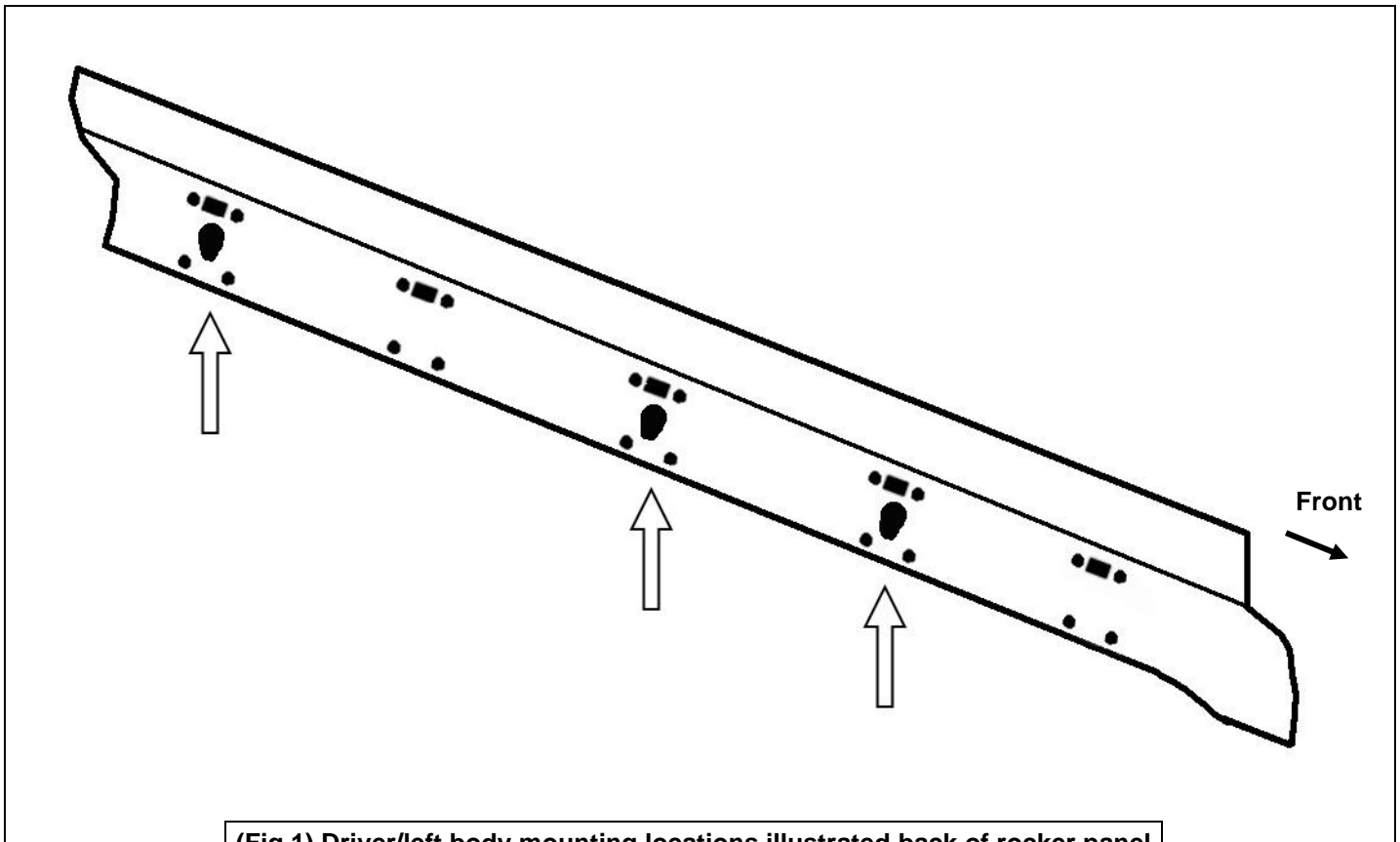

Driver Side Installation Pictured

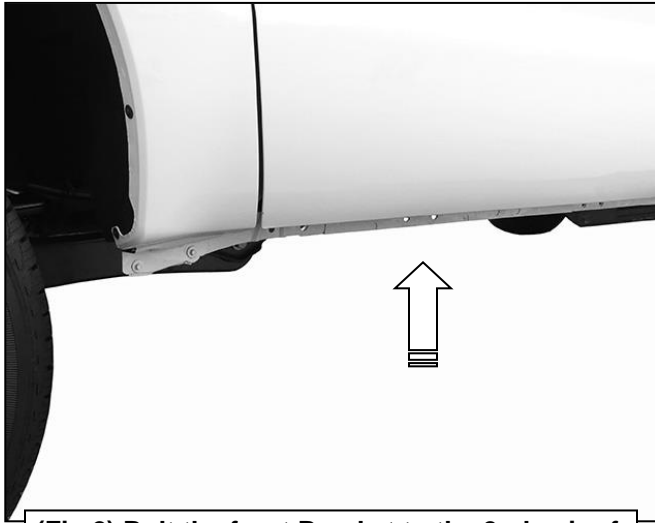

(Fig 2) Bolt the front Bracket to the 2nd pair of factory holes in the bottom of the pinch weld

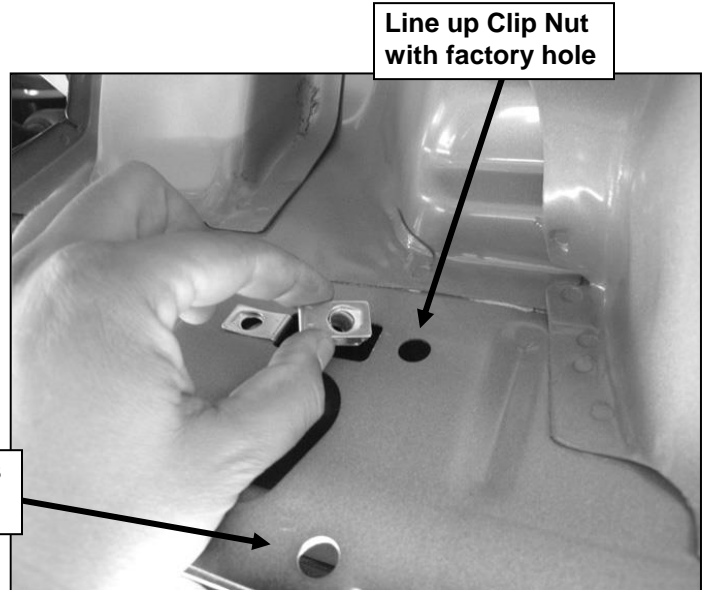

Line up Clip Nut with factory hole

Factory holes in pinch weld

(Fig 3) Typical Mounting Location

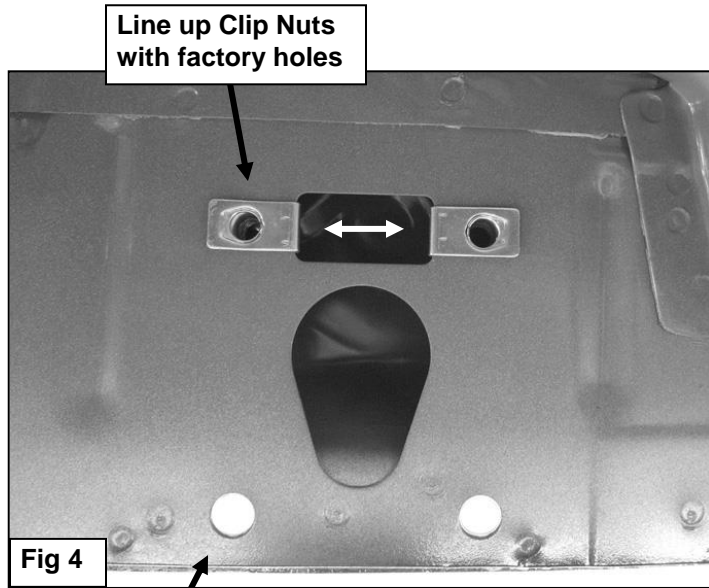

Line up Clip Nuts with factory holes

- (2) 8mm Clip Nuts
- (2) 8mm x 30mm Hex Bolts
- (2) 8mm Lock Washers
- (2) 8mm Flat Washers

Fig 4

Factory holes in pinch weld pictured from behind body panel

- (2) 8mm x 30mm Hex Bolts
- (4) 8mm Flat Washers
- (2) 8mm Lock Washers
- (2) 8mm Hex Nuts

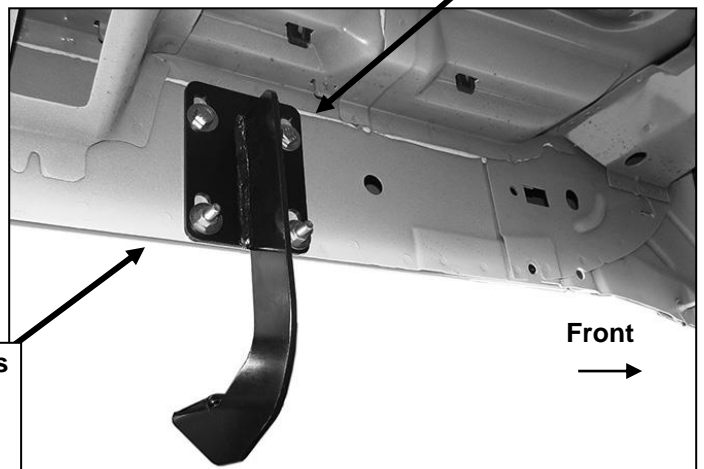

Front
→

(Fig 5) Driver/left front Bracket installation pictured

Driver Side Installation Pictured



(Fig 6) Driver/left center mounting location

- (2) 8mm x 30mm Hex Bolts
- (4) 8mm Flat Washers
- (2) 8mm Lock Washers
- (2) 8mm Hex Nuts



(Fig 7) Driver/left front Bracket installation pictured

- (2) 8mm x 25mm
Combination Bolts

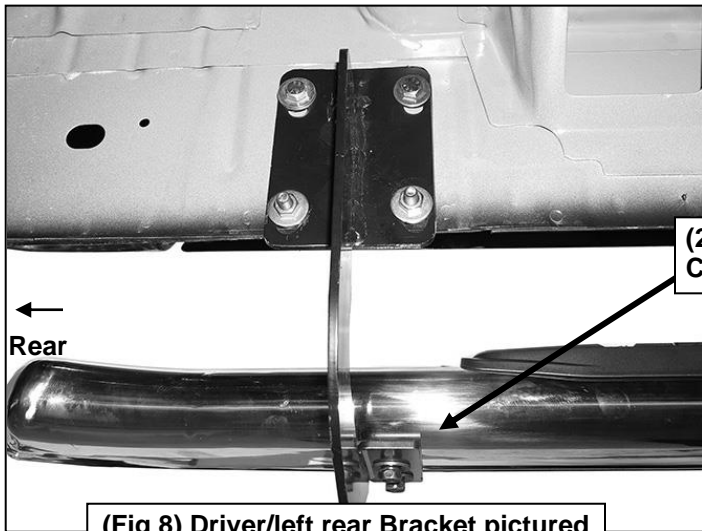

(Fig 8) Driver/left rear Bracket pictured

- (2) 8mm x 25mm
Combination Bolts



Complete Installation