

STX300 RUNNING BOARD BRACKET KIT
99-06, 07 "CLASSIC" SILVERADO/SIERRA EXTRA CAB

PARTS LIST:

2	Driver/left Front/Center Mounting Brackets	6	12mm Lock Washers
2	Passenger/right Front/Center Mounting Brackets	6	12mm Hex Nuts
1	Driver/left Rear Mounting Bracket	12	8-1.25mm x 25mm Hex Bolts
1	Passenger/right Rear Mounting Bracket	24	8mm x 22mm x 2mm Washers
3	Driver/left Support Brackets	12	8-1.25mm Nylon Lock Nuts
3	Passenger/right Support Brackets	12	6mm T-Bolts
6	12-1.75mm x 35mm Bolt Plates	12	6mm x 22mm OD x 2mm Flat Washers
6	12mm Plastic Retainers	12	6mm Lock Washers
6	12mm x 37mm x 3mm Flat Washers	12	6mm Hex Nuts

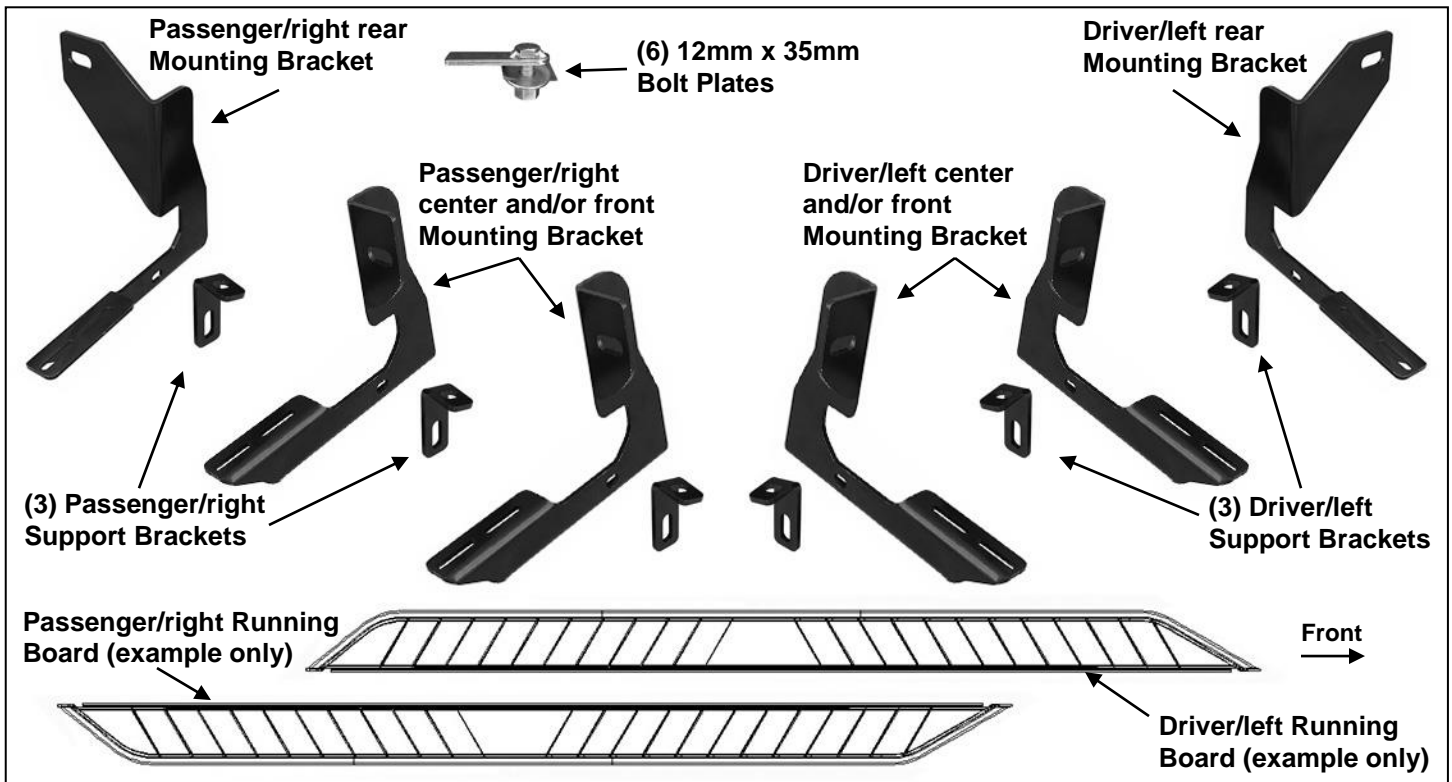

PROCEDURE:

REMOVE CONTENTS FROM BOX. VERIFY ALL PARTS ARE PRESENT. READ INSTRUCTIONS CAREFULLY BEFORE STARTING THE INSTALLATION. DRILLING IS REQUIRED. ASSISTANCE IS RECOMMENDED.

1. Start the installation under the front of the driver side of the vehicle. Locate the factory hole in the inner body panel closest to the front wheel opening, **(Figures 1 & 2)**. **NOTE:** Holes may be covered with sealing tape or rubber plugs. Remove cover/plug as necessary.
2. Select (1) 12mm Bolt Plate and (1) 12mm Plastic Retainer washer, **(Figure 3A)**. Thread the Retainer part way onto the Bolt Plate. **IMPORTANT:** The Plastic Retainer is designed to help prevent the Bolt Plate from falling into the body panel and to aid in Bracket installation.
3. Insert the Bolt Plate with Retainer into the factory hole, **(Figure 3B)**. Hold the threaded end of the Bolt Plate and continue to thread the Retainer down until it is tight against the body panel, **(Figure 4)**.

STX300 RUNNING BOARD BRACKET KIT
99-06, 07 "CLASSIC" SILVERADO/SIERRA EXTRA CAB

4. Select (1) driver side front/center Bracket and (1) driver side Support Bracket, **(Figures 5A & 5B)**. Bolt the Support Bracket to the front side of the Mounting Bracket with (1) 8mm Hex Bolt, (2) 8mm Flat Washers and (1) 8mm Nylon Lock Nut, **(Figure 6)**. Do not tighten hardware.
 5. Attach the Bracket assembly to the 12mm Bolt Plate with (1) 12mm Flat Washer, (1) 12mm Lock Washer and (1) 12mm Hex Nut, **(Figure 6)**. Snug but do not fully tighten hardware.
 6. Next, move along the side of the vehicle to the center mounting location just past the center body mount where the front door meets the door jamb, **(Figures 1 & 7)**. Repeat **Steps 1—5** to attach the center Mounting Bracket and Support Bracket, **(Figures 8 & 9)**. Leave hardware loose at this time.
 7. Continue along the vehicle to the very back of the cab. Locate the last factory hole along the inner body panel, **(Figures 1 & 10)**. Repeat **Steps 1—6** to attach the driver side rear Mounting Bracket and Support Bracket to the back of the cab, **(Figure 11)**.
 8. Once all (3) Brackets have been fully installed, select the passenger side Running Board. **NOTE:** Angled end of Running Board is the front, **(see Page 1)**. Locate the two channels in the bottom of the Running Board. Slide (3) T-Bolts into each channel, **(Figure 12)**.
 9. Hold the Running Board up in approximate position and slide the T-Bolts along the channel to line up with the (3) Mounting Brackets. Tilt the Board up at a slight angle and push back against the vehicle until the T-Bolts fit into the slots in the Brackets.
 10. Secure the Running Board to the Brackets with (6) 6mm Flat Washers, (6) 6mm Lock Washers and (6) 6mm Hex Nuts, **(Figures 15 & 16)**. Do not tighten hardware at this time. **NOTE:** The Running Board is designed to fit close to the vehicle. It may be necessary to loosen the Bracket hardware and tilt the Brackets downward to insert the Running Board between the Brackets and the body.
 11. With assistance, level and adjust the Running Board and tighten the 12mm hardware securing the Mounting Brackets to the Bolt Plates only, **(Figures 6, 9 & 11)**. Use clamps if necessary to temporarily hold the Support Brackets up to the bottom of the pinch weld.
 12. Starting at the front, line up the edge of the Support Bracket with the edge of the pinch weld. Mark the slot location onto the pinch weld and move the Support Bracket out of the way, **(Figure 13)**. Use a 5/16" drill bit to drill a hole through the pinch weld. Bolt the Support Bracket to the bottom of the pinch weld with (1) 8mm Hex Bolt, (2) 8mm Flat Washers and (1) 8mm Nylon Lock Nut, **(Figure 14)**. **NOTE:** Do not drill too close to the edge of the pinch weld.
- IMPORTANT!** Any cutting or drilling tool may break or shatter. Government regulations require safety glasses & equipment at all times when cutting or drilling.
13. Repeat **Steps 11 & 12** to drill and bolt the center and rear Support Brackets to the bottom of the pinch weld, **(Figures 15 & 16)**.
 14. Level and adjust the Running Board and tighten all hardware.
 15. Repeat **Steps 1—14** for passenger side Running Board installation.
 16. Do periodic inspections to the installation to make sure that all hardware is secure and tight.

To protect your investment, wax this product after installing. Regular waxing is recommended to add a protective layer over the finish. Do not use any type of polish or wax that may contain abrasives that could damage the finish.

For stainless steel: Aluminum polish may be used to polish small scratches and scuffs on the finish. Mild soap may be used also to clean the Running Board.

For gloss black finishes: Mild soap may be used to clean the Running Board.

STX300 RUNNING BOARD BRACKET KIT
99-06, 07 "CLASSIC" SILVERADO/SIERRA EXTRA CAB
Driver Side Installation Pictured

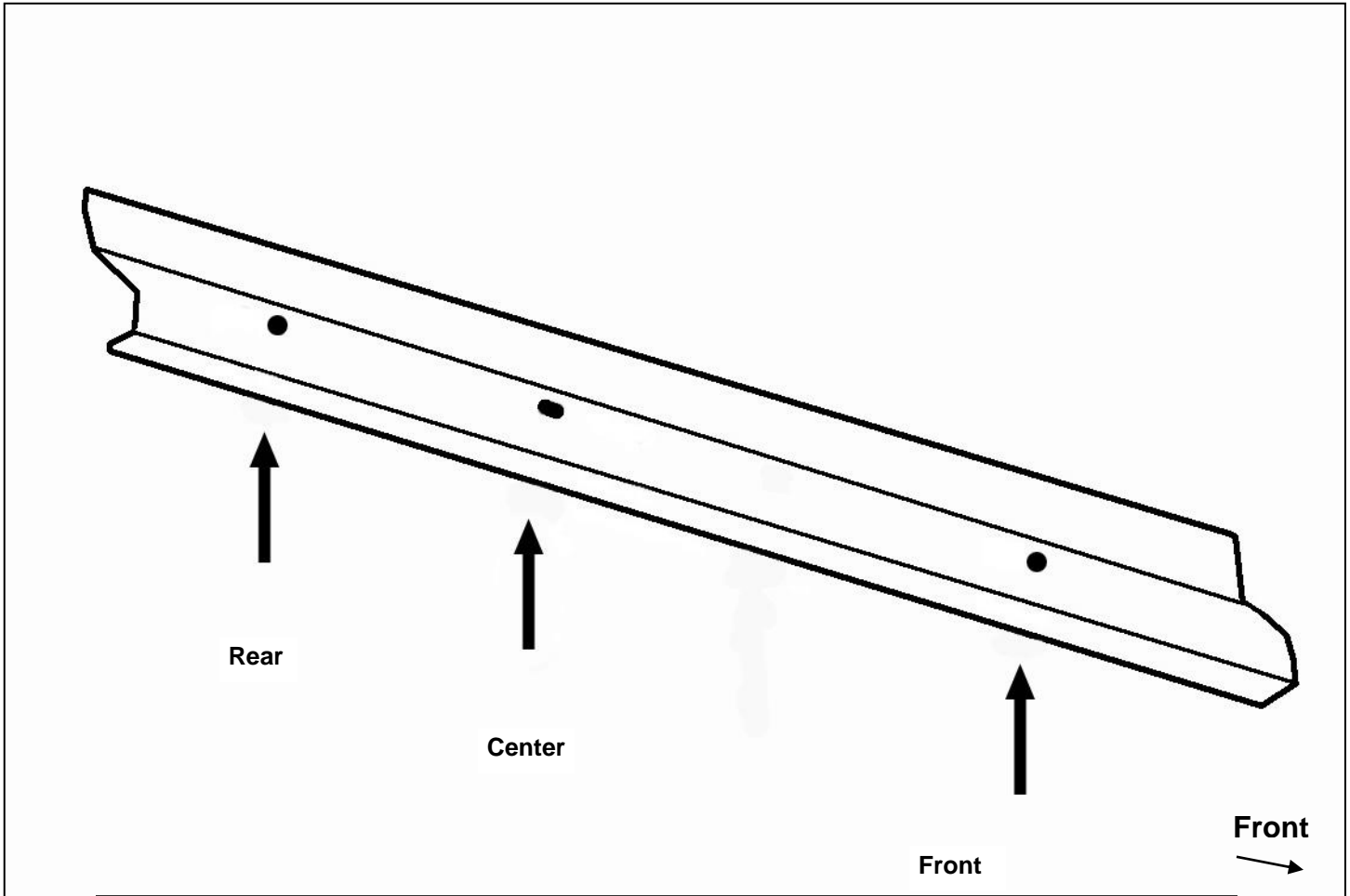

(Fig 1) Driver side mounting locations for example only, actual layout may vary by model year

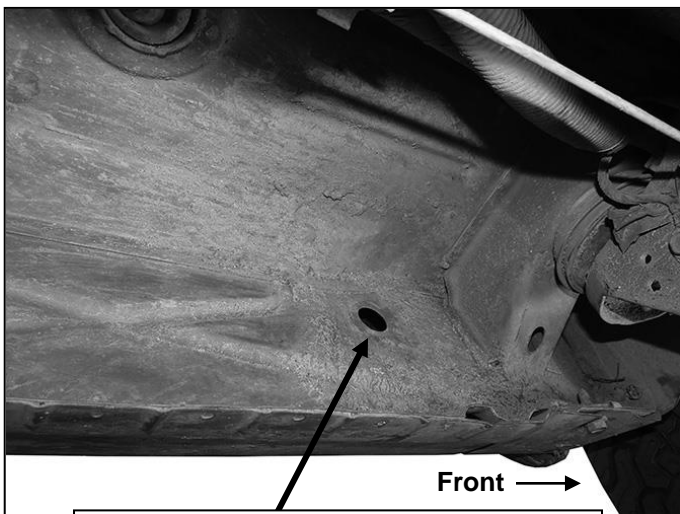

(Fig 2) Driver/left front location pictured

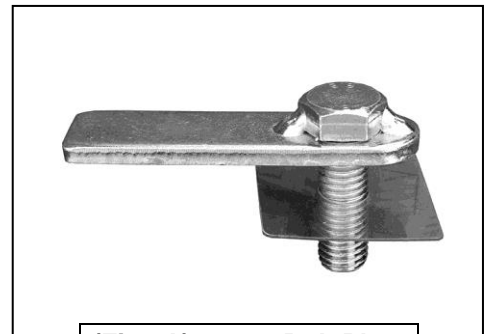

(Fig 3A) 12mm Bolt Plate
with Plastic Retainer

STX300 RUNNING BOARD BRACKET KIT
99-06, 07 "CLASSIC" SILVERADO/SIERRA EXTRA CAB
Driver Side Installation Pictured

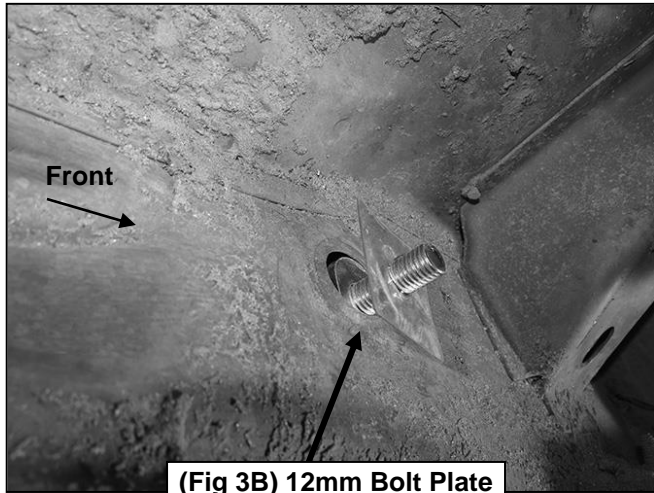

(Fig 3B) 12mm Bolt Plate with Plastic Retainer

Thread Plastic Retainer down tight against the body panel

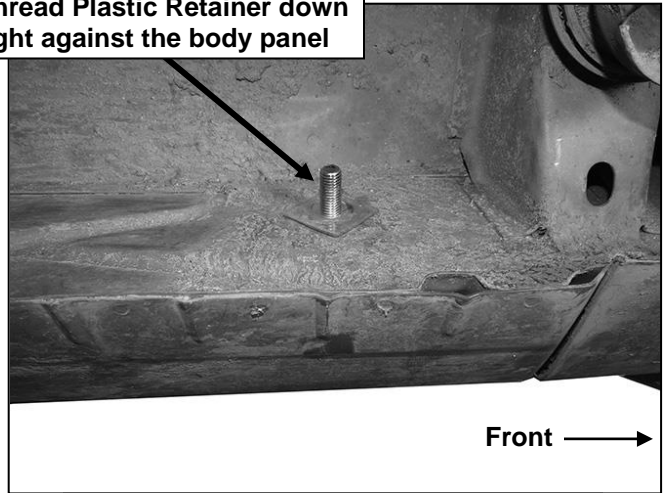

(Fig 4) Driver/left front location pictured



(Fig 5A) Driver/left Support Bracket

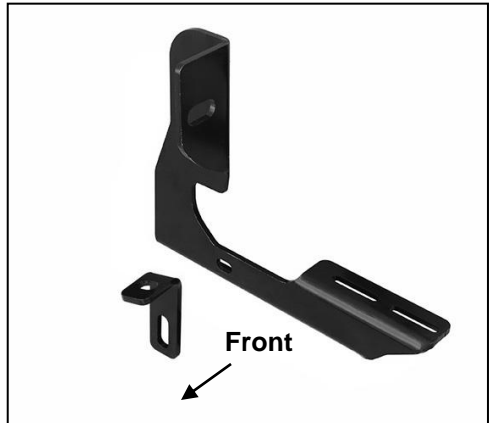

(Fig 5B) Driver/left front and/or center Mounting Bracket and Support Bracket

12mm Flat Washer
 12mm Lock Washer
 12mm Hex Nut

8mm x 25mm Hex Bolt
 (2) 8mm Flat Washers
 8mm Nylon Lock Nut

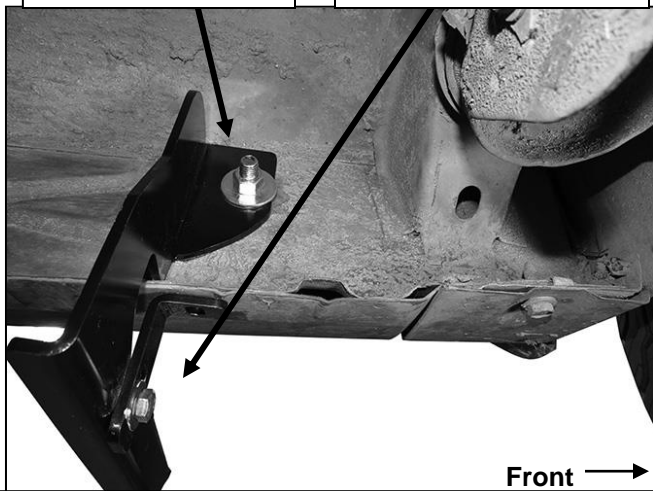

(Fig 6) Driver/left front Bracket installation pictured

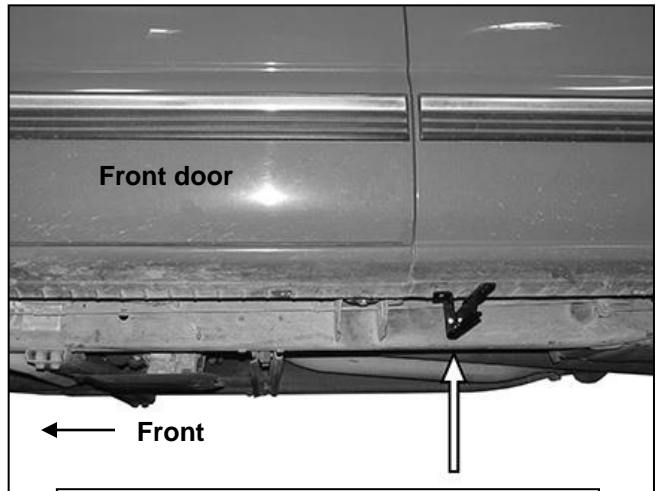

(Fig 7) Driver/left center Bracket location

STX300 RUNNING BOARD BRACKET KIT
99-06, 07 "CLASSIC" SILVERADO/SIERRA EXTRA CAB
Driver Side Installation Pictured

12mm Bolt Plate with Plastic Retainer

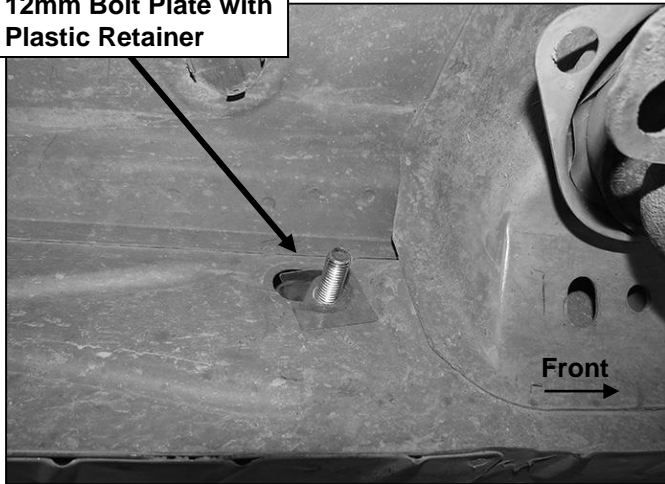

(Fig 8) Driver/left center location pictured

12mm Flat Washer
 12mm Lock Washer
 12mm Hex Nut

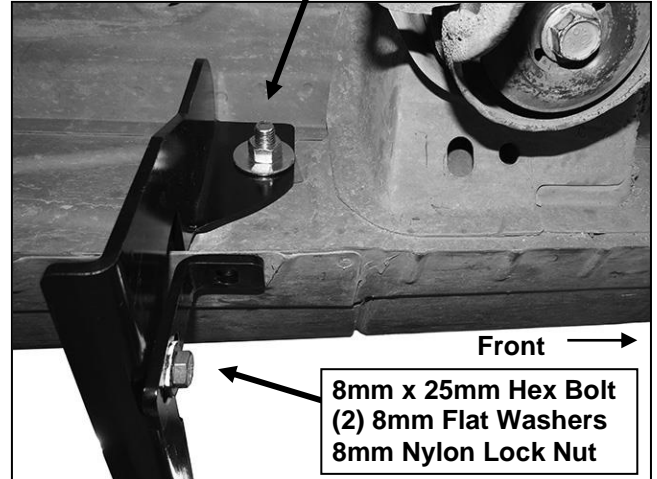

(Fig 9) Driver/left center location pictured

8mm x 25mm Hex Bolt
 (2) 8mm Flat Washers
 8mm Nylon Lock Nut

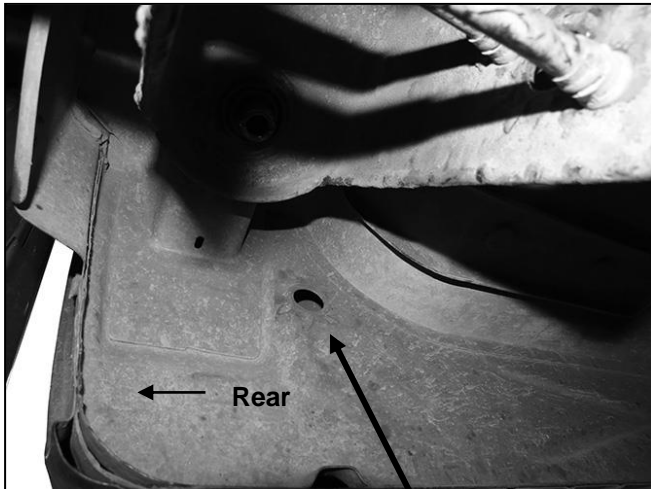

(Fig 10) Driver/left rear location pictured

12mm Flat Washer
 12mm Lock Washer
 12mm Hex Nut

8mm x 25mm Hex Bolt
 (2) 8mm Flat Washers
 8mm Nylon Lock Nut

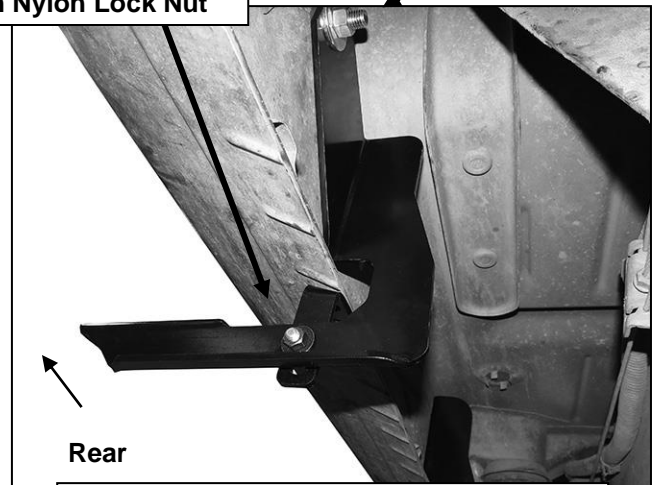

(Fig 11) Driver/left rear Bracket installed

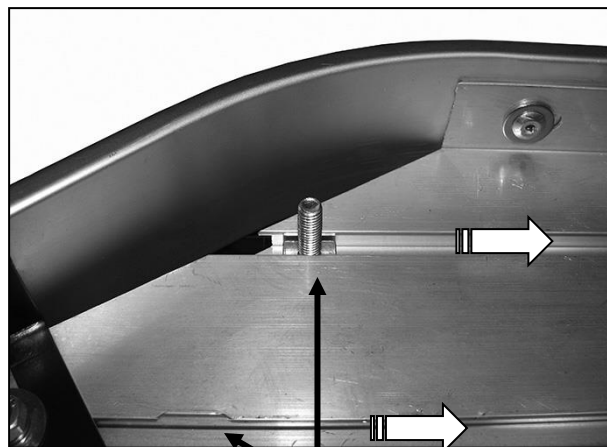

(Fig 12) Slide T-Bolts into channels

STX300 RUNNING BOARD BRACKET KIT
99-06, 07 "CLASSIC" SILVERADO/SIERRA EXTRA CAB
Driver Side Installation Pictured

Drill 5/16" hole through pinch weld for Support Bracket



(Fig 13) Mark location onto bottom of pinch weld

8mm x 25mm Hex Bolt
 (2) 8mm Flat Washers
 8mm Nylon Lock Nut

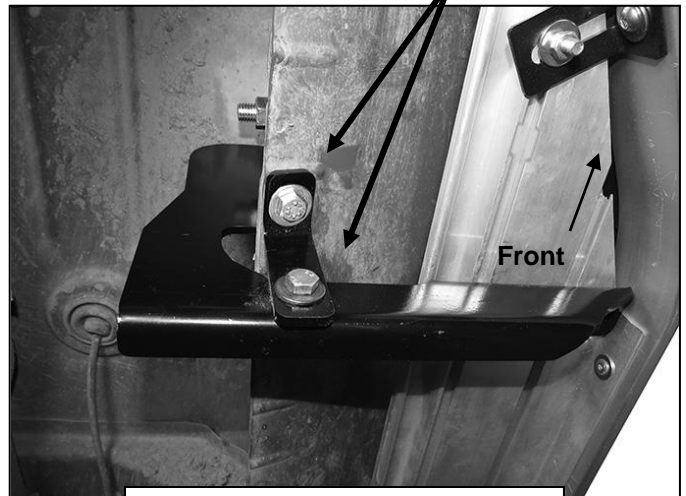

(Fig 14) Driver/left front pictured

(2) 6mm Flat Washers
 (2) 6mm Lock Washers
 (2) 6mm Hex Nuts

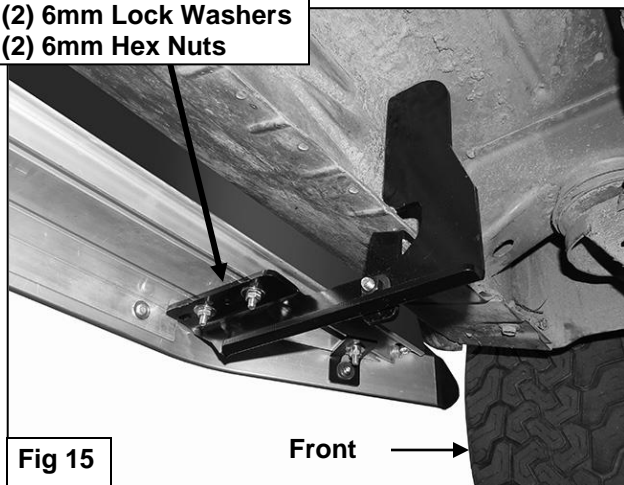
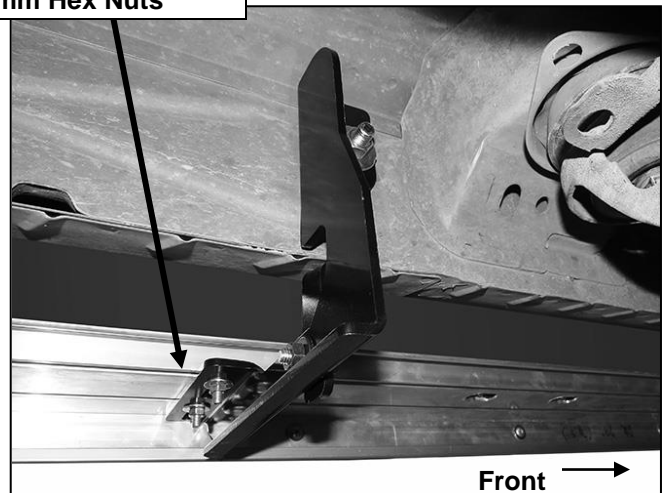

Fig 15

Front →

(2) 6mm Flat Washers
 (2) 6mm Lock Washers
 (2) 6mm Hex Nuts



(Fig 16) Driver/left center Bracket pictured

Front →



Complete Installation