

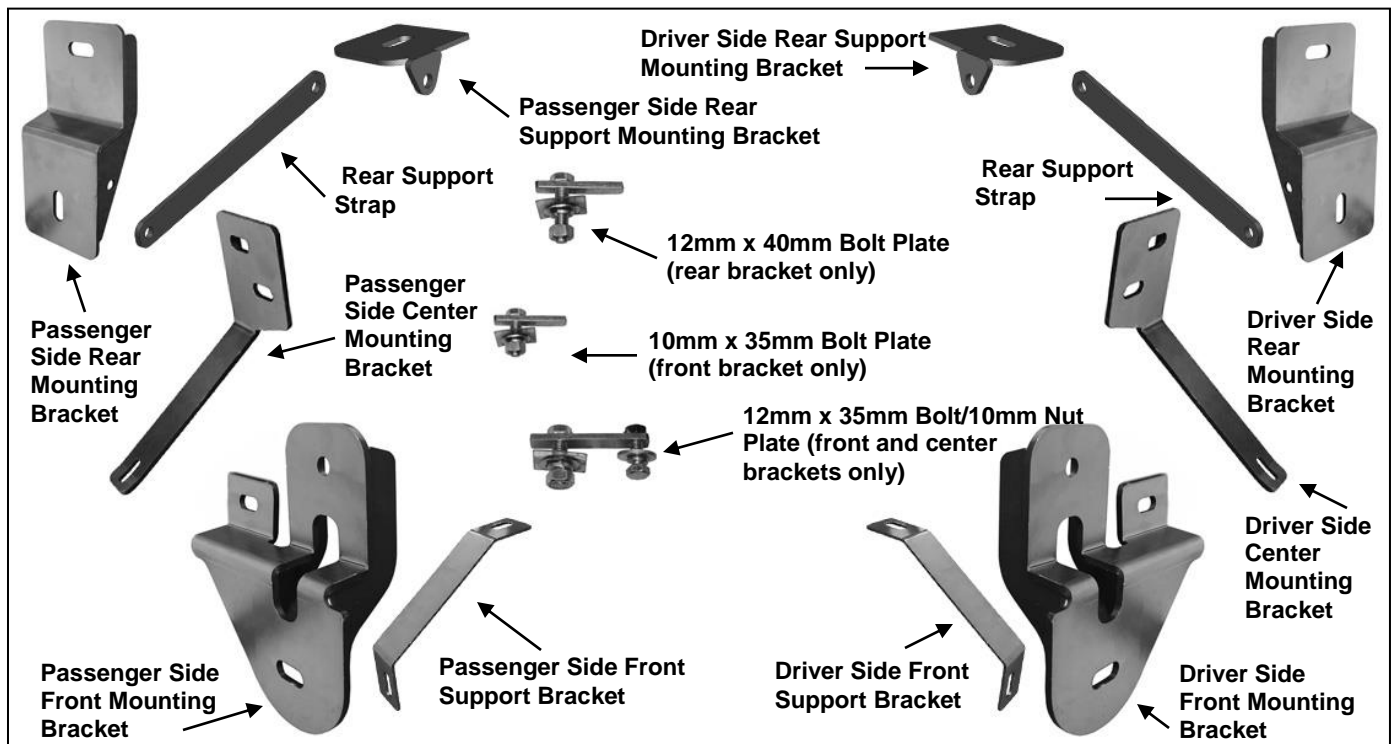
INSTALLATION INSTRUCTIONS

3" ROUND & 4" OVAL SIDEBAR (90-DEG BENT END)

2010-16 DODGE RAM 25-3500 MEGA CAB

PARTS LIST:

Qty	Description	Qty	Description
1	Driver/Left Sidebar	4	12mm x 32mm OD x 3mm Flat Washers
1	Passenger/Right Sidebar	4	12mm Lock Washers
1	Driver/Left Front Mounting Bracket	4	12mm Hex Nuts
1	Passenger/Right Front Mounting Bracket	6	12mm Plastic Retainers
1	Driver/Left Front Support Bracket	2	10-1.5mm x 35mm Bolt Plates
1	Passenger/Right Front Support Bracket	1	10mm Fish Wire
1	Driver/Left Center Mounting Bracket	2	10mm Plastic Retainers
1	Passenger/Right Center Mounting Bracket	8	10-1.50mm x 35mm Hex Bolts
2	Rear Mounting Brackets	6	10mm x 30mm OD x 2.5mm Flat Washers
1	Driver/Left Rear Support Mounting Bracket	8	10mm x 20mm OD x 2.5mm Flat Washers
1	Passenger/Right Support Mounting Bracket	10	10mm Lock Washers
2	Rear Support Strap	6	10mm Hex Nuts
4	1/2" x 2" Hex Bolts	4	8-1.25mm x 30mm Hex Bolts
4	1/2" Lock Washers	2	8-1.25mm x 25mm Hex Bolts
4	1/2" X 1-1/2" OD x 1/8" Flat Washers	4	8mm x 28mm x 3mm Large Flat Washers
4	12-1.75mm x 35mm Bolt/10-1.5mm Nut Plates	2	8mm x 24mm OD x 2mm Flat Washers
2	12-1.75mm x 40mm Bolt Plates	6	8mm Lock Washers



PROCEDURE:

- 1. REMOVE CONTENTS FROM BOX. VERIFY ALL PARTS ARE PRESENT. READ INSTRUCTIONS CAREFULLY BEFORE STARTING INSTALLATION.**
- Starting at the driver side-front of the vehicle, remove the tape covering the factory oval holes in the inner body panel located by the front tire, **(Figure 1)**. Select the 10mm Fish Wire, 10mm Bolt Plate and 10mm Plastic Retainer. Insert the coiled end of the Fish Wire into the smaller forward slot closest to the front tire opening, **(Figure 1)**. Feed the Fish Wire back toward and out of the larger oval hole.
- Thread the coiled end of the Fish Wire onto the threaded end of the Bolt Plate, **(Figure 2)**. Carefully pull the straight, forward end of the Fish Wire until the threaded end of the Bolt Plate is pulled into the forward hole, **(Figure 3)**. Hold the Bolt Plate in place and unscrew the Fish Wire. Thread the Plastic Retainer onto the Bolt Plate to hold it in place, **(Figure 4B)**. **IMPORTANT:** The Retainer is designed to keep the Bolt Plate from falling into the body panel and to aid in Bracket installation.
- Determine correct procedure for your model/year.

Models without factory threaded inserts in body panel:

- a. Partially thread a 12mm Plastic Retainer onto the threaded end of a 12mm Bolt and Nut Plate, **(Figure 5A)**. Insert the Bolt and Nut Plate into the larger rear oval hole and tighten the Plastic Retainer, **(Figure 5B)**. Proceed to **Step 5**.

Mid 2015-on models with factory threaded inserts:

- a. **NOTE:** The 12mm Bolt/Nut Plate is not required for this installation. Skip to **Step 5**.

5. Select the driver side front Mounting Bracket. Position the Mounting Bracket onto the front 10mm Bolt Plate. Attach the Bracket to the Bolt Plate with (1) 10mm Flat Washer, (1) 10mm Lock Washer and (1) 10mm Hex Nut, **(Figure 6)**. Do not tighten at this time.

Driver side up to mid 2015 without factory threaded inserts:

- a. Rotate the 12mm Bolt and Nut plate until the threaded nut lines up with the remaining hole in the Mounting Bracket and body, **(Figure 5B)**. Attach the Bracket to the threaded Nut Plate with (1) 10mm x 35mm Hex Bolt, (1) 10mm Lock Washer and (1) 10mm Flat Washer, **(Figure 6)**.

Driver side mid 2015-on with factory threaded inserts:

- a. Attach the Bracket to the threaded insert with (1) 8mm x 30mm Hex Bolt, (1) 8mm Lock Washer and (1) 8mm x 28mm Large Flat Washer instead of the 10mm hardware, **(Figure 7)**. Do not tighten hardware at this time.

Passenger side all model years:

- a. Repeat the previous applicable driver side instructions to attach the bottom/rear mounting hole on the passenger side front Bracket to the Bolt/Nut plate or threaded insert if equipped, **(Figures 6 & 7)**. Do not tighten hardware at this time.
6. Remove the driver side front factory body bolt and washer. Select the driver side Front Support Bracket. Insert the factory body bolt and washer through the slot in the Support Bracket and up into its original position, **(Figure 8)**. Line up the other end of the Support Bracket with the oval hole in the Front Mounting Bracket. Snug but do not tighten hardware.
7. Move to the mid point on the driver side of the vehicle and remove the tape covering the factory oval hole in the inner body panel, **(Figure 9B)**. Select and install a 12mm Bolt and Nut Plate with 12mm Plastic Retainer as described in **Step 3, (Figure 9A & 9B)**.
8. Select the driver side Center Mounting Bracket. Attach the Mounting Bracket to the Bolt and Nut Plate with (1) 12mm Flat Washer, (1) 12mm Lock Washer and (1) 12mm Hex Nut, **(Figure 10)**. Rotate the Bolt and Nut plate until the Nut end lines up with the remaining hole in the Mounting Bracket and body. Thread (1) 10mm x 35mm Hex Bolt, (1) 10mm Flat Washer and (1) 10mm Lock Washer into the threaded nut. **On models with factory installed threaded insert**, use the Bolt and Nut Plate to attach the top of the Bracket but attach the bottom of the Bracket to the threaded insert with (1) 8mm x 30mm Hex Bolt, (1) 8mm Lock Washer and (1) 8mm x 28mm Large Flat Washer instead of the 10mm hardware, **(Figure 10)**. Do not tighten hardware at this time.
9. Next, move to the rear mounting location and remove the tape covering the single factory hole, **(Figure 11B)**. Select (1) 12mm Bolt Plate and 12mm Plastic Retainer, **(Figure 11A)**. Partially thread the Retainer onto the Bolt Plate. Insert the Bolt Plate into the factory oval hole. Select (1) Rear Mounting Bracket. Attach the Bracket to the Bolt Plate with (1) 12mm Flat Washer, (1) 12mm Lock Washer and (1) 12mm Hex Nut. Push Bracket up against the body as you tighten the hardware, **(Figure 12)**.
10. Remove the driver side rear factory body bolt and washer. Select the driver side Rear Support Mounting Bracket, **(Figure 13)**. Insert the factory body bolt and washer through the Support Mounting Bracket and up into its original position. Next, select (1) Rear Support Strap and bolt it to the mounting tab on the Rear Support Mounting Bracket and to the Rear Mounting Bracket with (2) 10mm x 35mm Hex Bolts, (4) 10mm x 20mm OD Small Flat Washers, (2) 10mm Lock Washers and (2) 10mm Hex Nuts, **(Figure 14)**. Snug but do not tighten hardware at this time.
11. Select the driver Sidebar and with assistance, carefully fasten it to the front and rear Mounting Brackets with the included (2) 1/2" x 2" Hex Head Bolts, (2) 1/2" Lock Washers, and (2) 1/2" Flat Washers, **(Figure 14 & 15)**. Do not tighten at this time.
12. Level and align Sidebar properly; then snug all hardware on the front and rear Mounting Brackets first.
13. Line up the Center Mounting Bracket with the threaded insert in the Sidebar. Insert (1) 8mm x 25mm Hex Bolt, (1) 8mm Lock Washer and (1) 8mm STD Flat Washer through the Center Bracket and into the threaded insert in the Sidebar, **(Figure 16)**. Slowly tighten the Mounting Hardware.
14. Check the Sidebar for level and adjust as necessary. Tighten all hardware at this time.

15. Repeat **Steps 2—14** for passenger Sidebar installation. **NOTE** Pay close attention to specific information regarding passenger side front Bracket installation in **Step 5**.

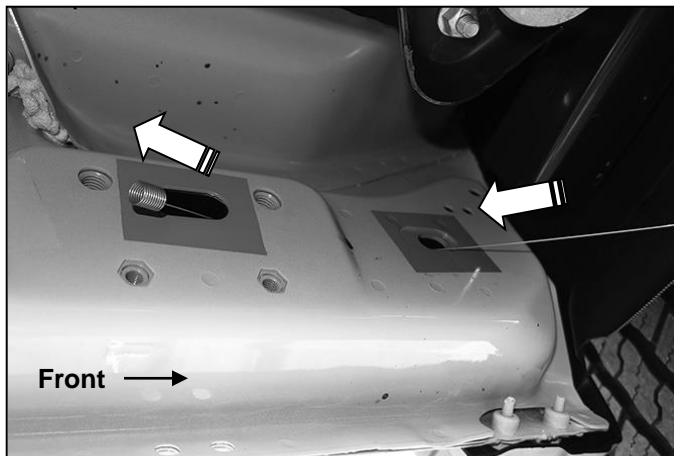
16. Do periodic inspections to the installation to make sure all hardware is secure and tight.

To protect your investment, wax this product after installing. Regular waxing is recommended to add a protective layer over the finish. Do not use any type of polish or wax that may contain abrasives that could damage the finish.

For stainless steel: Aluminum polish may be used to polish small scratches and scuffs on the finish. Mild soap may be used also to clean the Sidebar.

For gloss black finishes: Mild soap may be used to clean the Sidebar.

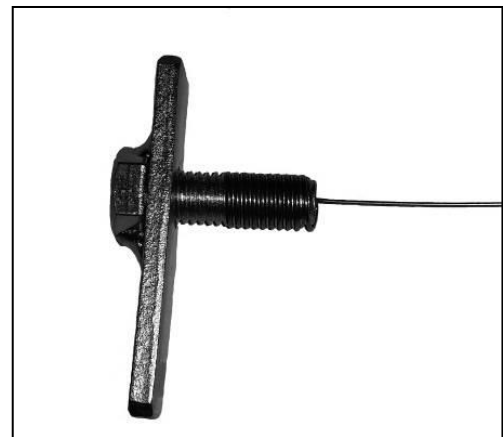
DRIVER SIDE INSTALLATION PICTURED



(Fig 1) Insert coiled end of Fish Wire into the forward oval hole and out through the larger oval hole.

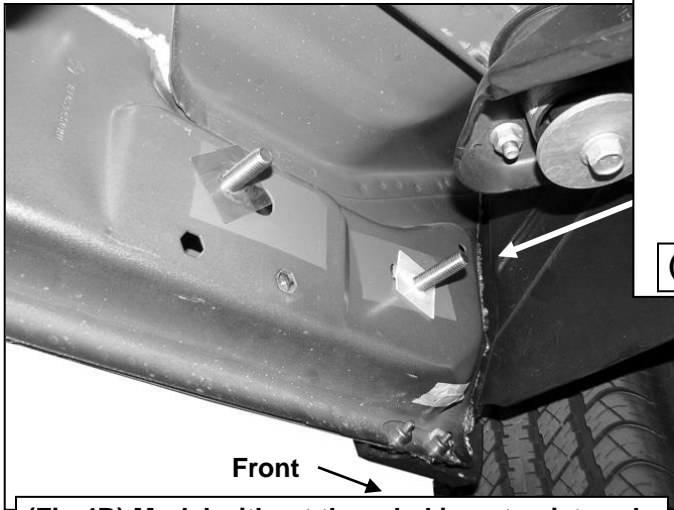


(Fig 3) With the 10mm Bolt Plate attached, slowly pull the Fish Wire back through the forward hole in the body panel. Once completely exposed as pictured, firmly hold the Bolt Plate in place, remove the Fish Wire and thread (1) 10mm Plastic Retainer onto the Bolt Plate to hold it in place (see Fig. 7A),

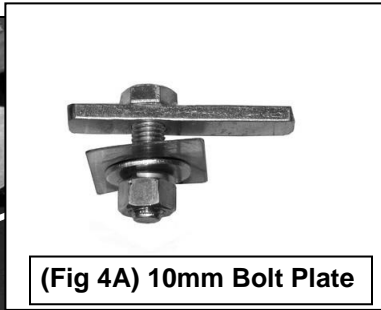


(Fig 2) With Fish Wire as pictured on Figure 1 in body panel, thread 10mm Bolt Plate onto coiled end

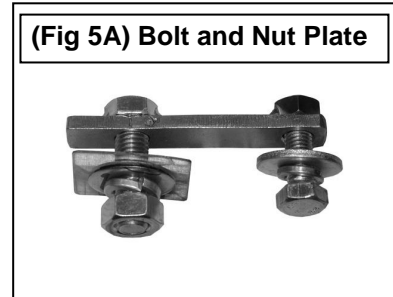
DRIVER SIDE INSTALLATION PICTURED



(Fig 4B) Model without threaded inserts pictured



(Fig 4A) 10mm Bolt Plate



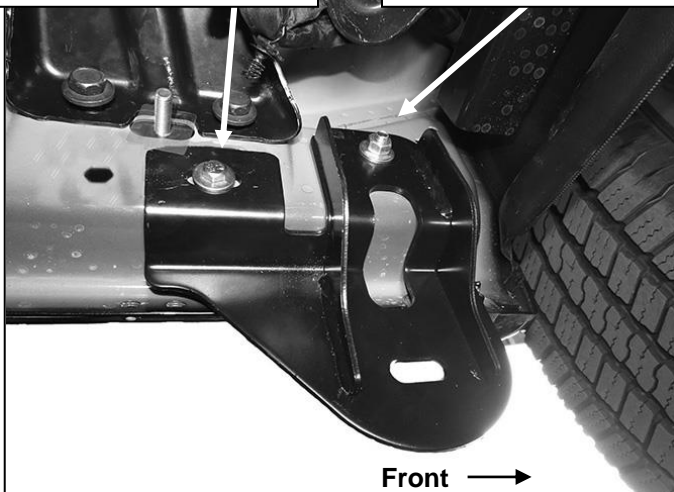
(Fig 5A) Bolt and Nut Plate



(Fig 5B) Models without factory threaded inserts, rotate Bolt and Nut plate to line up Nut with hole in body panel and Bracket

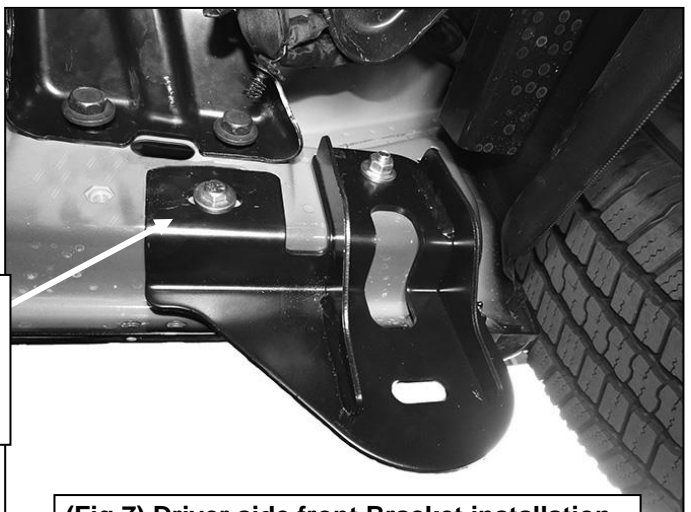
10mm x 35mm Hex Bolt
10mm Lock Washer
10mm Flat Washer

(1) 10mm Flat Washer
(1) 10mm Lock Washer
(1) 10mm Hex Nut



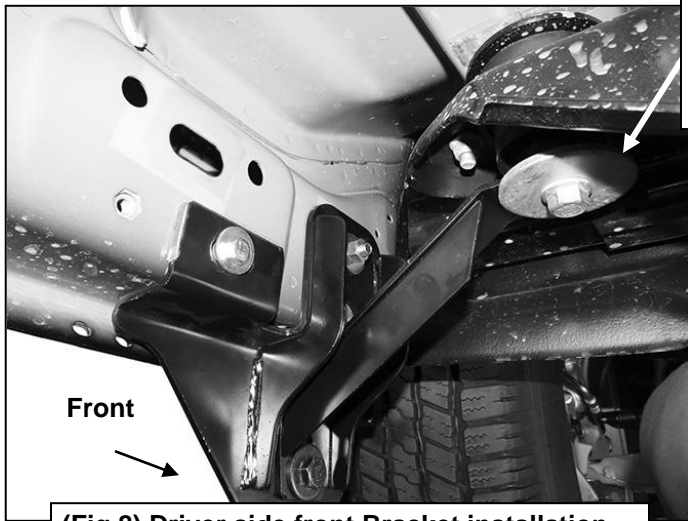
(Fig 6) Models without factory threaded inserts only

8mm x 30mm Hex Bolt
8mm Lock Washer
8mm x 28mm Large Flat Washer
(Bolt/Nut Plate not required on models with threaded inserts)



(Fig 7) Driver side front Bracket installation on model with factory threaded inserts

DRIVER SIDE INSTALLATION PICTURED

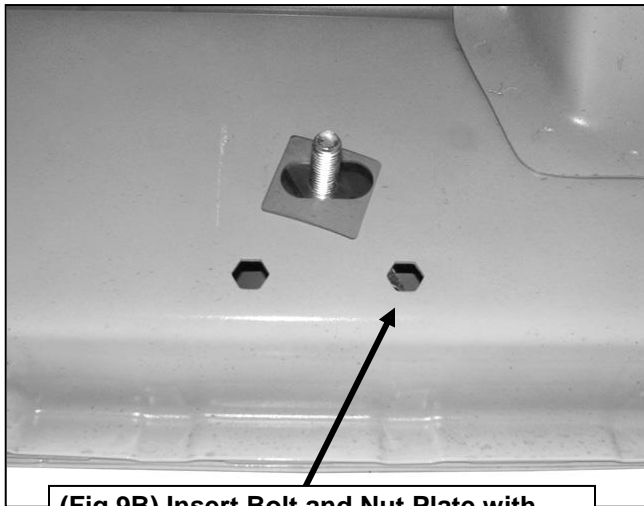


Remove the factory body mount bolt and washer, line up the slot in the driver side Support Bracket and reinstall the factory bolt and washer.

(Fig 8) Driver side front Bracket installation

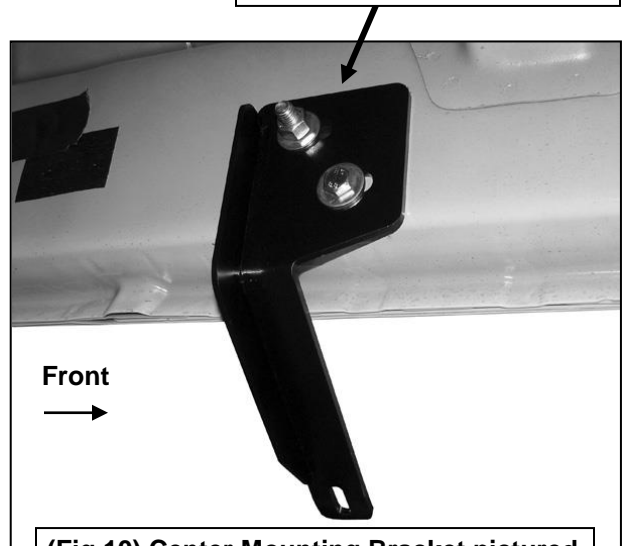


Fig 9A



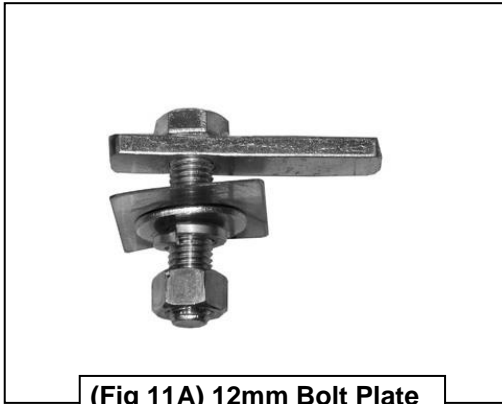
(Fig 9B) Insert Bolt and Nut Plate with Retainer into center location. Rotate Bolt and Nut plate to line up Nut with this hole in body panel and slot in Bracket.

- (1) 12mm Flat Washer
- (1) 12mm Lock Washer
- (1) 12mm Hex Nut
- (1) 10mm x 35mm Hex Bolt
- (1) 10mm Lock Washer
- (1) 10mm Flat washer

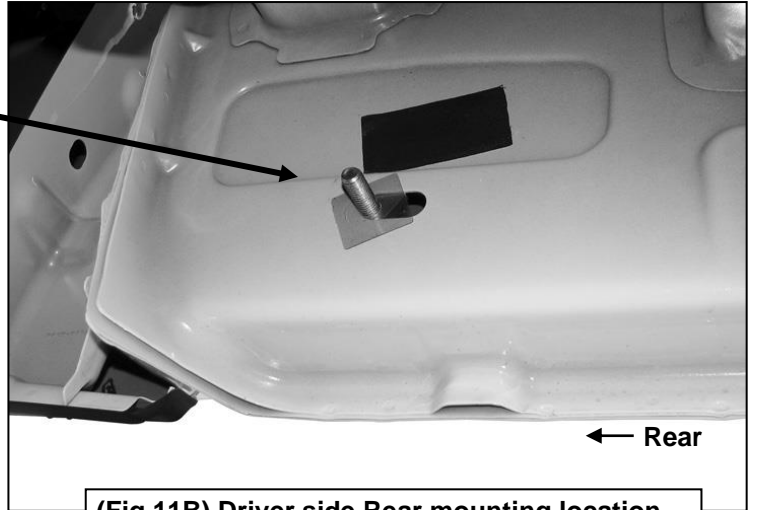


(Fig 10) Center Mounting Bracket pictured

DRIVER SIDE INSTALLATION PICTURED

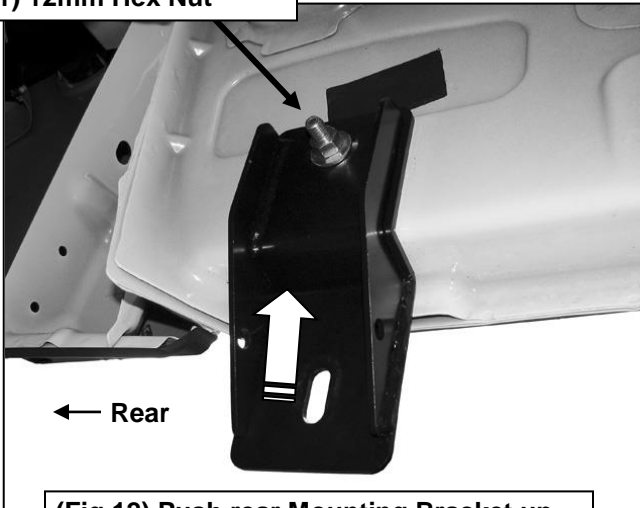


(Fig 11A) 12mm Bolt Plate



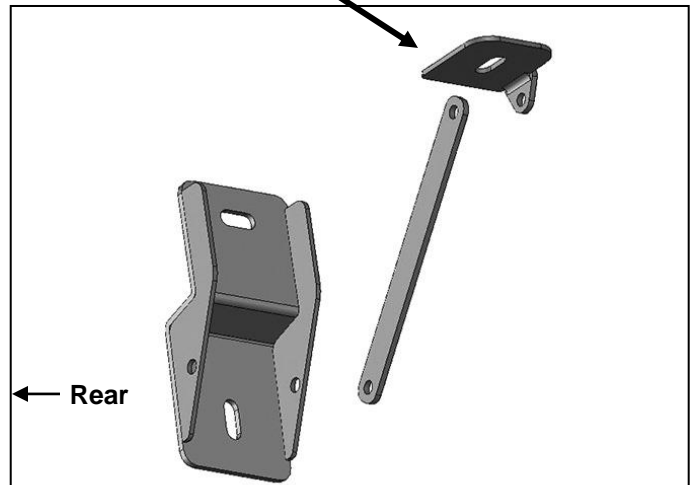
(Fig 11B) Driver side Rear mounting location

- (1) 12mm Flat Washer
- (1) 12mm Lock Washer
- (1) 12mm Hex Nut



(Fig 12) Push rear Mounting Bracket up against the body as you tighten hardware

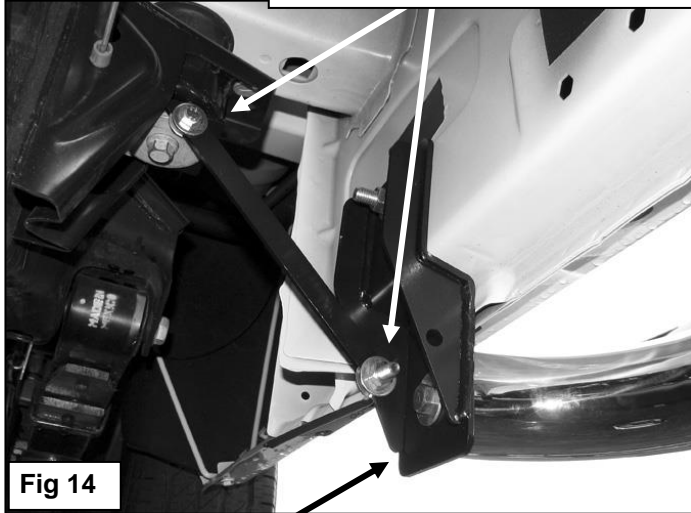
Remove the factory rear body mount bolt and washer. Use the factory body bolt to attach the driver side rear Support Mounting Bracket to the body mount.



(Fig 13) Driver side rear Bracket illustrated

DRIVER SIDE INSTALLATION PICTURED

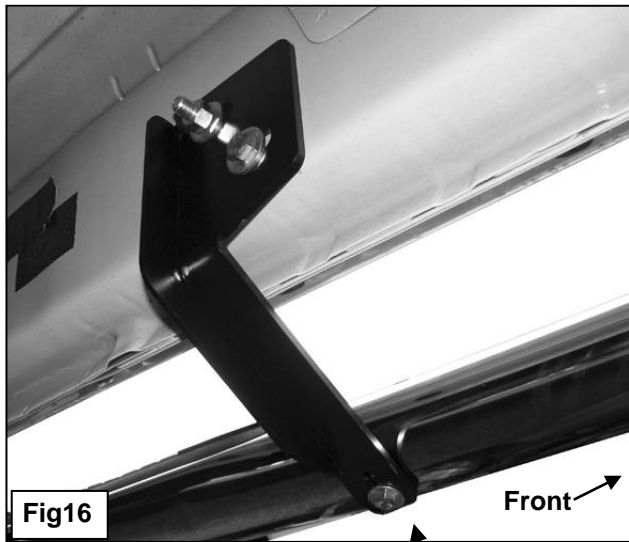
10mm x 35mm Hex Bolt
(2) 10mm x 20mm Flat Washers
10mm Lock Washer
10mm Hex Nut



1/2" x 2" Hex Bolt
1/2" Lock Washer
1/2" Flat Washer



1/2" x 2" Hex Bolt
1/2" Lock Washer
1/2" Flat Washer



8mm x 25mm Hex Bolt
8mm Lock Washer
8mm Flat Washer

