

SIDEBARS WITH 90-DEGREE BENT ENDS
98-01 DODGE RAM 1500 QUAD CAB, 98-02 25-3500 MODELS
94-01 DODGE RAM CLUB CAB, 94-02 25-3500 MODELS

PARTS LIST:

1	Driver/Left Sidebar	8	12mm x 37mm OD x 3mm Flat Washers
1	Passenger/Right Sidebar	4	12mm Lock Washers
2	Front Mounting Brackets	4	10-1.50mm x 35mm Hex Bolts
2	Rear Mounting Brackets	4	10mm Lock Washers
2	Front Support Brackets (short)	8	10mm x 20mm OD x 2mm Flat Washers
2	Rear Support Brackets (long)	4	10mm Hex Nuts
4	Square Bracket Spacers (25 x 23 x 11mm)	4	ST6 x 32mm Self Tapping Sheet Metal Screws
4	12-1.75mm x 120mm Hex Bolts Gr.10.9	4	6mm Lock Washers
4	1/2" x 2" Hex Bolts	4	6mm x 18mm OD x 1.6mm Flat Washers
4	1/2" Lock Washers		

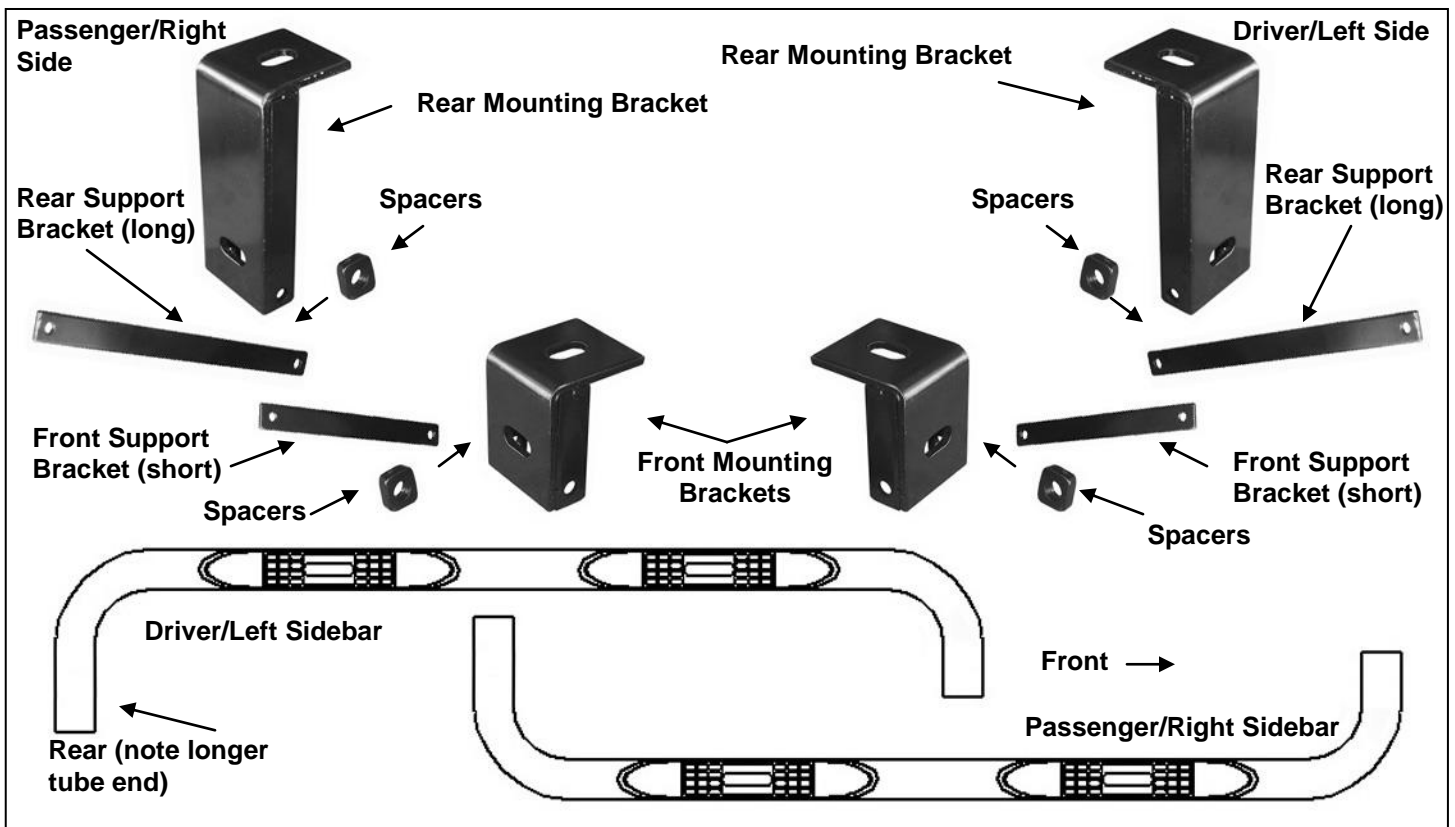

PROCEDURE:

- 1. REMOVE CONTENTS FROM BOX. VERIFY ALL PARTS ARE PRESENT. READ INSTRUCTIONS CAREFULLY BEFORE STARTING INSTALLATION. DRILLING IS REQUIRED.**
- 2. Start the installation under the driver/left side of the vehicle. Remove the factory front body mount bolt, (Figure 1).**

SIDEBARS WITH 90-DEGREE BENT ENDS
98-01 DODGE RAM 1500 QUAD CAB, 98-02 25-3500 MODELS
94-01 DODGE RAM CLUB CAB, 94-02 25-3500 MODELS

3. Select (1) front, (short), Mounting Bracket. Attach the front Bracket to the body mount using the included 12mm x 120mm Hex Bolt, 1/2" Lock Washer and 1/2" Flat Washer, **(Figure 1)**. Leave hardware loose at this time.
4. Repeat **Steps 2 & 3** to install the rear, (long), Mounting Bracket, **(Figure 2)**.
5. Position the Driver Sidebar up to the Mounting Brackets. Attach the Sidebar to the Brackets with the included (2) 1/2" x 2" Hex Bolts, (2) 1/2" Lock Washers and (2) 1/2" Flat Washers, **(Figures 1 & 2)**. **NOTE:** Shorter leg on Sidebar will attach to the front Bracket.
6. Align and adjust the Sidebar to the vehicle and fully tighten all hardware.
7. Select (1) short Front Support Bracket, **(Figure 3A)**. Insert (1) 10mm x 35mm Hex Bolt with (1) 10mm Flat Washer through the larger hole in the Support Bracket. Slide (1) Square Spacer onto the Hex Bolt, **(Figure 3B)**. Secure the Bracket with Spacer to the rear facing side of the front Mounting Bracket with (1) 10mm Flat Washer, (1) 10mm Lock Washer and (1) 10mm Hex Nut, **(Figure 4)**. **IMPORTANT:** Spacers have been provided to space the Support Bracket away from the Sidebar tube, **(Figure 3B)**. Insert the Spacer between the Support Bracket and the Mounting Bracket. The Spacer is designed to push the Support Bracket out to clear the Sidebar tube to prevent rubbing. Use as necessary.
8. Extend the Support Bracket upwards to the body channel. Use the hole in the Support Bracket as a template to mark the drilling location on the body channel, **(Figure 4)**.
9. Once you have marked the location, move the Support Bracket out of the way. Drill a 1/8" pilot hole in the marked location, **(Figure 4)**. The pilot hole is only recommended but not required for the self-drilling Sheet Metal Screws. **IMPORTANT!** Any cutting or drilling tool may break or shatter. Government regulations require safety glasses & equipment at all times when cutting or drilling.
10. Move the Support Bracket back into position and secure to the body channel with the included (1) ST6 x 32mm Sheet Metal Screw, 6mm Lock Washer and (1) 6mm Flat Washer, **(Figure 5)**. Tighten at this time. **IMPORTANT!** Do not over tighten the Screw or pull out may occur.
11. Repeat **Steps 7 – 10** for driver side rear Support Bracket installation, **(Figure 6A)**. **NOTE:** Rear Support Bracket mounts to the front facing side of the rear Mounting Bracket, **(Figure 6B)**.
12. Repeat **Steps 2 – 11** for passenger Sidebar installation.
13. Do periodic inspections to the installation to make sure that all hardware is secure and tight.

To protect your investment, wax this product after installing. Regular waxing is recommended to add a protective layer over the finish. Do not use any type of polish or wax that may contain abrasives that could damage the finish.

For stainless steel: Aluminum polish may be used to polish small scratches and scuffs on the finish. Mild soap may be used also to clean the Sidebar.

For gloss black finishes: Mild soap may be used to clean the Sidebar.

SIDEBARS WITH 90-DEGREE BENT ENDS
98-01 DODGE RAM 1500 QUAD CAB, 98-02 25-3500 MODELS
94-01 DODGE RAM CLUB CAB, 94-02 25-3500 MODELS
Driver Side Installation Pictured

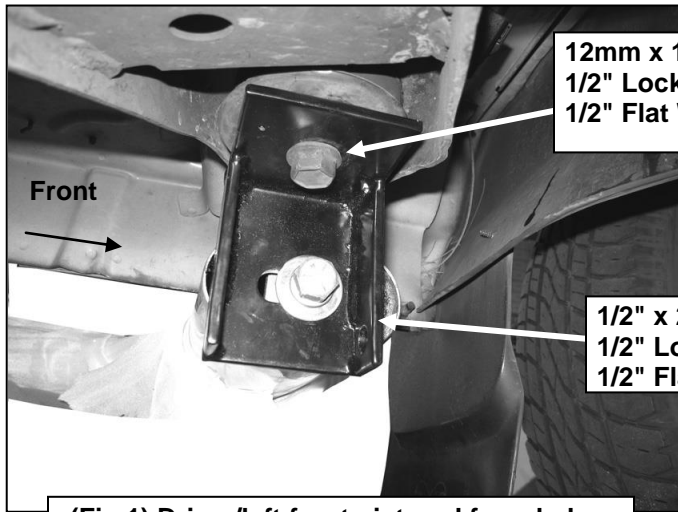

(Fig 1) Driver/left front pictured from below

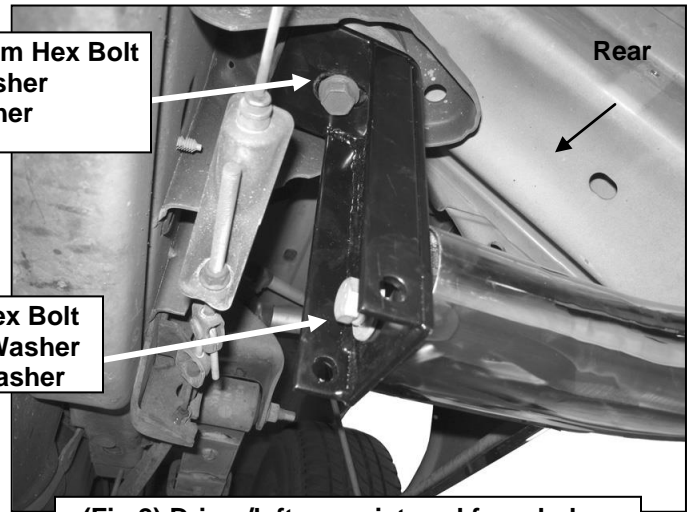

(Fig 2) Driver/left rear pictured from below

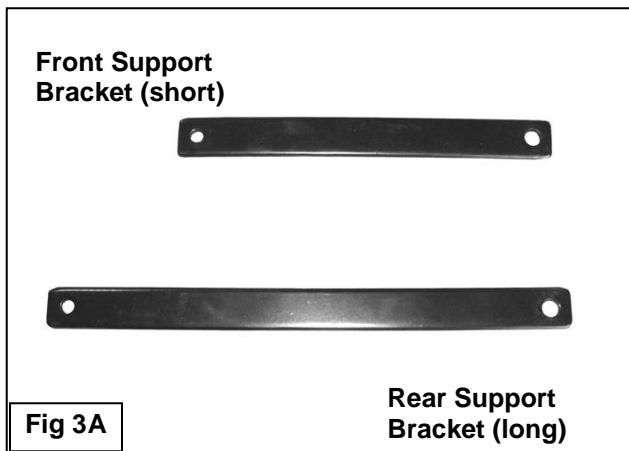
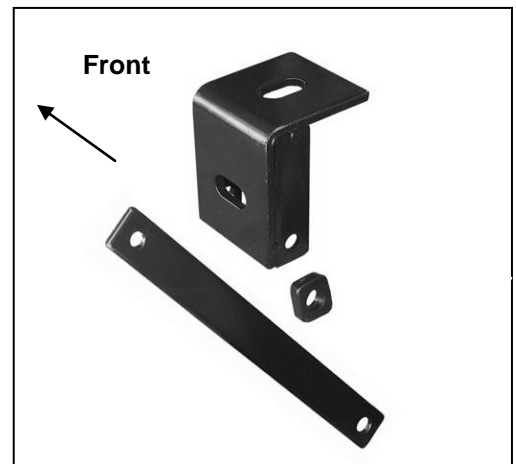

Fig 3A



(Fig 3B) Insert Spacer between Mounting Bracket and Support Bracket

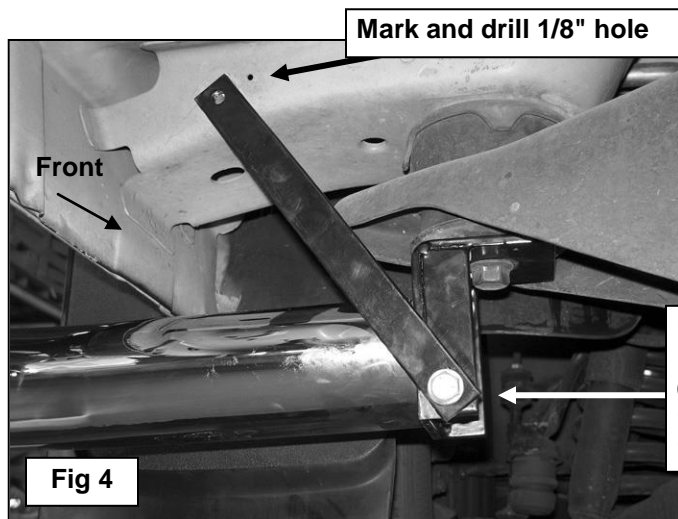

Fig 4

10mm x 35mm Hex Bolt
Bracket Spacer
(2) 10mm Flat Washers
10mm Lock Washer
10mm Hex Nut

SIDEBARS WITH 90-DEGREE BENT ENDS
98-01 DODGE RAM 1500 QUAD CAB, 98-02 25-3500 MODELS
94-01 DODGE RAM CLUB CAB, 94-02 25-3500 MODELS
Driver Side Installation Pictured

