

PARTS LIST:

1	Driver/Left Sidebar	12	10-1.5mm x 25mm Button Head Bolts
1	Passenger/Right Sidebar	4	10mm Split Lock Washers Bracket to Nut Plate)
2	Driver/Left Front or Center Mounting Brackets	12	10mm Inner Tooth Lock Washers (Sidebar to Bracket)
2	Passenger/Right Front or Center Mounting Brackets	4	10mm x 27mm OD x 3mm Flat Washers
1	Driver/Left Rear Mounting Bracket	8	8-1.25mm x 35mm Hex Bolts
1	Passenger/Right Rear Mounting Bracket	8	8mm Split Lock washers
2	10mm Double Nut Plates	8	8mm x 28mm OD x 3mm Flat Washers
4	10-1.5mm x 40mm Hex Bolts	1	6mm Allen Wrench

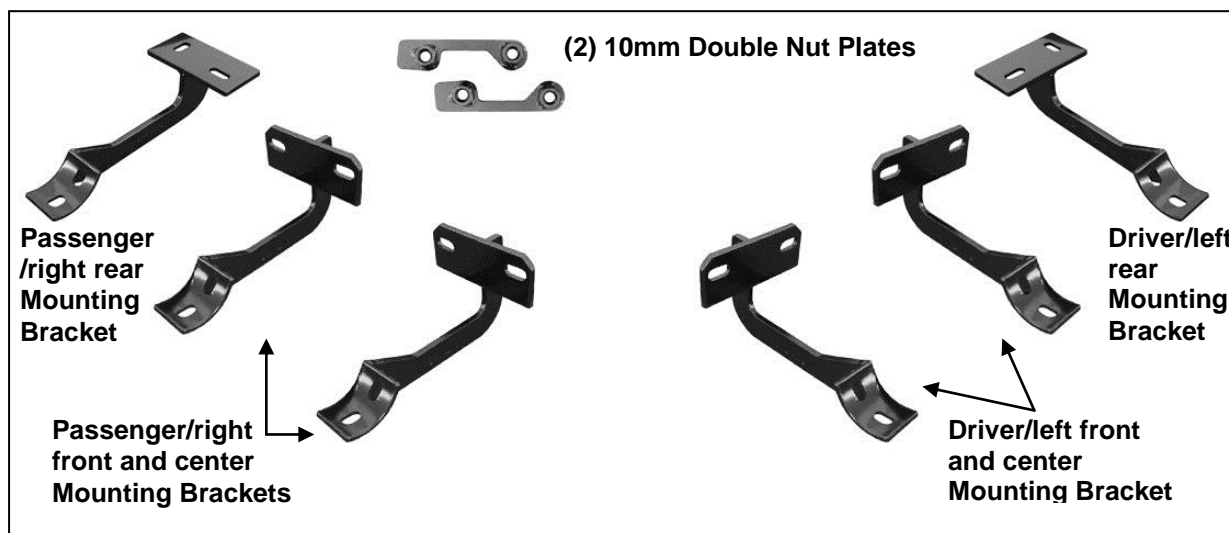

PROCEDURE:

- 1. REMOVE CONTENTS FROM BOX. VERIFY ALL PARTS ARE PRESENT. READ INSTRUCTIONS CAREFULLY BEFORE STARTING INSTALLATION.**
- Starting the installation at the driver side-left front, locate the (2) factory 8mm threaded holes in the inner body panel, **(Figures 1 & 3)**. **NOTE:** Holes may be covered with plugs or undercoating. Select (1) Driver side front or center Bracket (same). Bolt the Bracket to the (2) threaded holes with (2) 8mm x 35mm Hex Bolts, (2) 8mm Lock washers and (2) 8mm Flat Washers. Leave hardware loose at this time.
- Repeat Step 2 for driver side Center Bracket installation, **(Figure 3)**.
- Move toward the rear of the vehicle. Locate the oval and round hole in bottom of the floor panel. Insert (1) 10mm Double Nut Plate into the oval hole. Line up the threaded nuts with the round and oval holes, **(Figures 2 & 3)**. **NOTE:** Nut Plate must be flat against the inside of the body panel with the Welded nuts on top.
- Select the driver side Rear Bracket. Bolt the Bracket to the Nut Plate with (2) 10mm x 40mm Hex Bolts, (2) 10mm Split Lock Washers and (2) 10mm Flat Washers, **(Figures 2 & 3)**. Do not tighten hardware at this time.
- Carefully position the driver Sidebar onto the Mounting Brackets and secure using (6) 10mm x 25mm Button Head Bolts and (6) 10mm Internal Lock Washers, **(Figure 3)**. Snug but do not tighten hardware at this time.

7. Adjust and level the Sidebar and tighten all hardware.
8. Repeat **Steps 2 - 7** for passenger/right Sidebar installation.
9. Do periodic inspections to the installation to make sure that all hardware is secure and tight.

To protect your investment, wax this product after installing. Regular waxing is recommended to add a protective layer over the finish. Do not use any type of polish or wax that may contain abrasives that could damage the finish.

For stainless steel: Aluminum polish may be used to polish small scratches and scuffs on the finish. Mild soap may be used also to clean the Sidebar.

For gloss black finishes: Mild soap may be used to clean the Sidebar.

Driver Side Installation Pictured

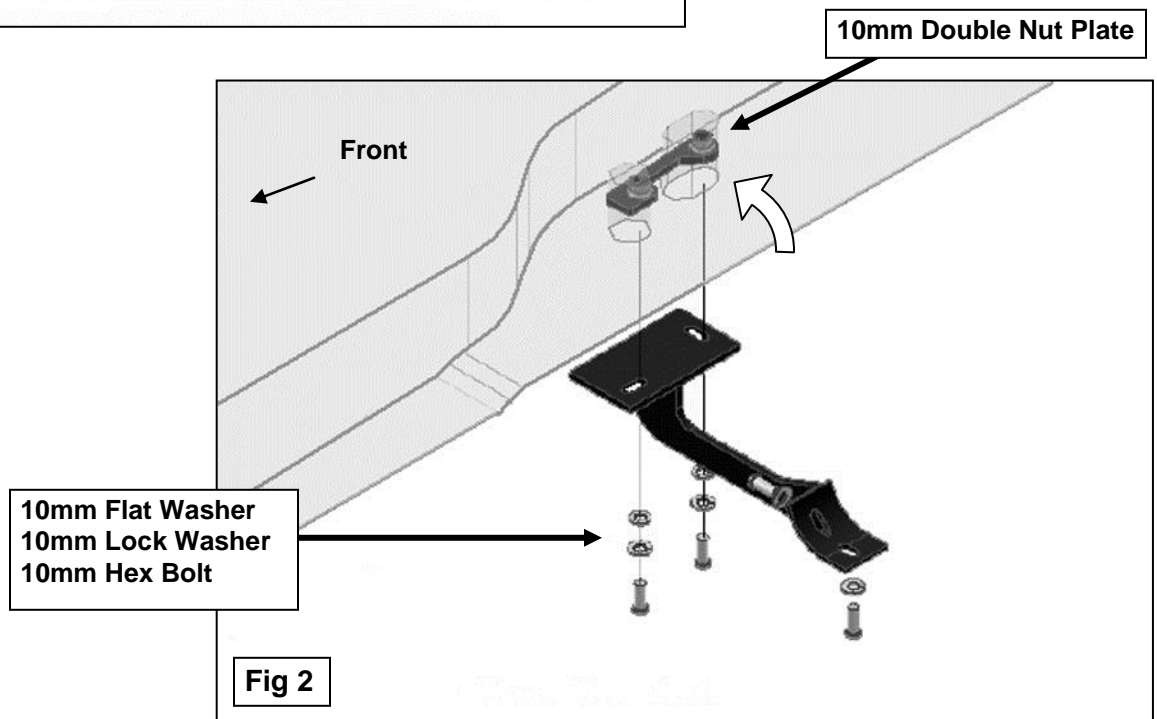
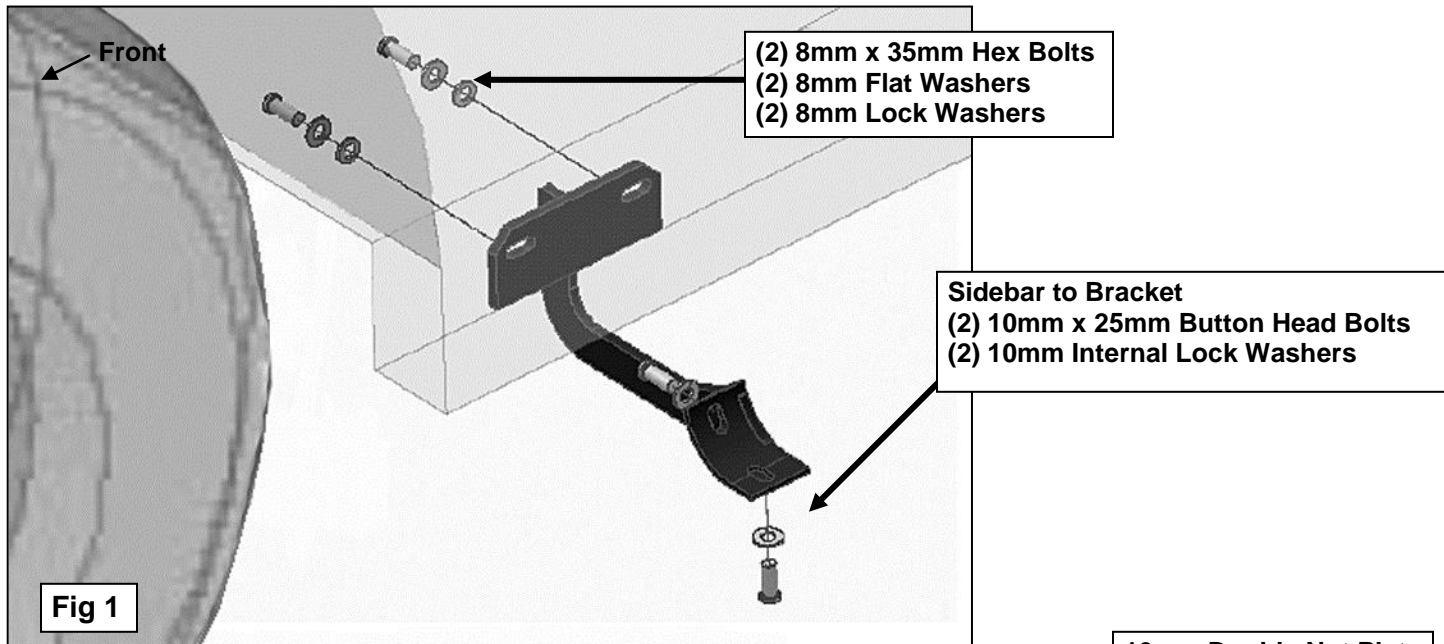

Driver Side Installation Pictured

