

INSTALLATION INSTRUCTIONS
3" & 4" 90DEG BENT END SIDEBARS
04-08 F-150 REGULAR CAB, SUPER CAB, SUPER CREW CAB
PART NUMBER #

PARTS LIST:

Qty	Description	Qty	Description
1	Driver/Left Sidebar	4	10mm Clip Nuts
1	Passenger/Right Sidebar	6	12mm x 30.1mm OD x 3.1mm Flat Washers
1	Driver/Left front Mounting Bracket	6	12mm Lock Washers
1	Passenger/Right front Mounting Bracket	6	12mm Hex Nuts
1	Driver/Left rear Mounting Bracket	4	10-1.50mm x 35mm Hex Bolts
1	Passenger/Right rear Mounting Bracket	4	10mm x 30mm OD x 3mm Flat Washers
4	1/2" x 2" Hex Bolts	4	10mm Lock Washers
4	1/2" x 1-1/4" x 3/32" Flat Washers	8	8-1.25mm x 30mm Hex Bolts
4	1/2" Lock Washers	16	8mm x 25.5mm OD x 3mm Flat Washers
2	12mm X 35mm single bolt plates	8	8mm Lock Washers
2	12mm X 40mm double bolt plates	8	8mm Hex Nuts
4	11mm plastic retainers		

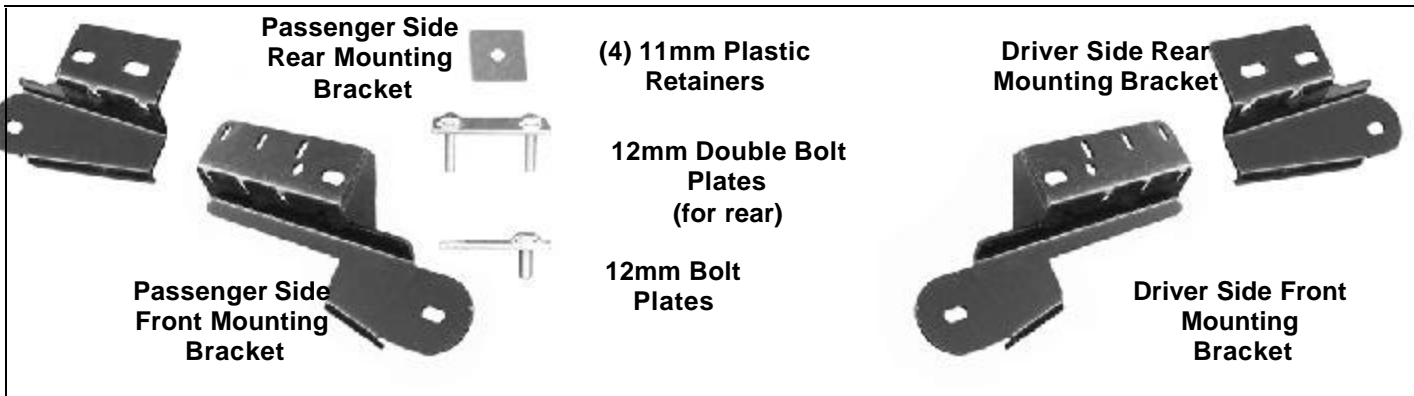

PROCEDURE:

- 1. REMOVE CONTENTS FROM BOX. VERIFY ALL PARTS ARE PRESENT. READ INSTRUCTIONS CAREFULLY BEFORE STARTING INSTALLATION.**
- Starting at the passenger side-front of the vehicle, locate the round and rectangular openings in the inner body panel. **NOTE:** Mounting holes may be covered with rubber plugs and/or sealing tape. Remove to uncover mounting locations. Insert (2) 10mm Clip Nuts (with the nut portion to the inside) into the rectangular opening and line up the threaded nut with the factory round holes, **(Figure 1)**. Next, partially thread (1) 11mm Plastic Retainer onto (1) 12mm Bolt Plate, **(Figure 2)**, and insert the Bolt Plate into the large round hole. Once inserted, thread the Plastic Retainer onto the threaded end of the Bolt Plate until it is flush against the body panel. **NOTE:** When properly installed, the

Plastic Retainer is designed to prevent the Bolt Plate from falling into the body cavity during Bracket installation.

3. Locate the driver side front Mounting Bracket. Attach the Mounting Bracket to the Bolt Plate with (1) 12mm Flat Washer, (1) 12mm Lock Washer and (1) 12mm Hex Nut. Do not tighten hardware at this time. Line up the two holes in the Mounting Bracket with the previously installed Nut Clips and secure with (2) 10mm Hex Bolts, (2) 10mm Flat Washers and (2) 10mm Lock Washers. Do not tighten hardware at this time. Next, line up the two holes in the front Mounting Bracket with the factory holes in the pinch weld. Attach the Mounting Bracket to the pinch weld using the included (2) 8mm x 30mm Hex Head Bolts, (2) 8mm Lock Washers, (4) 8mm Flat Washers and (2) 8mm Hex Nuts, **(Figure 3)**. **NOTE:** Insert the Bolt with the Flat Washer up, from the outside-in. Snug all hardware but do not tighten at this time.
4. Moving to the rear, locate the factory large round hole and smaller oval hole in the inner body panel. **NOTE:** Mounting holes may be covered with sealing tape, **(Figure 4)**. Remove tape to uncover mounting locations. Select (1) 12mm Double Bolt Plate and insert it into the larger round opening and out the smaller oval hole. Next, thread (1) 11mm Plastic Retainer onto the threaded end so that the retainer covers the smaller of the two holes, **(Figure 5)**. Thread the Retainer all of the way down to the sheet metal. **NOTE:** When properly installed, the Plastic Retainer is designed to prevent the Bolt Plate from falling into the body cavity during installation.
5. Select the passenger side Rear Mounting Bracket and attach it to the Double Bolt Plate with (2) 12mm Flat Washers, (2) 12mm Lock Washers and (2) 12mm Hex Nuts, **(Figure 6)**. Snug all hardware but do not tighten at this time.
6. Once the Mounting Brackets are partially mounted, carefully unpack and separate the driver and passenger Sidebars. Position the passenger Sidebar onto the Mounting Brackets using the included (2) 1/2" x 2" Hex Head Bolts, (2) 1/2" Lock Washers, and (2) 1/2" Flat Washers. Snug but do not tighten at this time.

Optional Mounting Method, drilling is required: In addition to the Double Bolt Plate, the rear Mounting Bracket also has two additional slots that may be used to bolt the Bracket to the pinch weld, (similar to the front Mounting Bracket in Step 3). This step requires drilling two 3/8" holes through the pinch weld after the Mounting Bracket has been properly lined up with the Sidebar.

A. Before drilling, unpack the Passenger Sidebar and move the Mounting Brackets into the proper position in alignment with the Sidebar. Tighten the rear Mounting Bracket hardware.

B. Use the Mounting Bracket as a drill template and drill two 3/8" holes down through the open slots in the Bracket and through the pinch weld. Attach the Mounting Bracket to the pinch weld using the included (2) 8mm x 30mm Hex Head Bolts, (2) 8mm Lock Washers, (4) 8mm Flat Washers and (2) 8mm Hex Nuts.

NOTE: Insert the Hex Bolt with the Flat Washer up from the outside-in.

This step is an option only and not required for typical installation.

7. Level and adjust Sidebar and tighten all hardware.
8. Repeat steps 2 – 7 for passenger Sidebar.
9. Do periodic inspections of the installation to make sure all hardware is secure and tight.

To protect your investment, wax this product after installing. Regular waxing is recommended to add a protective layer over the finish. Do not use any type of polish or wax that may contain abrasives that could damage the finish.

For stainless steel: Aluminum polish may be used to polish small scratches and scuffs on the finish. Mild soap may be used also to clean the Sidebar.

For gloss black finishes: Mild soap may be used to clean the Sidebars.

PASSENGER SIDE INSTALLATION PICTURED

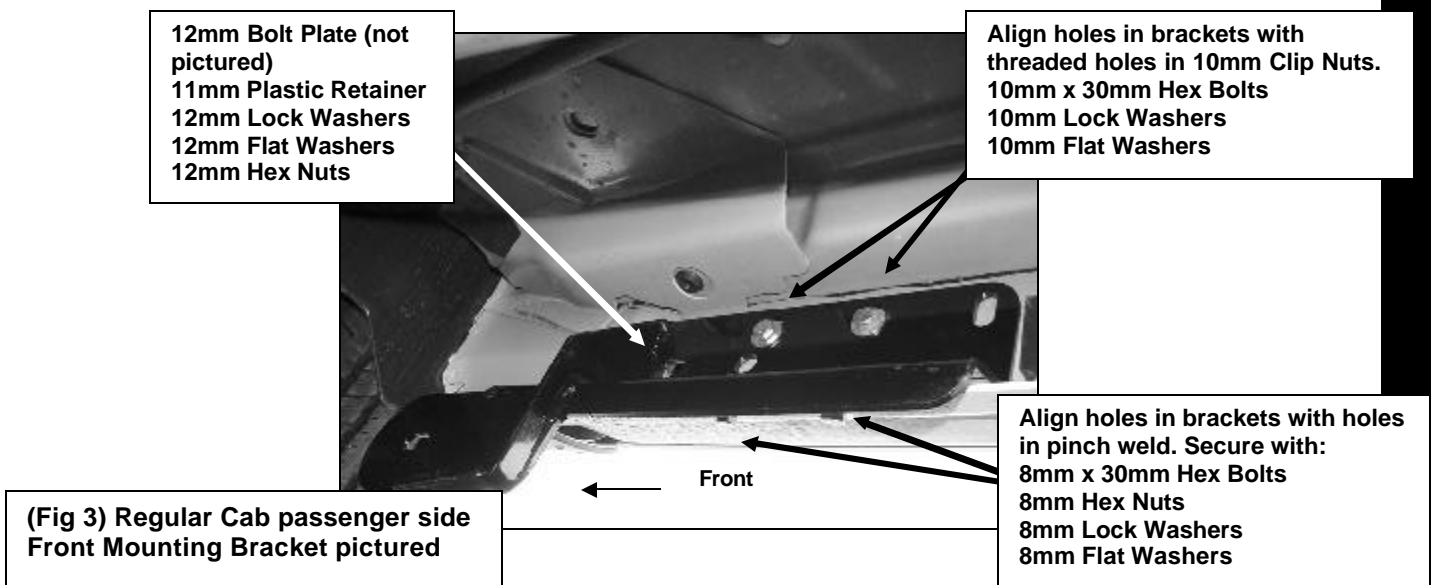
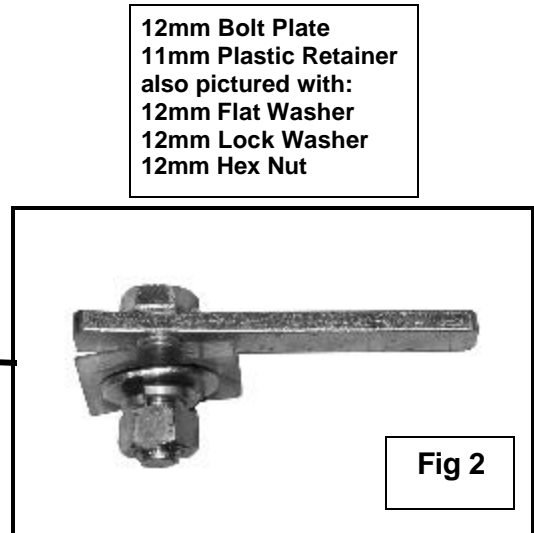
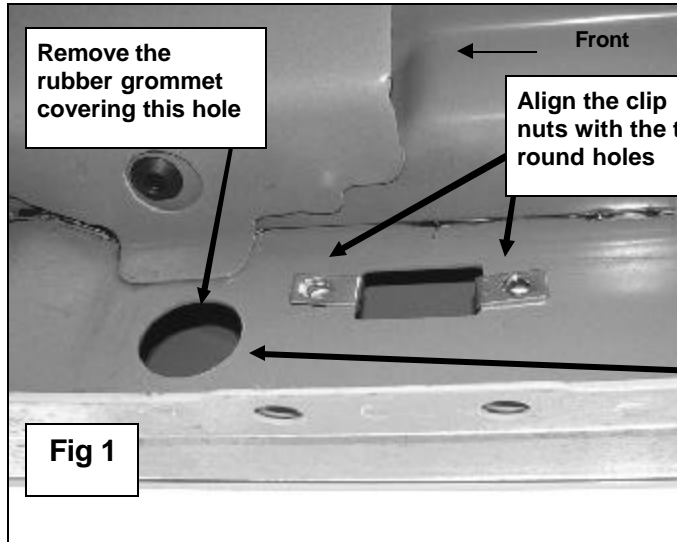

(Fig 3) Super Cab and Super Crew Cab passenger side Front Mounting Bracket pictured

Align holes in brackets with holes in pinch weld. Secure with:
8mm x 30mm Hex Bolts
8mm Hex Nuts
8mm Lock Washers
8mm Flat Washers

PASSENGER SIDE INSTALLATION PICTURED

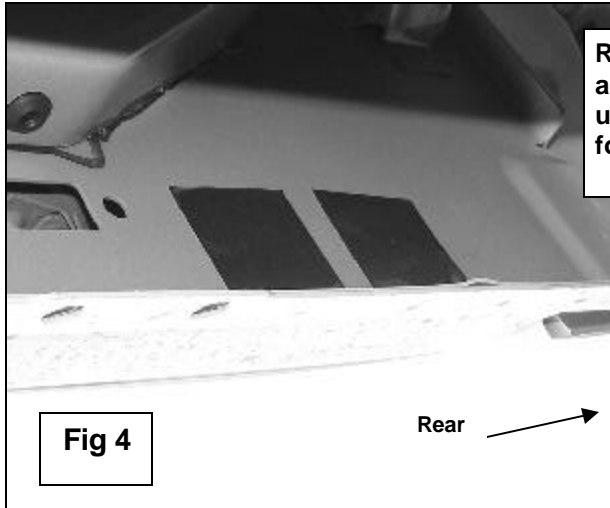

Remove sealing tape and/or rubber grommets to uncover the rear location for the Mounting Brackets

Insert the 12mm Double Bolt Plate into the large round hole and back out the oval hole. Thread the 11mm Plastic Retainer onto the threaded end and cover the oval hole. Secure the Rear Mounting Bracket to the Bolt Plate with:
2) 12mm Flat Washers
2) 12mm Lock Washers
2) 12mm Hex Nuts

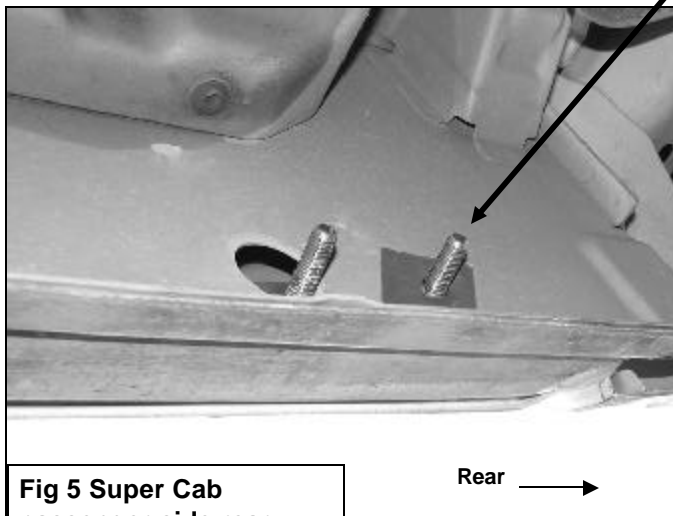

Fig 5 Super Cab passenger side rear mounting location pictured. Shown with Plastic Retainer in place

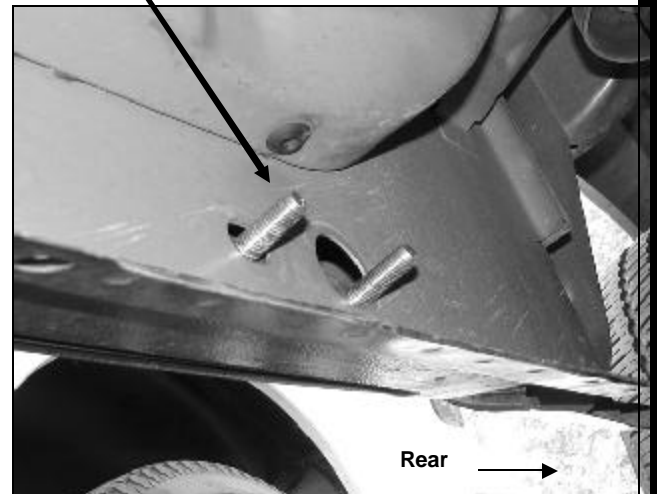

Fig 5 Regular Cab and Super Crew Cab passenger side rear mounting location pictured

2) 12mm Flat Washers
2) 12mm Lock Washers
2) 12mm Hex Nuts

Secure the Sidebar to the Mounting Brackets with:
2) 1/2" x 2" Hex Bolts
2) 1/2" Flat Washers
2) 1/2" Lock Washers