

INSTALLATION INSTRUCTIONS

SIDE BAR

80-96 FORD F-SERIES REGULAR CAB

PART #

ITEM	QTY	CONTENTS TOOLS	
1	2	STEP BARS - DRIVER/PASSENGER (PINK SLEEVE)	3/4" SOCKET
2	2	FRONT MOUNTING BRACKETS - DF/PF	3/4" WRENCH
3	2	REAR MOUNTING BRACKETS - DR/PR	11/16" SOCKET
4	2	REAR SWING BRACKET	11/16" WRENCH ADJUSTABLE WRENCH
5	2	REAR HANGER BRACKET	RATCHET
6	2	SPACER TUBE	TORQUE WRENCH
7	4	1/2-13 X 2.00" HEX HEAD BOLT	
8	2	1/2-13 X 1.50" HEX HEAD BOLT	
9	6	1/2" FLAT WASHER	
10	6	1/2" LOCK WASHER	
11	2	1/2-13 HEX NUT	
12	2	7/16-14 X 1.75" HEX HEAD BOLT	
13	2	7/16-20 X 1.75" HEX HEAD BOLT	
14	2	7/16-14 X 1.75" COUPLING NUT	
15	2	7/16-20 X 1.75" COUPLING NUT	
16	4	M12 LOCK WASHER	
17	4	M10*25 HEX HEAD BOLT	
18	2	M10 LOCK WASHER	
19	2	PLASTIC WASHER	

PRODUCT INSTALLATION:

- 1 Verify all parts & hardware are present. Read Instruction Sheets before installing.
- 2 Screw 7/16-14 x 1.75" Coupling nut onto front body mount and torque to 40 Ft/lbs. Attach front bracket to body mount as shown. NOTE: Do not tighten at this time. Attach short end of step bar to front bracket. SEE FIGURE 1, 3
- 3 Attach rear bracket onto bottom flange of vehicle frame and attach rear swing bracket to rear bracket. Do not tighten. Attach rear leg of tube to rear swing bracket as shown. Adjust tube and brackets until rear leg of tube is level with front end of step bar. Tighten rear swing bracket to rear bracket and secure rear bracket to frame with M10*25 hex head bolt/M10 washer/lock washer. SEE FIGURE 2, 3
- 4 Screw 7/16-20 x 1.75" coupling nut onto bolt above the hole in step bar tube. Torque to 40 Ft/lbs. Attach rear hanger bracket to coupling nut as shown in the position to line up with the hole in tube. Sight level tube and attach hanger bracket to tube using one of the two holes in the hanger bracket and placing a rubber washer between the hanger bracket and step bar tube. Torque M10*25" hex bolt to 20 Ft/lbs.

SEE FIGURE 2, 3

- 1 Torque 1/2" fasteners to 65 Ft/lbs. and 7/16" fasteners to 40 Ft/lbs.
- 2 After all the bolts/flat washers/lock washers/hex nuts have been installed, make sure that all fasteners have been tightened.

**SIDE BAR
80-96 FORD F-SERIES REGULAR CAB**

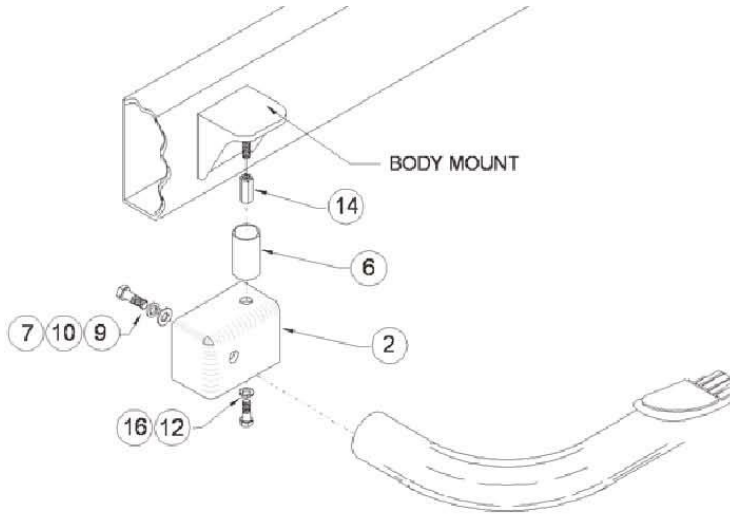

FIGURE 1 - DRIVER-FRONT

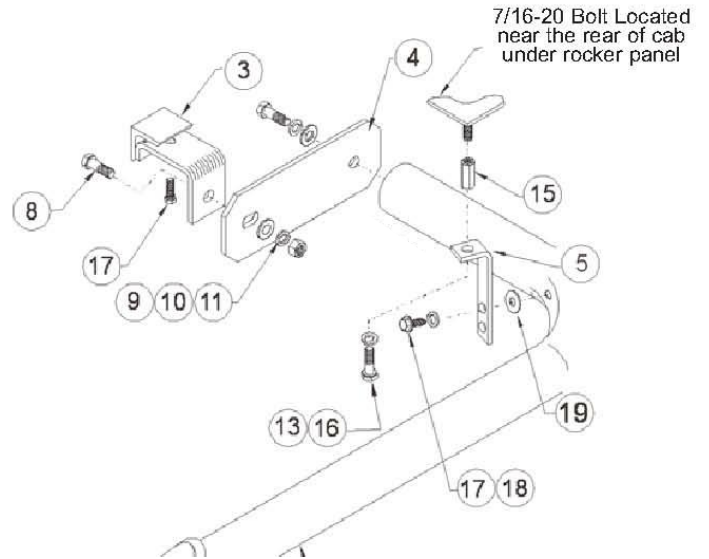
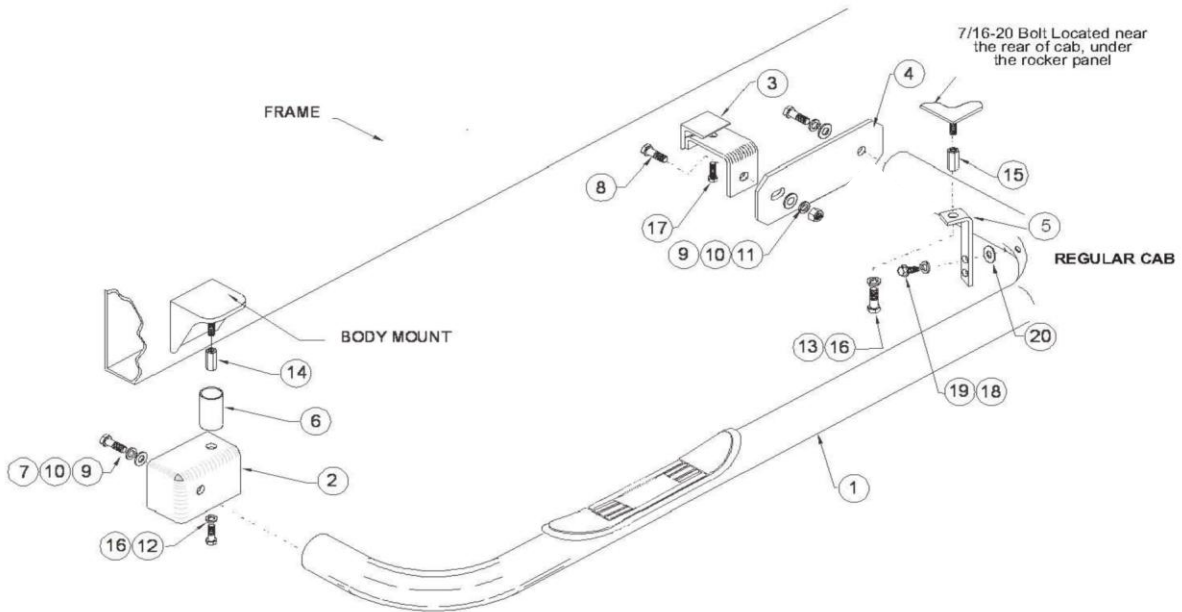

FIGURE 2 - DRIVER-REAR



INSTALLATION VIEW OF DRIVER SIDE SHOWN, PASSENGER SIDE OPPOSITE