

INSTALLATION INSTRUCTIONS

SIDEBAR

88-98 CHEVY/GMC C/K P/U EXTENDED CAB

PART NUMBER 200110 / 200117

PARTS LIST:

2	Front Mounting Brackets – small	4	12-1.75mm x 110mm Hex Head Bolts
2	Rear Mounting Brackets – large	2	10-1.50mm x 32mm Hex Head Bolts
2	Support Brackets	2	10mm Lock Washers
4	½" x 2" Hex Head Bolt	4	10mm Flat Washers
8	12mm Lock Washers	2	10mm Hex Nuts
8	12mm Flat Washers	4	3" Plastic Rings

PROCEDURE:

1. REMOVE CONTENTS FROM BOX. VERIFY ALL PARTS ARE PRESENT. READ INSTRUCTIONS CAREFULLY BEFORE STARTING INSTALLATION.
2. Remove the four body mounts.
3. Attach the front and rear Mounting Brackets to the body mounts with the 12mm x 110mm Hex Head Bolts, 12mm Lock Washers, and 12mm Flat Washers as shown in the drawing, and hand tighten.
4. Place the Sidebars into position.
5. Attach the Sidebars to the Mounting Brackets with the ½" x 2" Hex Head Bolts, 12mm Lock Washers, and 12mm Flat Washers. Place a 3" Plastic Ring between the Sidebar and the Mounting Brackets then hand tighten.
6. Remove the previously installed 12mm x 50mm Hex Head Bolts holding the end of the Sidebar to the rear Mounting Bracket. Put the short end of the Support Bracket up to the backside of the rear Mounting Bracket and attach it with the 12mm hardware previously removed. Orient the Support Bracket so that the long end touches the bottom of the frame. Using the hole in the long end as a guide, drill a 7/16" hole in the bottom of the frame and attach it with the 10mm hardware provided.
7. After checking to make sure the Sidebars are level and square with the side of the vehicle completely tighten all hardware.
8. Periodically check and retighten the hardware as necessary.

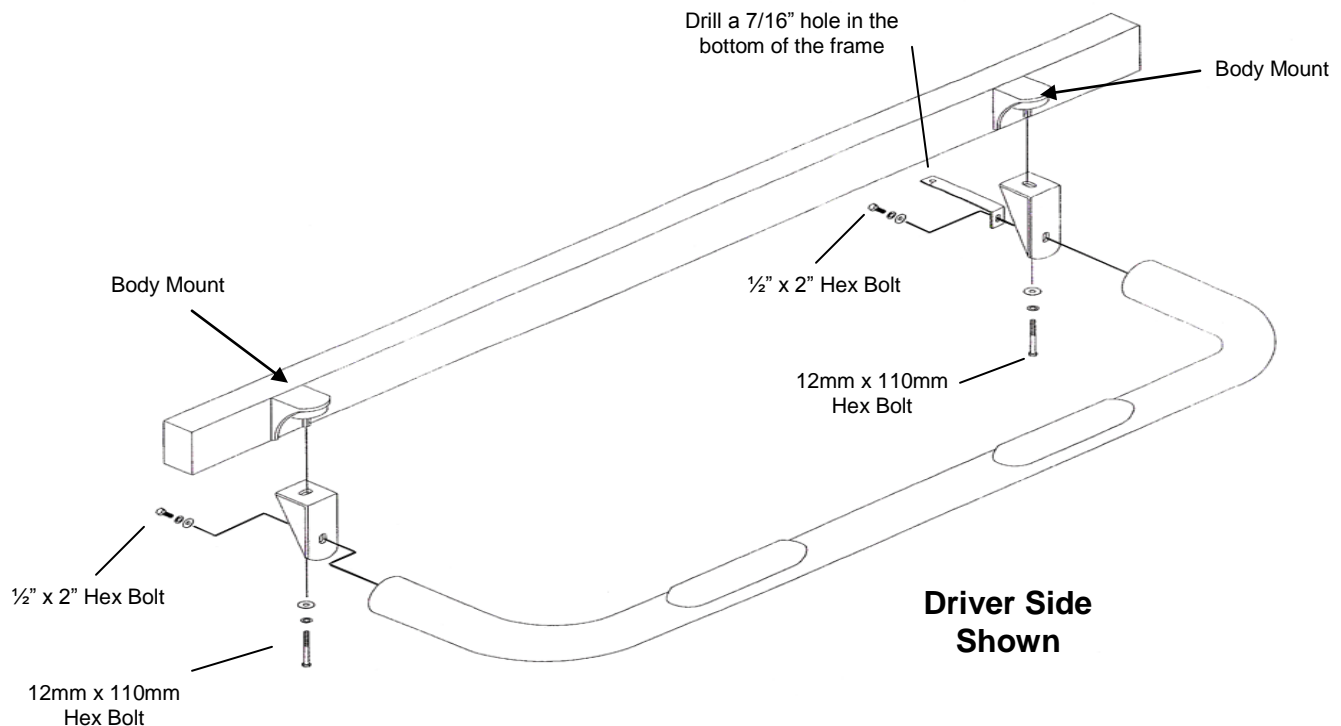

IMPORTANT ALERT: GM uses a very strong thread-locking compound on all body bolts. Use of an air assisted impact ratchet can cause damage to the threads on factory body mount bolts and the internal nut assembly because of this thread locking compound. We only recommend the use of hand tools to slowly remove and reinstall body mount bolts on all GM vehicles.

PROCEDURE:

CRITICAL INFORMATION: If during the removal process, it becomes increasingly difficult to unscrew the body mount bolt with hand tools, tighten the bolt several rotations to clear the thread locking compound from the threads, then reverse direction and continue to unscrew until the body mount bolt is out. Repeat this process as necessary on all GM body mount bolts. Use of an appropriate anti-seize compound is highly recommended for re-installation. Tighten body mount bolt to factory torque specifications for your particular model year.

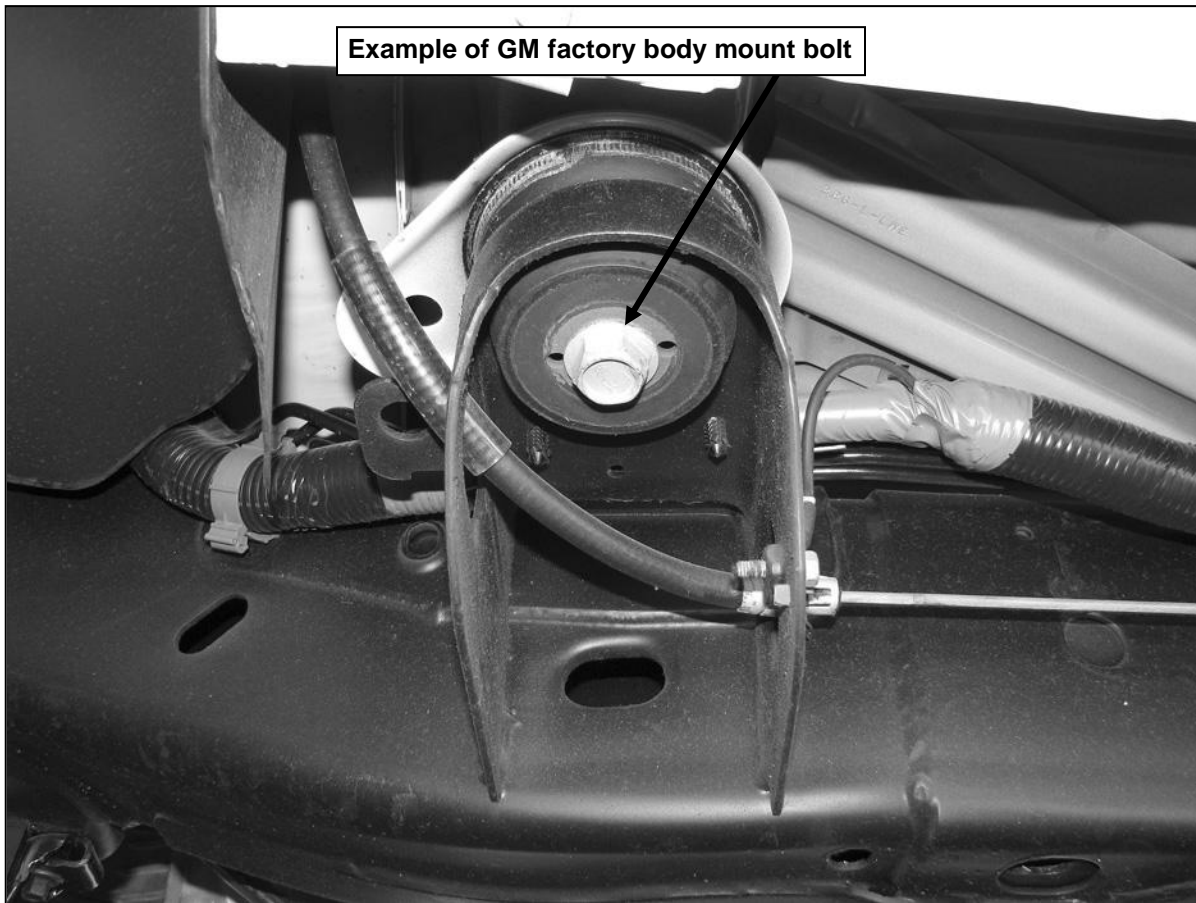

Example of GM factory body mount bolt