

**HD REAR BUMPER
2016-17 TITAN "XD" AND 2017 TITAN MODELS**

PARTS LIST:

1	HD Replacement Rear Bumper	4	12mm x 40mm Hex Bolts
1	Driver/Left Bracket	4	12mm Nylon Lock Nuts
1	Passenger/Right Bracket	8	12mm x 37mm x 3mm Oversize Flat Washers
2	Thin Side Spacers	4	Rubber Sensor Plugs
2	Thick Bottom Spacers (w-o hitch only)	1	Allen Wrench S=2.5
1	License Plate Light	8	4mm x 10mm Button Head Screws
2	Plastic License Plate Plugs	1	Sensor Cover Kit

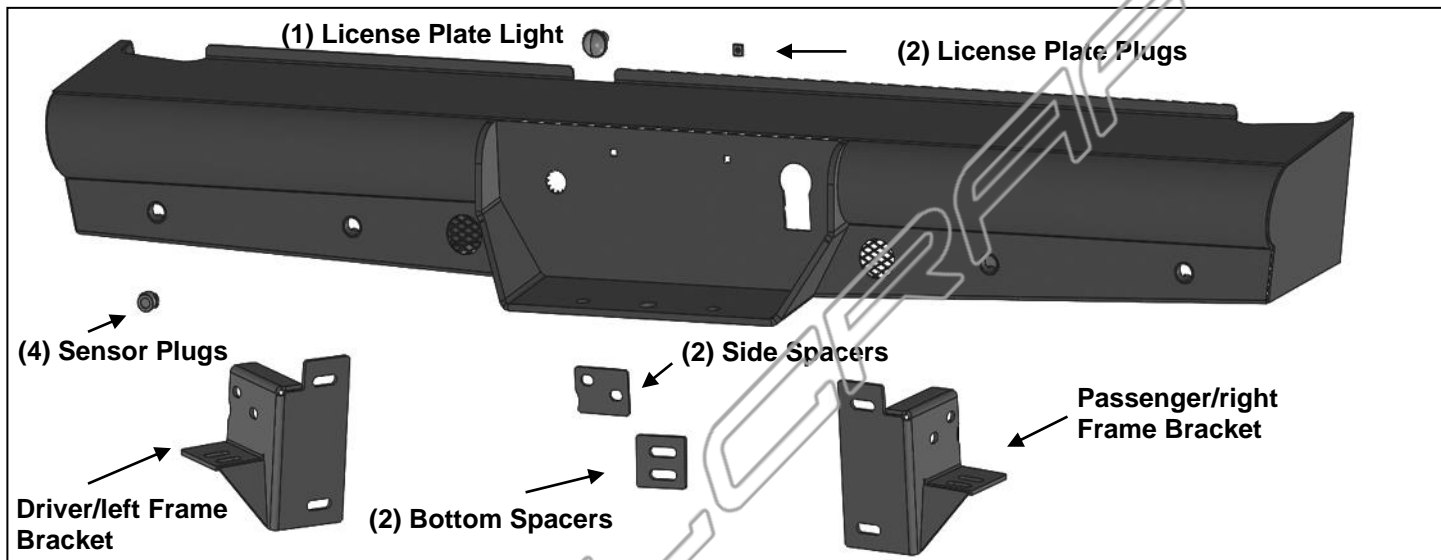

PROCEDURE:

REMOVE CONTENTS FROM BOX. VERIFY ALL PARTS ARE PRESENT. READ INSTRUCTIONS CAREFULLY BEFORE STARTING INSTALLATION. BUMPER IS HEAVY, ASSISTANCE IS HIGHLY RECOMMENDED TO AVOID POSSIBLE INJURY OR DAMAGE TO THE VEHICLE. BLIND SPOT WARNING SENSORS IN SIDES OF REAR BUMPER MUST BE REMOVED AND CANNOT BE REINSTALLED.

1. Begin by verifying if your truck is equipped with Blind Spot Warning (BSW). This replacement bumper is not compatible with this technology and you will need to disable the program in the dashboard computer before disconnecting unit.
2. Start installation by unplugging the towing harness plug and sensors if equipped, **(Figure 1)**. Move the wiring harness away from the bumper. Remove the license plate and towing harness plug from the bumper.
3. Place blocks or jack stands under the bumper to support it during bumper bolt removal. From under the bumper, release the clips attaching the top cover to the bumper. Remove the plastic cover from the top of the bumper **(Figure 2)**.
4. Next, remove the factory Torx head bumper bolts from the bottom of the bumper, **(Figure 1)**. Remove the top mounting bolts attaching the bumper to the top of the hitch if equipped or inner bumper reinforcement and slide the bumper off of the end of the frame, **(Figures 3 & 4)**.
WARNING! Assistance is required to hold the bumper in place during hardware removal and to prevent the bumper from falling. **NOTE:** If preferred, bumper and hitch or reinforcement can all be removed as an assembly then separated off the vehicle.
5. Select the passenger/right Frame Bracket. Determine correct installation for your vehicle.
Models without factory receiver hitch
 - a. Remove the bumper reinforcement from the ends of the frame.
 - b. Hold the Passenger/right Mounting Bracket up to the bottom of the frame. Slide (1) Bottom Spacer Plate between the Bracket and the bottom of the frame, **(Figure 5)**.

**HD REAR BUMPER
2016-17 TITAN "XD" AND 2017 TITAN MODELS**

Reuse the (2) factory bolts to attach the Bracket and Spacer to the bottom of the frame, **(Figures 5 & 6)**. Leave hardware loose.

- c. Select (1) Side Spacer Plate. Insert the Side Spacer Plate between the tab on the side of the Bracket and the frame. Orient the Spacer to match the radius cut out of the side of the Bracket, **(Figures 5 & 6)**. Reuse the factory bolts to attach the Bracket and Spacer to the side of the frame. Snug but do not fully tighten hardware at this time.
- d. Repeat the above Steps to install the driver/left Mounting Bracket.

Models with factory receiver hitch

- a. Hold the Passenger/right Mounting Bracket up to the bottom of the frame. Select (1) Side Spacer Plate. Insert the Side Spacer Plate between the tab on the side of the Bracket and the hitch. Orient the Spacer to match the radius cut out of the side of the Bracket. Reuse the (4) factory bolts to attach the Bracket to the bottom and the side of the frame, **(Figures 7, 7A & 7B)**. Snug but do not fully tighten hardware at this time.
NOTE: Only a Side Spacer is required on models with factory receiver hitch to allow Mounting Bracket clearance on the weld.

- b. Repeat the previous Step to attach the driver/left Mounting Bracket.

6. Determine if the Bumper is equipped with back up sensors.

Models without bumper mounted sensors:

- a. Push the (4) sensor plugs into the sockets from the back of the bumper, **(Figure 9)**.

Models with rear facing bumper mounted sensors:

- a. Remove the sensors from the factory bumper.
- b. Remove the rubber plugs from the sockets in the HD bumper assembly, **(Figure 9)**.
- c. Push each sensor in from the back of the bumper. Secure each sensor to the socket with (2) 4mm x 10mm Button Head Screws, **(Figure 9)**. **IMPORTANT:** Sensors fit snug in sockets. The 4mm Screws are used to apply slight pressure to lock the sensors in place. Tighten both screws evenly until they touch the sensor body only. Do not overtighten screws or damage to sensors will result.

7. **NOTE:** HD Bumper has mounting locations for auxiliary back up or flood light installation. If installing lights at this time, check for light clearance through screen **(Figure 10)**.
8. With assistance, position the HD Bumper up to the bumper brackets on the ends of the frame, **(Figure 11)**. Temporarily support the weight of the Bumper Assembly. **WARNING:** To avoid possible injury or damage to the vehicle, do not proceed until the Bumper is safely supported.
9. Line up the (2) mounting holes in the back of the passenger/right side of the bumper with the Mounting Bracket. Attach the Bumper to the Mounting Bracket with (2) 12mm Hex Bolts, (4) 12mm Flat Washers and (2) 12mm Nylon Lock Nuts, **(Figures 11 & 12)**. Leave hardware loose at this time. Repeat to attach the driver/left side of the Bumper to the Bracket.
10. Slowly open the tail gate and check for clearance. Level and adjust the HD Bumper and tighten all hardware.
11. Snap the towing harness plug and license plate lights into the openings in the HD Bumper, **(Figure 13)**. If necessary, use a flat blade screwdriver to carefully pry the lock tab on the clip out to help lock the plug into place.
12. Connect the wiring harness to the license plate light, trailer plug and back up sensors, (if equipped).
13. Insert the included (2) push-in plugs to attach the license plate to the Bumper, **(Figure 13)**.
14. Do periodic inspections to the installation to make sure that all hardware is secure and tight.

To protect your investment, wax this product after installing. Regular waxing is recommended to add a protective layer over the finish. Do not use any type of polish or wax that may contain abrasives that could damage the finish. Mild soap may be used to clean the HD Bumper assembly.

Passenger side installation pictured

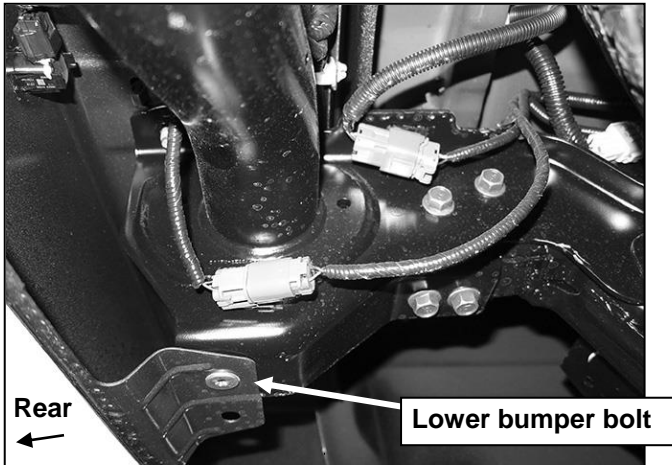

(Fig 1) Unplug wiring harnesses (driver side pictured)

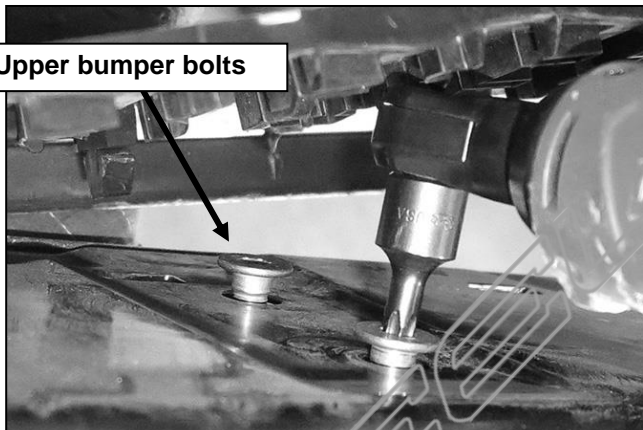
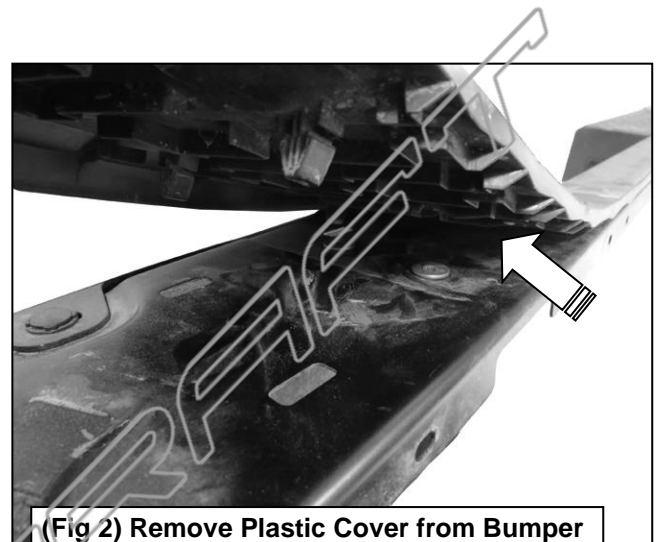

(Fig 3) Remove upper bumper bolts (also see Figure 1 for lower bolt) and remove bumper assembly

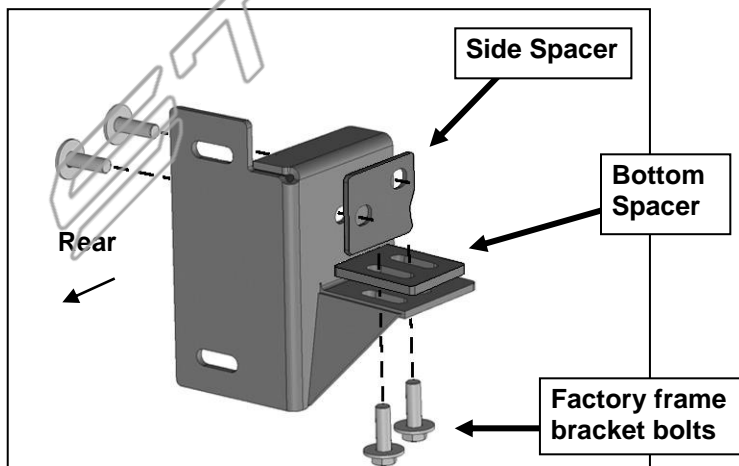

(Fig 5) Passenger/right side Mounting Bracket w-o hitch

WARNING! Do not remove bumper bolts unless the bumper is properly supported on blocks or stands or the bumper may fall.

Passenger side installation pictured

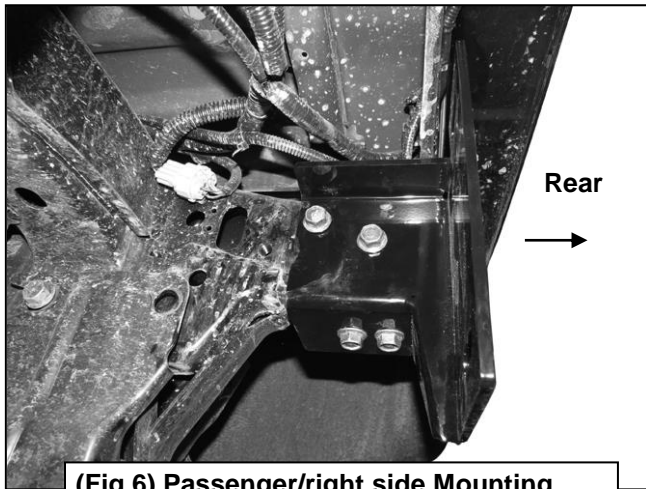

(Fig 6) Passenger/right side Mounting Bracket installed on model without hitch

WARNING! Do not crawl under bumper unless the bumper is properly supported on blocks or stands or the bumper may fall.

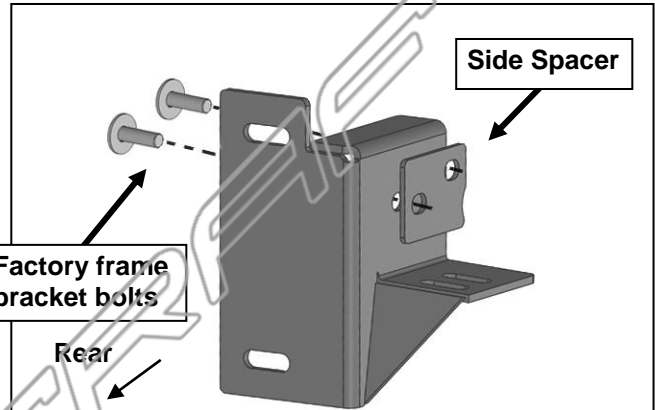

(Fig 7) Passenger/right side Mounting Bracket w-hitch

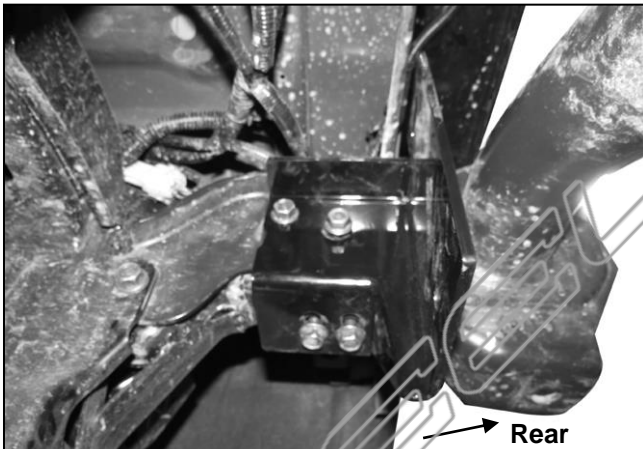

(Fig 8A) Passenger/right Mounting Bracket attached to hitch.

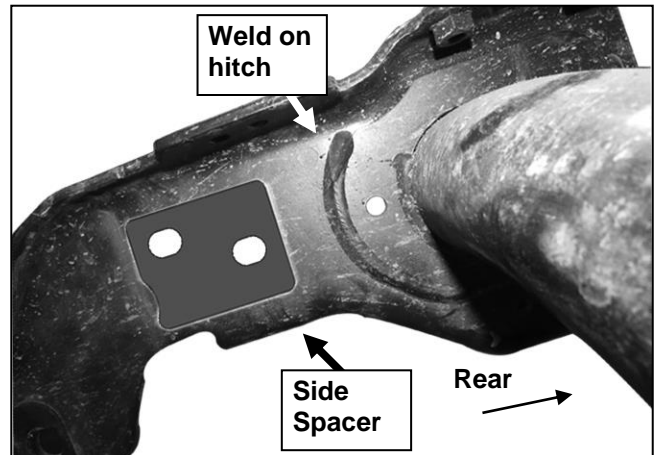

(Fig 8B) Passenger/right side spacer attached to hitch. NOTE: Only a side spacer is required w-hitch so Mounting Bracket can clear the weld

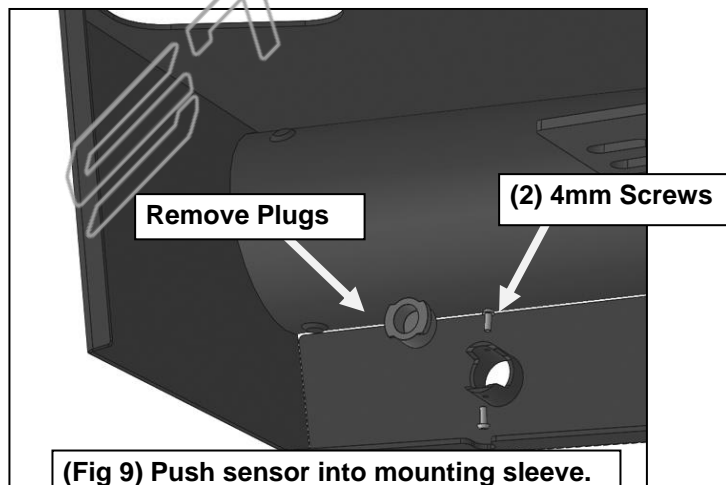

(Fig 9) Push sensor into mounting sleeve. Use 4mm Screws to lock sensor in place.

IMPORTANT: Sensors fit snug in sockets. The 4mm Screws are only used to apply slight pressure to lock the sensors in place. Tighten both screws evenly until they touch the sensor body only. Do not overtighten screws or damage to sensors will result.

Passenger side installation pictured

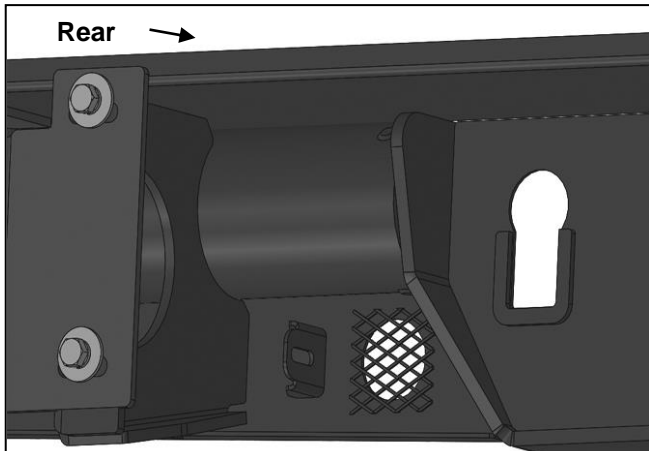

(Fig 10) Mounting Location for Light Installation

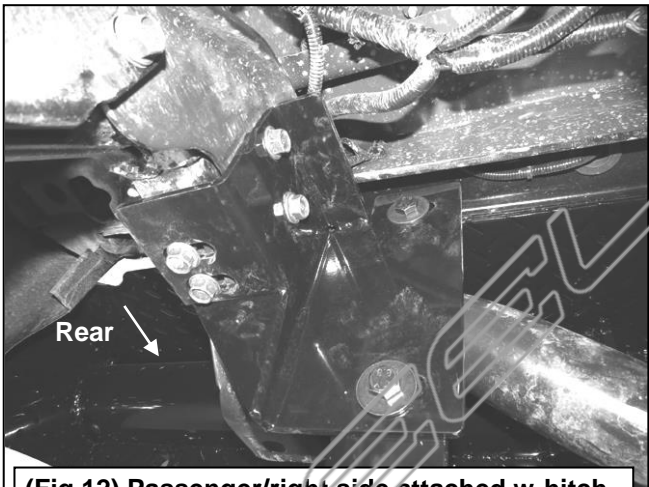

(Fig 12) Passenger/right side attached w-hitch



Complete Installation

WARNING! Do not crawl under bumper unless the bumper is properly supported on blocks or stands or the bumper may fall.

- (2) 12mm Hex Bolts
- (4) 12mm Flat Washers
- (2) 12mm Nylon Lock Nuts

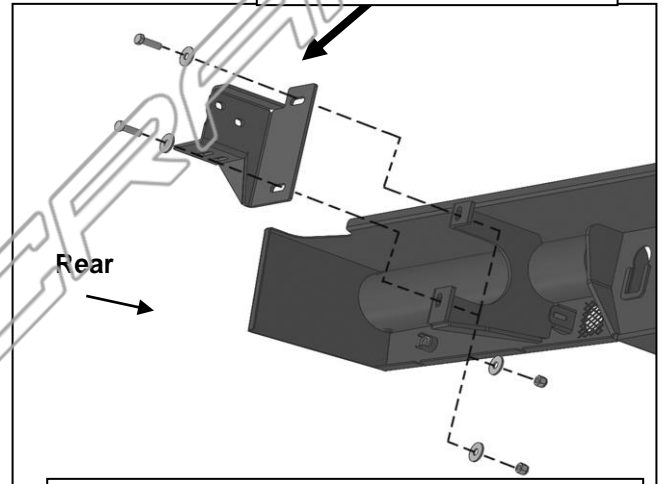

(Fig 11) Attach Mounting Bracket to Bumper

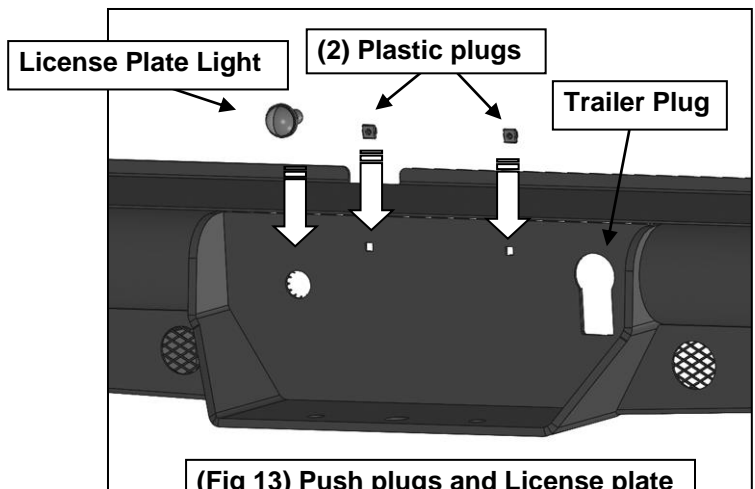

(Fig 13) Push plugs and License plate light into place.