

**HEAVY DUTY FRONT BUMPER
2016-17 NISSAN TITAN XD ONLY**

PARTS LIST:

1	HD Replacement Front Bumper Assembly	24	12mm x 32mm x 3mm Flat Washers
1	Driver/left Frame Mounting Bracket	4	12mm Lock Washers
1	Passenger/right Frame Mounting Bracket	10	12mm Nylon Lock Nuts
1	Driver/left Support Bracket	10	6mm x 25mm Hex Bolts
1	Passenger/right Support Bracket	20	6mm x 18mm x 1.6mm Flat Washers
2	Fog Light Adapter Brackets (L or R)	10	6mm Nylon Lock Nuts
2	Plastic Plugs for license plate mount	8	4mm x 10mm Button Head Bolts
4	Sensor Hole Plugs	1	2.5mm Wrench
4	12-1.25mm x 55mm Special Fine Thread Hex Bolts	1	Sensor Cover Kit
10	12-1.75mm x 60mm Hex Bolts		

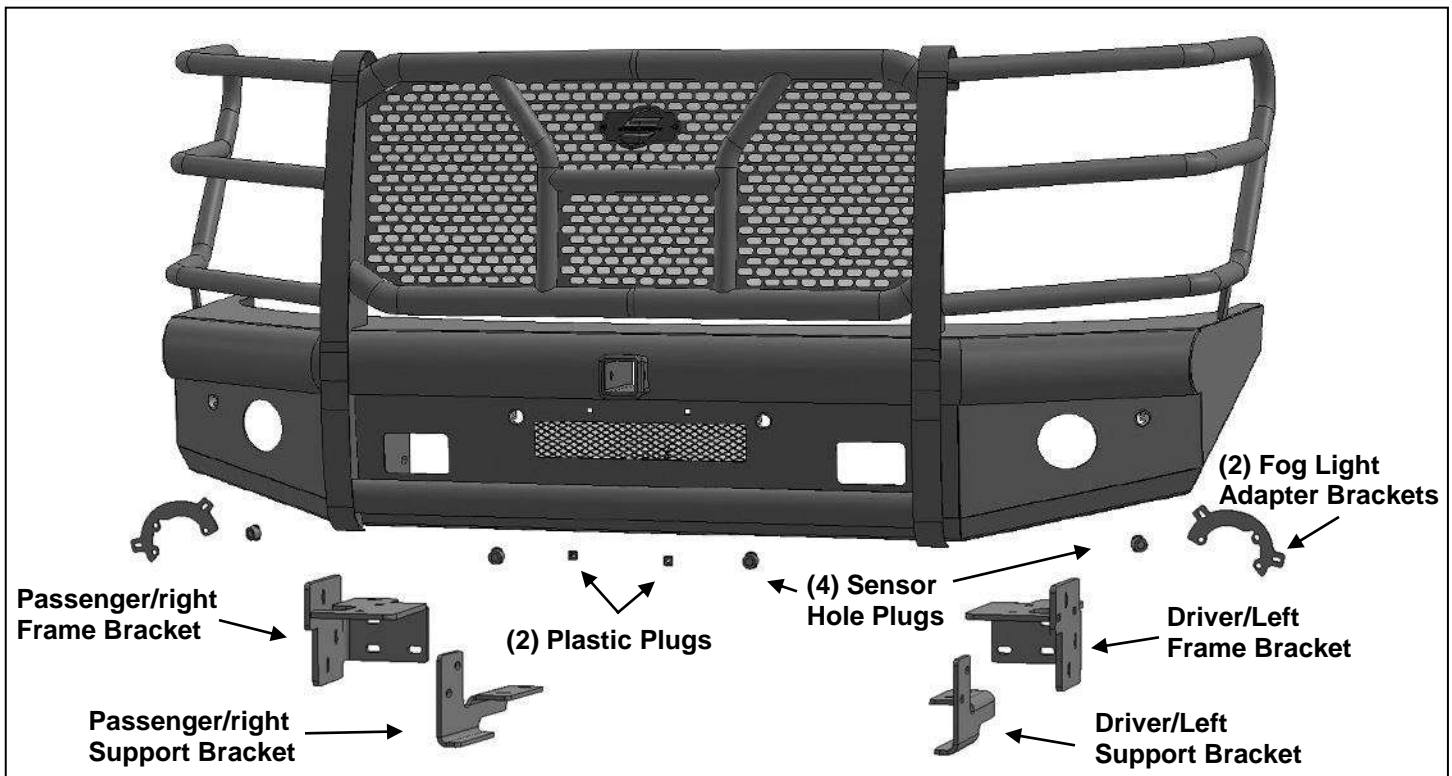

PROCEDURE:

REMOVE CONTENTS FROM BOX. VERIFY ALL PARTS ARE PRESENT. READ INSTRUCTIONS CAREFULLY BEFORE STARTING INSTALLATION. BUMPER IS HEAVY, ASSISTANCE IS HIGHLY RECOMMENDED TO AVOID POSSIBLE INJURY OR DAMAGE TO THE VEHICLE.

1. Remove the license plate. On models with factory fog lights and/or sensors, unplug the wiring harness leading to the bumper. Release the harness from clips attached to the back of the bumper and move harness out of the way.
2. Starting on the driver/left side, remove the plastic panel next to the opening in the bumper, **(Figure 1)**. On models with sensors, remove the panel and unplug the sensor, **(Figure 2)**. On models with tow hooks, remove the tow hooks and the plastic fill panel directly above the tow hook, **(Figure 3)**. On models with skid plate, remove the skid plate. **IMPORTANT:** On models with factory skid plate, skid plate cannot be reinstalled, **(Figure 4)**. Repeat this Step on passenger/right side of vehicle.
3. Next, move to the driver/left inner wheel opening. Remove the hardware attaching the inner bumper reinforcement to the outside of the frame, **(Figure 5)**. Repeat on the passenger/right side of the vehicle.
4. Place blocks or jack stands under the front bumper to support it during mounting bolt removal. Once the bumper has been safely supported, remove the (3) hex bolts attaching each side of the bumper to the bracket on the end of the frame, **(Figure 6)**. **WARNING!** Assistance is required to hold the bumper in

**HEAVY DUTY FRONT BUMPER
2016-17 NISSAN TITAN XD ONLY**

place during hardware removal to prevent the bumper from falling. Slide the bumper assembly off of the end of the frame.

5. Once the bumper assembly has been removed, remove both bumper brackets from the end of the frame, **(Figures 6 & 7)**.
6. Select the driver/left Support Bracket. Reuse the (2) factory tow hook hex bolts or the included (2) 12-1.25mm x 55mm **Special Fine Thread** Hex Bolts, (2) 12mm Lock Washers and (2) 12mm Flat Washers to attach the Support Bracket to the bottom of the frame, **(Figures 8 & 13)**. Leave hardware loose at this time.
7. Next, select the driver/left Frame Mounting Bracket. Reuse the (4) factory hex bolts from the bumper bracket to attach the Frame Bracket to the end of the frame, **(Figures 9 & 13)**. Snug but do not fully tighten all Bracket hardware at this time
8. Repeat **Steps 6 & 7** to install the passenger/right side Frame Mounting Bracket and Support Bracket.
9. Determine if the bumper is equipped with sensors and/or fog lights.

Models without bumper sensors:

- a. Select the included (4) Rubber Plugs.
- b. From behind bumper, push plugs into sensor mounting holes, **(Figure 11)**.

Models with bumper mounted sensors and/or fog lights:

- a. Remove the sensors, fog lights and wiring harness from the bumper, **(Figure 10)**.
 - b. Select (1) sensor. Push the sensor into the mounting socket in the back of the bumper until it is flush (or as close as possible) to the outer edge of the Bumper.
 - c. Secure the sensor to the socket with (2) 4mm x 10mm Button Head Screws, **(Figure 11)**.
IMPORTANT: Sensors fit snug in sockets. The 4mm Screws are used to apply slight pressure to lock the sensors in place. Tighten both screws evenly until they touch the sensor body only. Do not overtighten screws or damage to sensors will result.
 - d. Repeat to install all sensors.
10. With assistance, position the Bumper Assembly up to the Mounting Brackets. Temporarily support the weight of the Bumper. **WARNING:** To avoid possible injury or damage to the vehicle, do not proceed until the Bumper is fully and safely supported.
 11. Attach the driver/left side of the Bumper to the Mounting Bracket and Support Bracket with the included (3) 12-1.75mm x 60mm Coarse Thread STD Hex Bolts, (6) 12mm Flat Washers and (3) 12mm Nylon Lock Nuts, **(Figures 12—14)**. Snug but do not fully tighten hardware at this time. Repeat this Step to attach the passenger/right side of the Bumper to the Brackets.
 12. Level and adjust the bumper and fully tighten all hardware.
 13. On models equipped with tow hooks, attach the driver/left tow hook to the inside of the bumper bracket assembly with the included (2) 12-1.75mm x 60mm Coarse Thread STD Hex Bolts, (4) 12mm Flat Washers and (2) 12mm Nylon Lock Nuts, **(Figure 14)**. Fully tighten hardware at this time. Repeat this Step to install the passenger/right tow hook.
 14. On models equipped with factory fog lights, select (1) Fog Light Adapter Bracket. Attach the Bracket to the driver/left fog light with the included (3) 6mm x 25mm Hex Bolts, (6) 6mm Flat Washers and (3) 6mm Nylon Lock Nuts, **(Figure 15)**. Do not overtighten the hardware. Next, attach the light with Bracket to the mounting tabs on the back of the bumper with the included (2) 6mm x 25mm Hex Bolts, (4) 6mm Flat Washers and (2) 6mm Nylon Lock Nuts, **(Figures 15 & 16)**. Repeat this Step to attach the passenger/right fog light.
 15. Reinstall the wiring harness to the sensors and/or fog lights, **(Figure 16)**.
 16. If front license plate is required, insert (2) Plastic Plugs into the square holes in the Bumper. Reuse the factory screws to attach the license plate to the plastic plugs, **(Figure 17)**.
 17. On models with grille mounted factory camera, remove screen covering opening in Grille Guard, **(Figure 18)**.
 18. Do periodic inspections to the installation to make sure that all hardware is secure and tight.

To protect your investment, wax this product after installing. Regular waxing is recommended to add a protective layer over the finish. Do not use any type of polish or wax that may contain abrasives that could damage the finish. Mild soap may be used to clean the Bumper assembly.

HEAVY DUTY FRONT BUMPER
2016-17 NISSAN TITAN XD ONLY

Driver Side Installation Pictured



(Fig 1) Remove fill panel to access bumper bolts

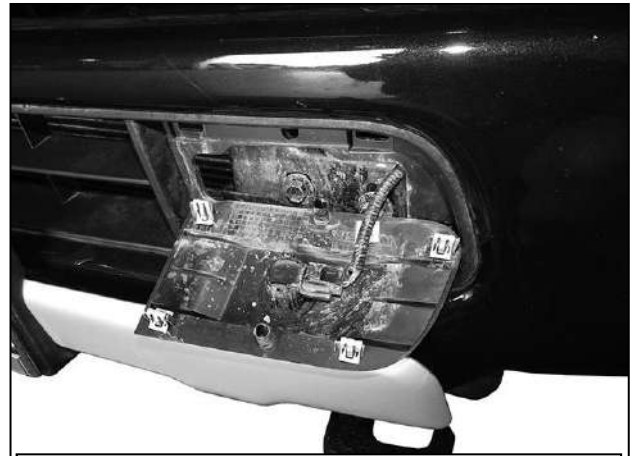

(Fig 2) Models with sensors, unplug sensors



(Fig 3) Remove plastic panel above tow hook



(Fig 4) Remove skid plate if equipped

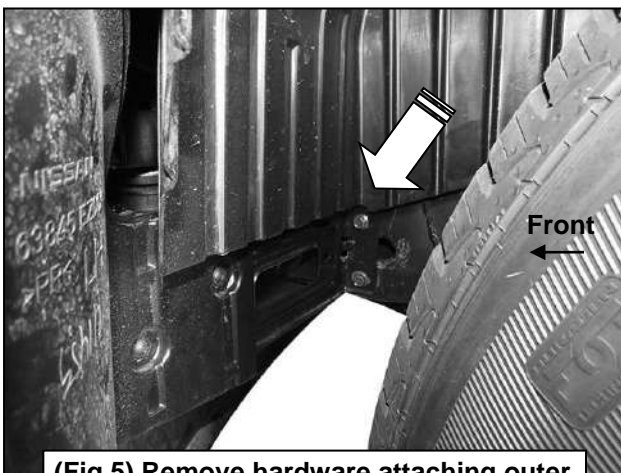

(Fig 5) Remove hardware attaching outer bumper support to side of frame (arrow)

WARNING! Do not remove bumper bolts unless the bumper is properly supported on blocks or stands or the bumper may fall.

**HEAVY DUTY FRONT BUMPER
2016-17 NISSAN TITAN XD ONLY**

Driver Side Installation Pictured

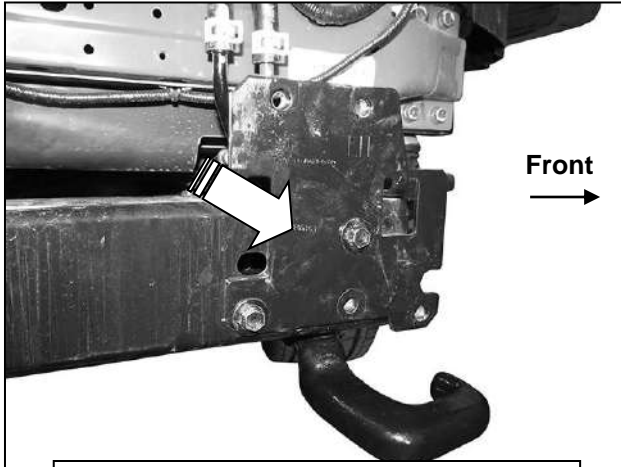

(Fig 6) Remove bumper bracket (arrow) and tow hook if equipped

WARNING! Do not remove bumper bolts unless the bumper is properly supported on blocks or stands or the bumper may fall.

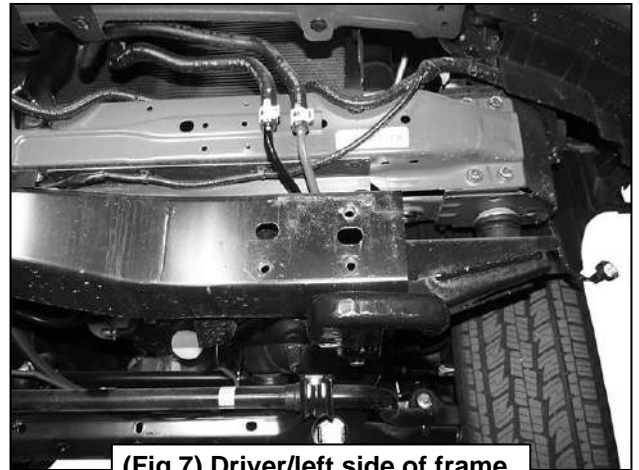

(Fig 7) Driver/left side of frame

Models without tow hooks use the included:
(2) 12-1.25mm x 55mm **Special Fine Thread Hex Bolts**
(2) 12mm Lock Washers
(2)12mm Flat Washers

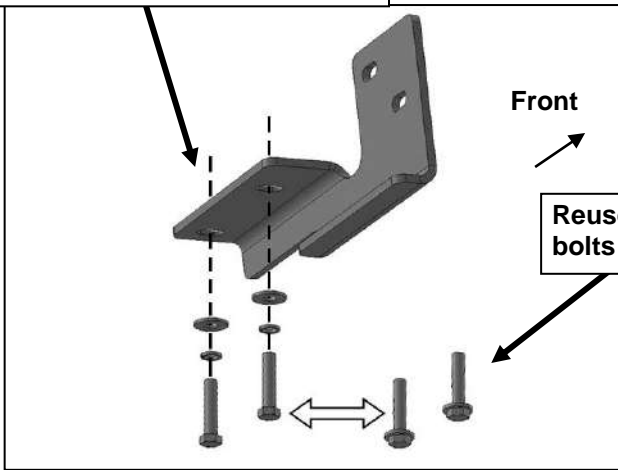

Reuse tow hook bolts if equipped

(Fig 8) Attach driver/left Support Bracket to threaded holes (tow hook) in bottom of frame

Reuse factory bumper bracket hardware to attach driver/left Frame Bracket to threaded holes in end of frame for bumper bracket

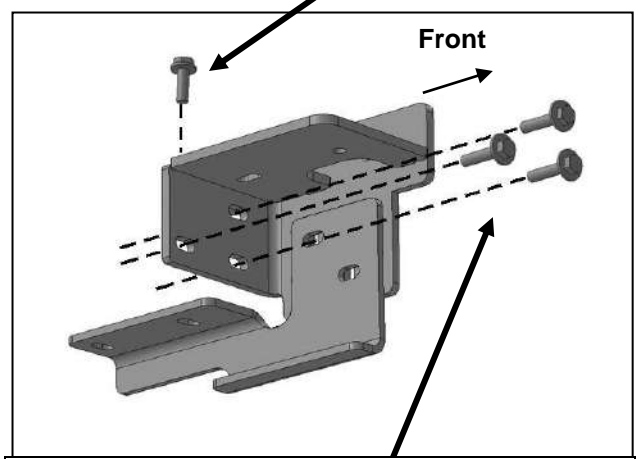

(Fig 9) Reuse factory bumper bracket hardware to attach driver/left Frame Bracket to threaded holes in end of frame for bumper bracket

**HEAVY DUTY FRONT BUMPER
2016-17 NISSAN TITAN XD ONLY**

Driver Side Installation Pictured

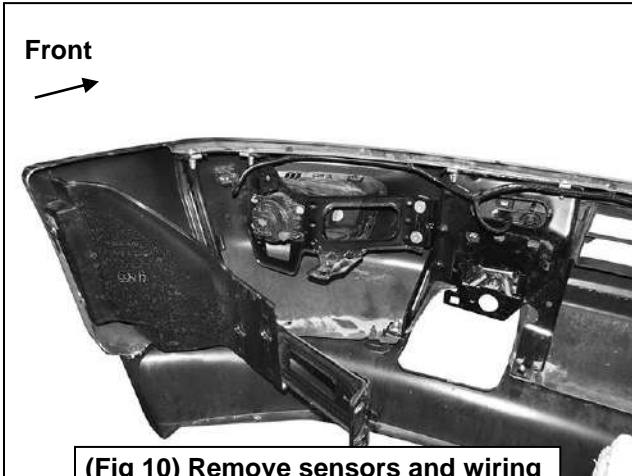

(Fig 10) Remove sensors and wiring harness (if equipped) from bumper

IMPORTANT: Sensors fit snug in sockets. The 4mm Screws are only used to apply slight pressure to lock the sensors in place. Tighten both screws evenly until they touch the sensor body only. Do not overtighten screws or damage to sensors will result.

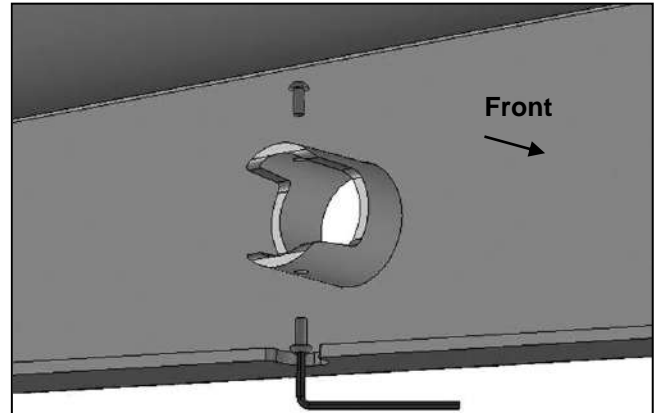

(Fig 11) Push sensor into mounting sleeve. Use 4mm Screws to lock sensor in place.

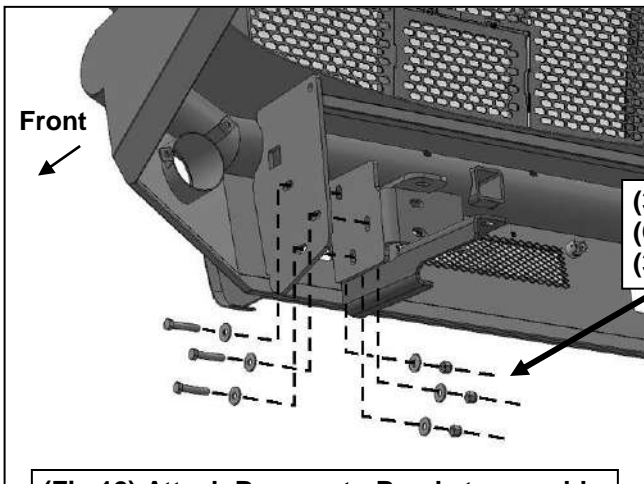

- (3) 12-1.75mm x 60mm Hex Bolts
- (6) 12mm Flat Washers
- (3) 12mm Nylon Lock Nuts

(Fig 12) Attach Bumper to Bracket assembly

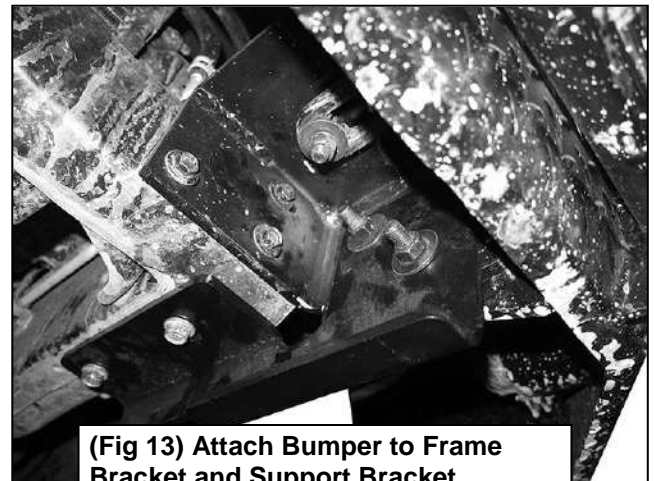

(Fig 13) Attach Bumper to Frame Bracket and Support Bracket, (driver/left side pictured from below)

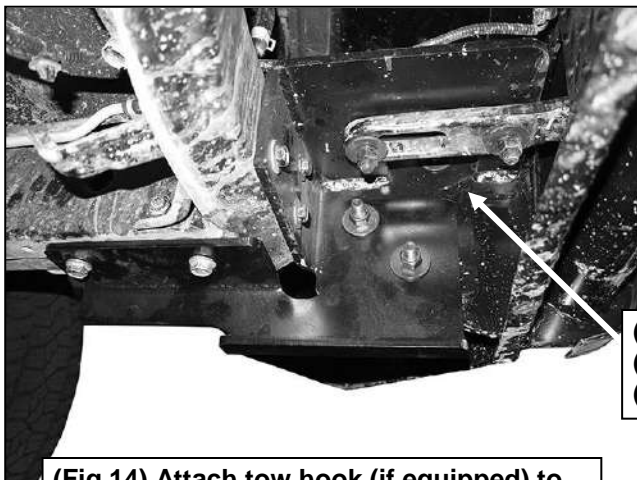

(Fig 14) Attach tow hook (if equipped) to inside of Frame Bracket, (driver/left side pictured from below)

- (2) 12-1.75mm x 60mm Hex Bolts
- (4) 12mm Flat Washers
- (2) 12mm Nylon Lock Nuts

WARNING! Do not crawl under bumper unless the bumper is properly supported on blocks or stands or the bumper may fall.

**HEAVY DUTY FRONT BUMPER
2016-17 NISSAN TITAN XD ONLY**

Driver Side Installation Pictured

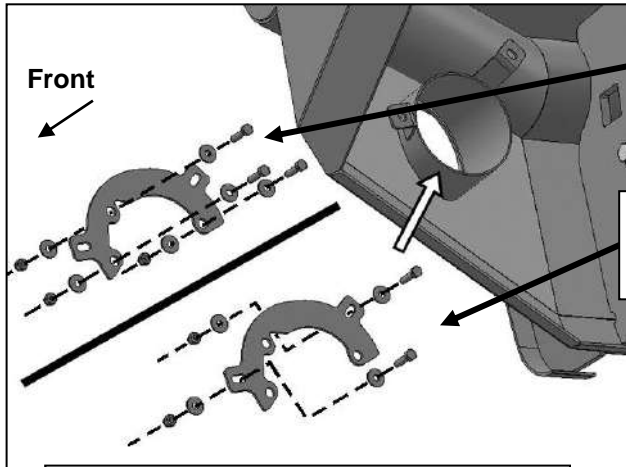

Attach the Adapter Bracket to the fog light first if equipped
(3) 6mm Hex Bolts
(6) 6mm Flat Washers
(3) 6mm Nylon Lock Nuts

(2) 6mm Hex Bolts
(4) 6mm Flat Washers
(2) 6mm Nylon Lock Nuts

(Fig 15) Attach the light with Bracket to mounting tabs on the Bumper (arrow)

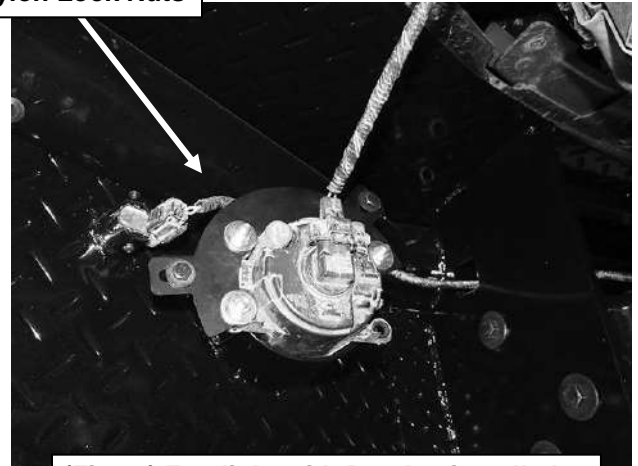

(Fig 16) Fog light with Bracket installed

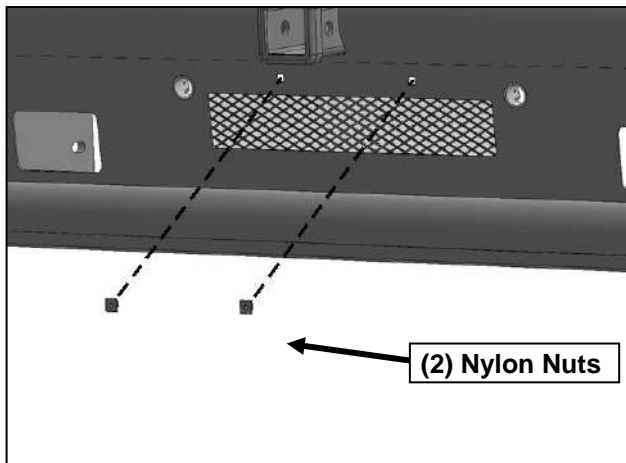

(2) Nylon Nuts

(Fig 17) Attach License Plate Bracket to Bumper

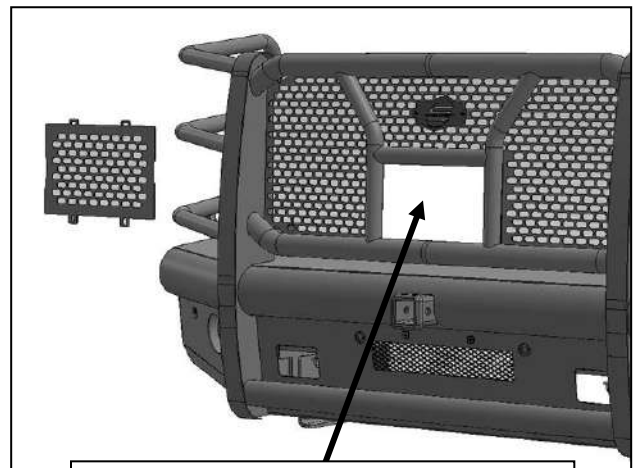

(Fig 18) Remove screen from grille for models with grille mounted camera



Complete Installation