

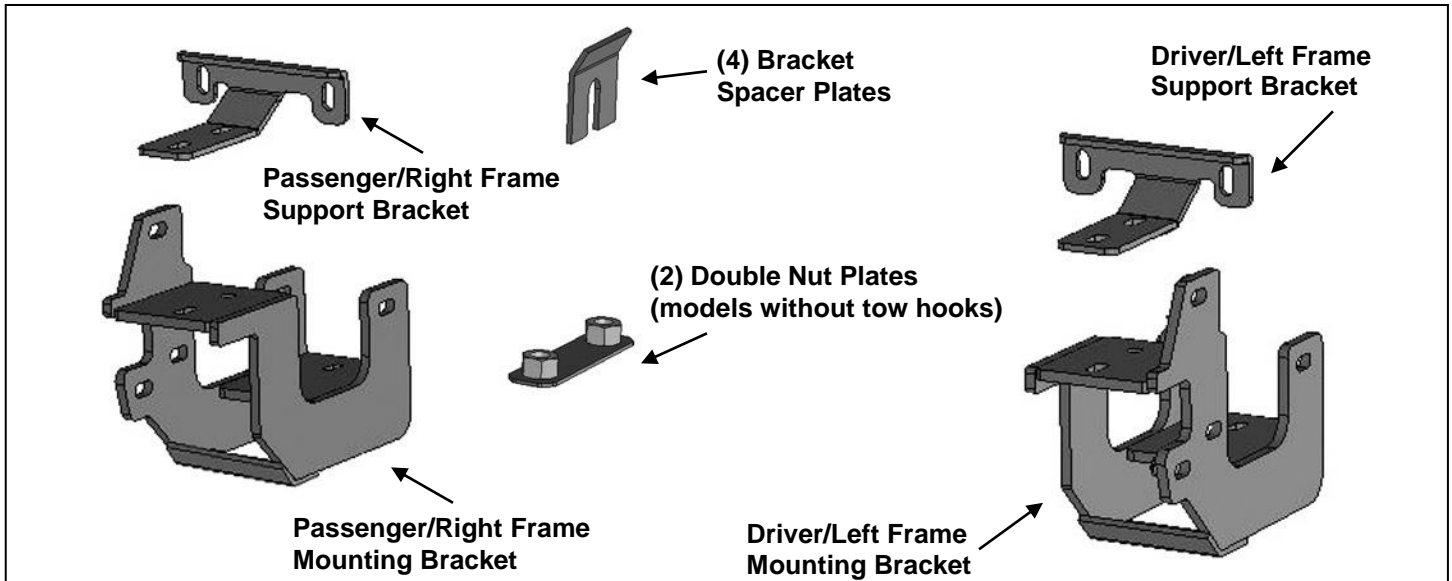

**INSTALLATION INSTRUCTIONS**  
**HEAVY DUTY FRONT BUMPER**  
**2015 FORD F150**

**PARTS LIST:**

1	Heavy Duty Front Bumper Assembly	14	12-1.75mm x 45mm Hex Bolts
1	Driver/Left Frame Mounting Bracket	28	12mm x 37mm x 3mm Flat Washers
1	Passenger/Right Frame Mounting Bracket	12	12-1.75mm Nylon Lock Nuts
1	Driver/Left Frame Support Bracket	4	12mm Lock Washers
1	Passenger/Right Frame Support Bracket	8	6mm x 25mm Hex Bolts
4	Bracket Spacer Plates	16	6mm x 18mm x 1.6 Flat Washers
2	12mm Double Nut Plates	8	6mm Nylon Lock Nuts
2	12-1.75mm x 170mm Hex Bolts	2	Plastic Plugs for license plate mount



**PROCEDURE:**

**REMOVE CONTENTS FROM BOX. VERIFY ALL PARTS ARE PRESENT. READ INSTRUCTIONS CAREFULLY BEFORE STARTING INSTALLATION. BUMPER IS HEAVY, ASSISTANCE IS HIGHLY RECOMMENDED TO AVOID POSSIBLE INJURY OR DAMAGE TO THE VEHICLE. BUMPER INSTALLATION WILL INTERFERE WITH GRILLE MOUNTED CAMERA.**

1. Remove the license plate and bracket. On models with factory fog lights, unplug both lights and remove the complete light assemblies from back of bumper, **(Figure 1)**. Release the wiring harness from the clips attached to the back of the bumper. Move harness away from bumper.
2. Next, remove the plastic bumper pad assembly, **(Figure 2)**. **NOTE:** Release metal clips from back of bumper to remove bumper pad assembly. It may be easier to access bumper hardware with plastic air dam removed from bottom of bumper.
3. Place blocks or jack stands under the front bumper to support it during mounting bolt removal. Once the bumper has been safely supported, remove the large hex nut from the back of each bumper bracket, **(Figure 3)**. Next, from the front of the bumper, remove the (2) factory hex nuts attaching the bumper to each bumper bracket, **(Figure 4)**. **WARNING!** Assistance is required to hold the bumper in place during bolt removal to prevent the bumper from falling. Carefully slide the bumper off over the tow hooks.
4. Remove the driver side tow hook, (if equipped), from the bottom of the frame. On models without tow hook, insert (1) Double Nut Plate into the open end of the frame, **(Figure 5)**. Repeat to remove the passenger side tow hook.
5. Next, select the driver side Frame Mounting Bracket. Attach the Bracket to the bottom of the frame and Double Nut Plate with (2) 12mm x 45mm Hex bolts, (2) 12mm Lock Washers and (2) 12mm Flat Washers, **(Figure 6)**. Leave hardware loose at this time.
6. Remove the factory double bolt plate from the top of the bumper flange on the frame, **(Figure 7)**. Select the driver side Frame Support Bracket. Place the Support Bracket on top of the Frame Mounting Bracket. Insert the factory double bolt plate through the Support Bracket and bumper flange, **(Figure 8)**.

Reuse the factory hex nuts to secure the Support Bracket to the factory double bolt plate. Do not fully tighten at this time.

7. Insert (1) 12mm x 170mm Long Hex Bolt with (1) 12mm Flat Washer through the outside of the mounting tab on the Frame Bracket, through the frame and inside tab. Secure with (1) 12mm Flat Washer and (1) 12mm Nylon Lock Nut. Insert (1) Spacer Plate down between each mounting tab and the side of the frame, **(Figures 9 & 10)**. Do not fully tighten hardware.
8. Next, on models with tow hooks, attach the tow hook to the inside of the frame Bracket and Support Bracket with the included 12mm Double Nut Plate, (2) 12mm x 45mm Hex Bolts, (2) 12mm Lock Washers and (2) 12mm Flat Washers, **(Figure 9)**. On models without tow hooks, attach the Support Bracket directly to the top of the Frame Bracket with (2) 12mm x 45mm Hex Bolts, (4) 12mm Flat Washers and (2) 12mm Nylon Lock Nuts, **(Figure 9)**. Do not tighten at this time.
9. Repeat **Steps 4—8** to install the passenger side Frame Bracket assembly.
10. With assistance, position the Bumper Assembly up to and over the Frame Brackets. Temporarily support the weight of the Bumper. **WARNING:** To avoid possible injury or damage to the vehicle, do not proceed until the bumper is fully and safely supported.
11. Line up the (3) holes in the driver side Frame Bracket with the (3) holes in the inner mounting plate on the back of the Bumper. Attach the Bumper to the Bracket with the included (3) 12mm x 45mm Hex Bolts, (6) 12mm Flat Washers and (3) 12mm Nylon Lock Nuts, **(Figures 11 & 12)**. Snug but do not tighten hardware at this time. Repeat this Step to attach the passenger side of the Bumper to the Frame Bracket.
12. Level and adjust the bumper and fully tighten all hardware to 65-70ft-lbs. **NOTE:** If additional in-out adjustment is required, loosen Frame Bracket Hardware, slide the Bracket in or out as necessary and fully tighten all hardware.
13. **Models with fog lights:**
  - a. Line up the driver side fog light assembly with the (4) mounting tabs welded onto the back of the bumper. Attach the fog light assembly to the tabs with the included (4) 6mm x 25mm Hex Bolts, (8) 6mm Flat Washers and (4) 6mm Nylon Lock Nuts, **(Figure 13)**. Mounting tabs may move during shipping. Use hand tools to carefully adjust mounting tabs to line up flat with plastic fog light housing. **IMPORTANT:** Do not overtighten 6mm hardware attaching fog light to Bumper or plastic housing may be damaged.
  - b. Repeat to install the passenger side fog light assembly.
  - c. Reattach the factory wiring harness to both lights.
14. Use the included (2) push-in plastic nuts to attach the front license plate, (if required), to the (2) holes in the front bumper, **(Figure 14)**.
15. Do periodic inspections to the installation to make sure that all hardware is secure and tight.

**To protect your investment**, wax this product after installing. Regular waxing is recommended to add a protective layer over the finish. Do not use any type of polish or wax that may contain abrasives that could damage the finish. Mild soap may be used to clean the Heavy Duty Front Bumper assembly.

**Driver Side Installation Pictured**

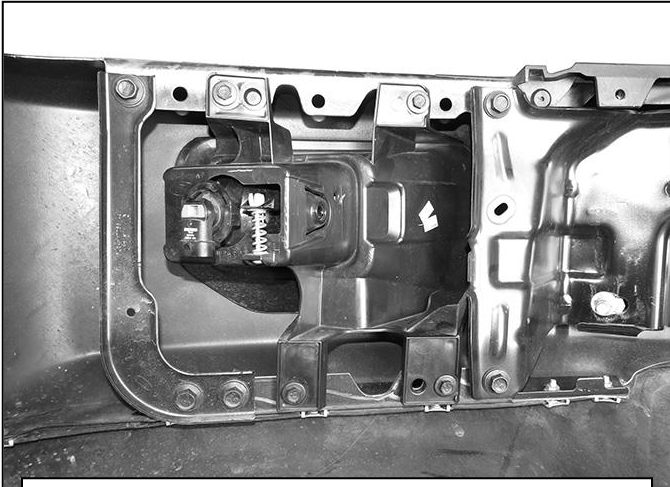

**(Fig 1) Remove fog light assembly from bumper**



Front  
↓

**(Fig 2) Remove license plate. From behind bumper, release metal clips attaching plastic bumper pad to the bumper**



Front  
↙

**(Fig 3) Remove factory hex nut (arrow) from back of bumper bracket**

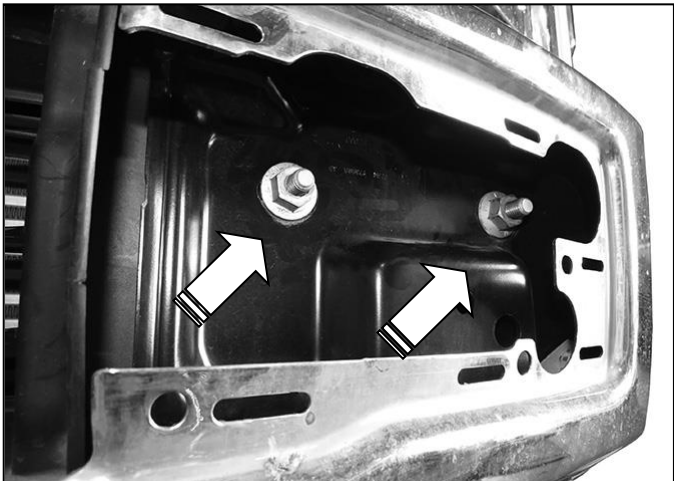

**(Fig 4) Remove (2) factory hex nuts from each side**

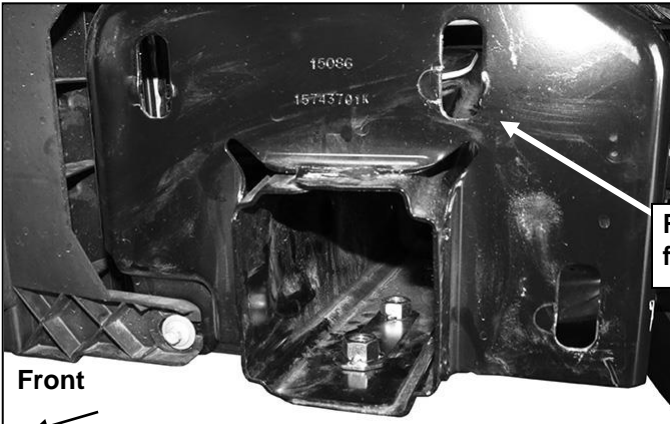

Front  
↙

**Remove factory double bolt plate from back of bumper bracket**

**(Fig 5) Reuse factory double nut plate (models with tow hooks) or insert included Double Nut Plate into end of frame**

**WARNING!** Do not remove bumper bolts unless the bumper is properly supported on blocks or stands or the bumper may fall.

Driver Side Installation Pictured

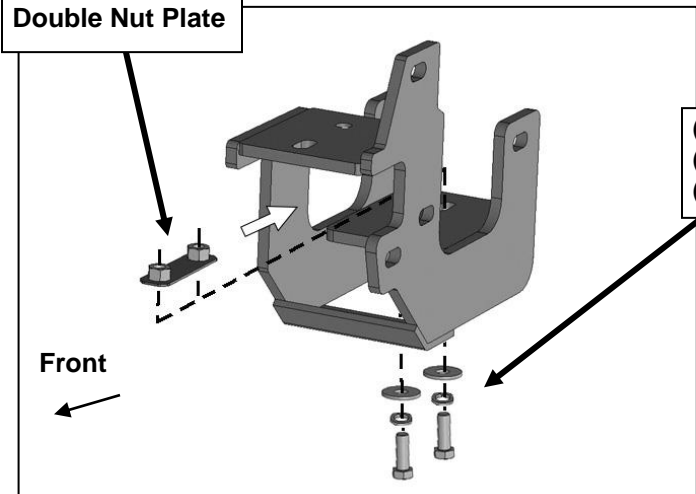

- (2) 12mm x 45mm Hex Bolts
- (2) 12mm Lock Washers
- (2) 12mm Flat Washers

Driver/left Frame Support Bracket

(Fig 6) Slide Bracket assembly over end of frame. Attach assembly to Double Nut Plate in frame (Fig 5)

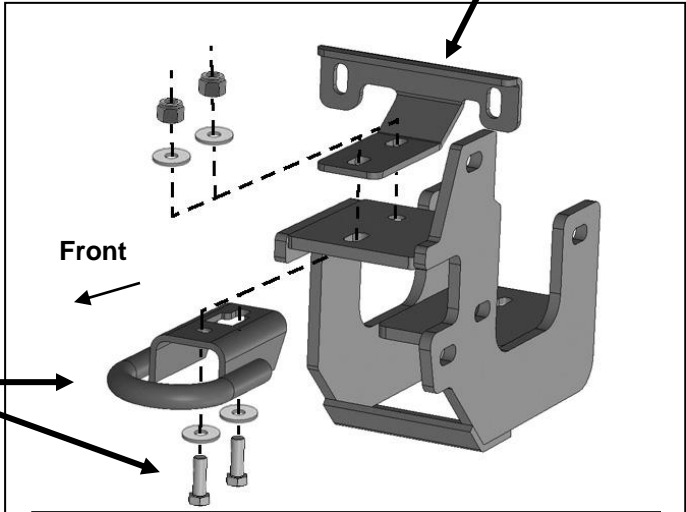

- Tow Hook (if equipped)
- (2) 12mm x 45mm Hex Bolts
- (4) 12mm Flat Washers
- (2) 12mm Nylon Lock Nuts

(Fig 7) Attach Support Bracket to top of Bracket Assembly and factory tow hook (if equipped)

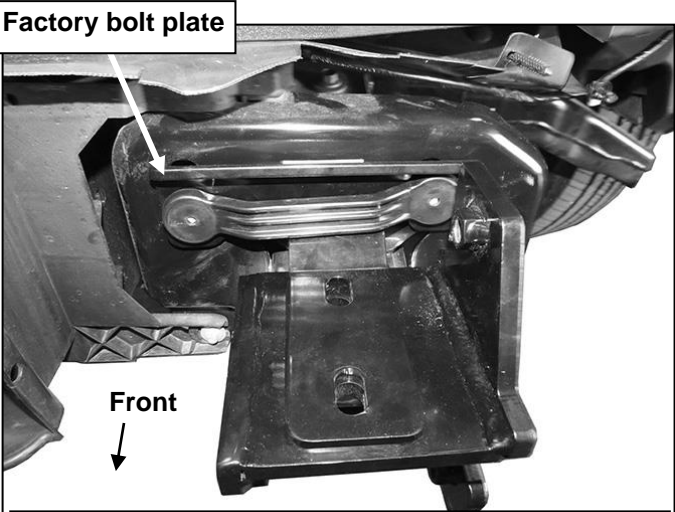

(Fig 8) Reuse factory double bolt plate and hex nuts to attach Support Bracket to bumper bracket

- (2) Spacers
- 12mm x 170mm Long Hex Bolt
- (2) 12mm Flat Washers
- 12mm Nylon Lock Nut

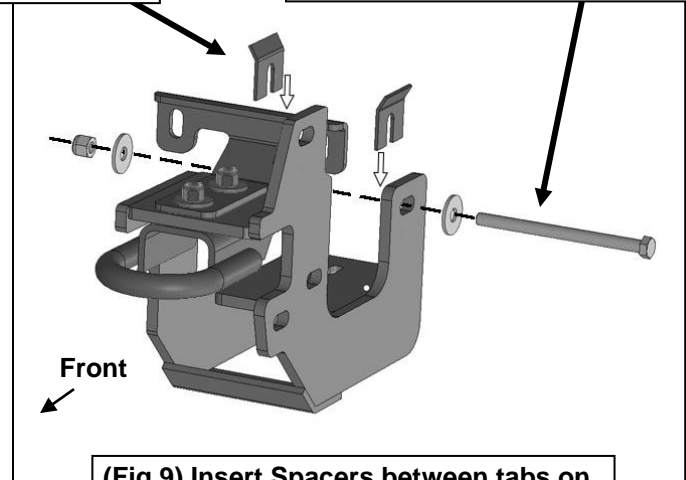

(Fig 9) Insert Spacers between tabs on Bracket assembly and sides of frame

**WARNING!** Do not crawl under bumper unless the bumper is properly supported on blocks or stands or the bumper may fall.

**Driver Side Installation Pictured**

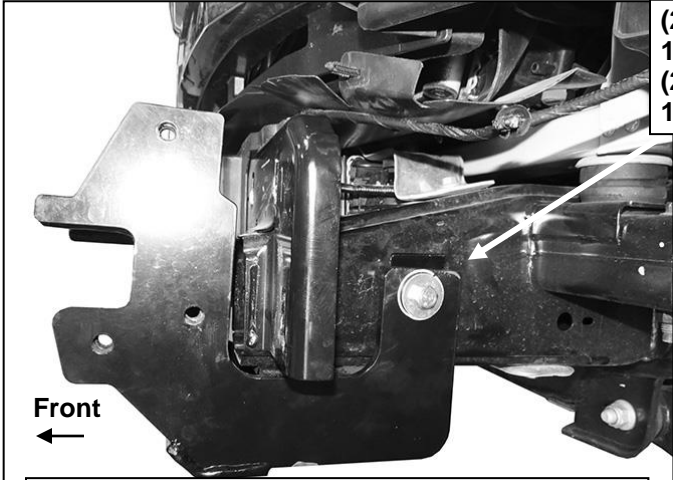

- (2) Frame Spacers
- 12mm x 170mm Long Hex Bolt
- (2) 12mm Flat Washers
- 12mm Nylon Lock Nut

(Fig 10) Driver side Bracket Assembly pictured

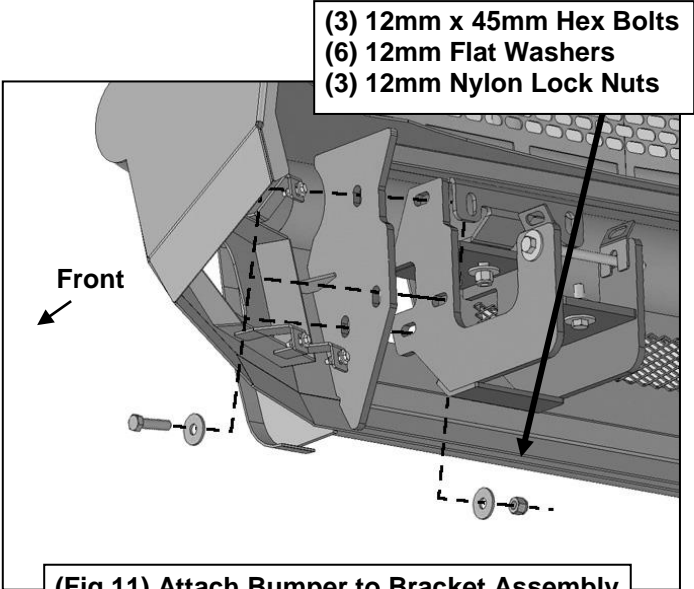

- (3) 12mm x 45mm Hex Bolts
- (6) 12mm Flat Washers
- (3) 12mm Nylon Lock Nuts

(Fig 11) Attach Bumper to Bracket Assembly

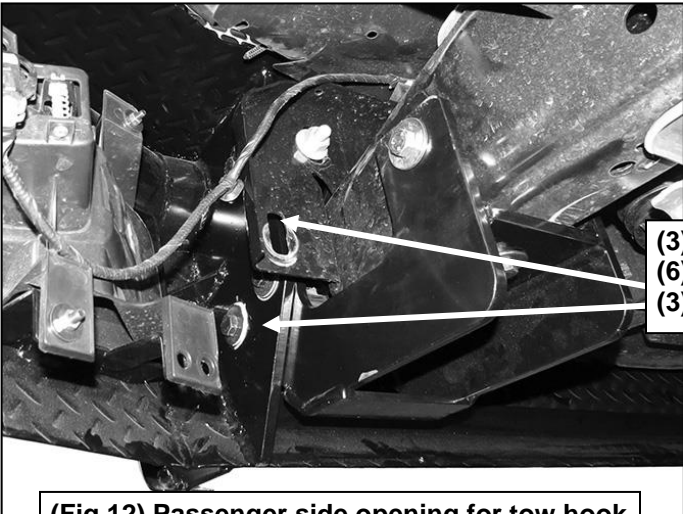

- (3) 12mm x 45mm Hex Bolts
- (6) 12mm Flat Washers
- (3) 12mm Nylon Lock Nuts

(Fig 12) Passenger side opening for tow hook

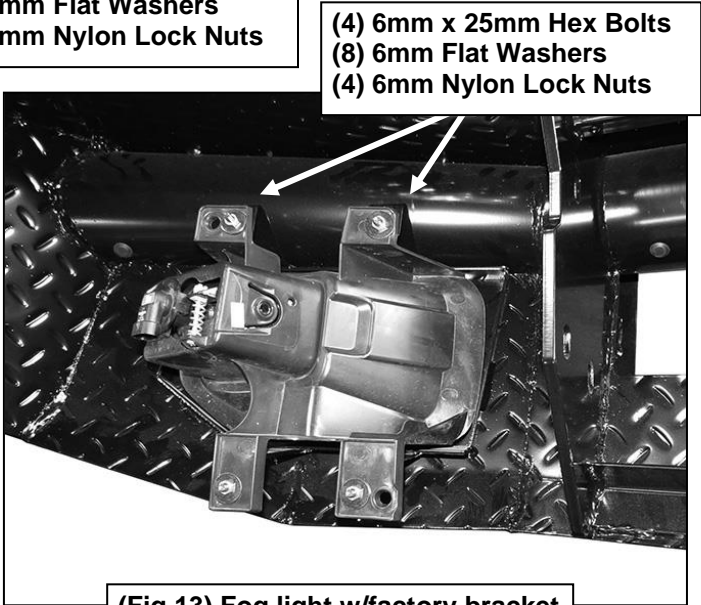

- (4) 6mm x 25mm Hex Bolts
- (8) 6mm Flat Washers
- (4) 6mm Nylon Lock Nuts

(Fig 13) Fog light w/factory bracket

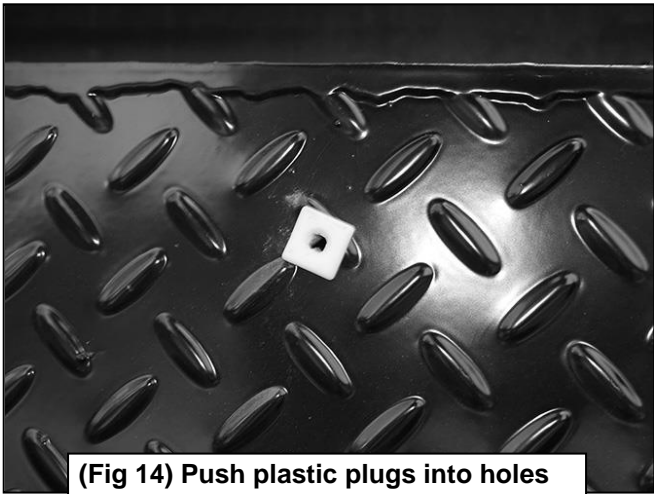

(Fig 14) Push plastic plugs into holes in Bumper for license plate if required