

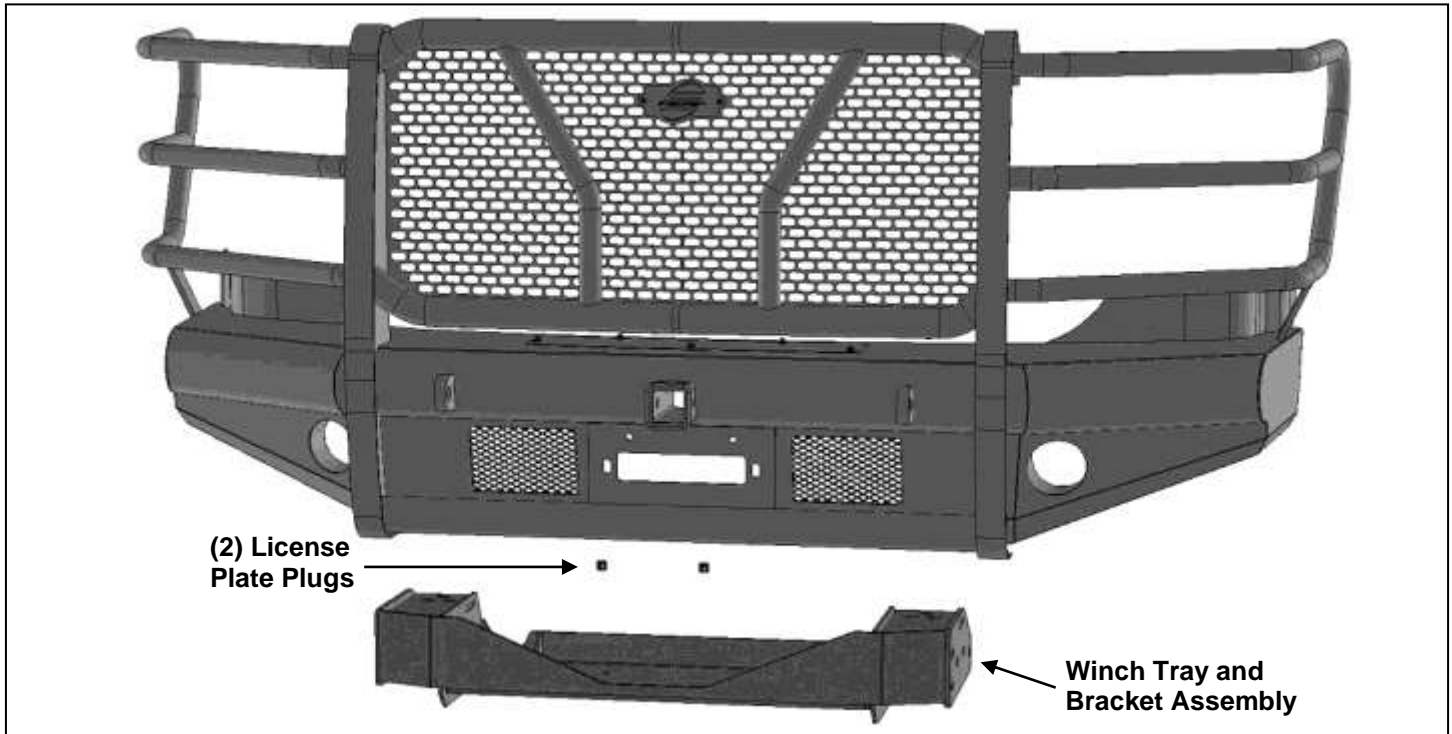

HD REPLACEMENT WINCH FRONT BUMPER 2011-16 FORD SUPERDUTY F250-350

PARTS LIST:

1	HD Replacement Front Bumper Assembly	18	12-1.75mm Hex Nuts
1	Winch Tray Bracket Assembly	5	6mm Combo Button Head Bolts (cover)
1	Bumper Cover Plate	4	5mm x 20mm Button Head Bolts
2	Plastic Plugs for license plate mount	8	5mm x 10mm x 1mm Flat Washers
18	12-1.75mm x 50mm Hex Bolts	4	5mm Nylon Lock Nuts
36	12mm x 32mm x 3mm Flat Washers	1	4mm Wrench
18	12mm Lock Washers	1	3mm Wrench



PROCEDURE:

REMOVE CONTENTS FROM BOX. VERIFY ALL PARTS ARE PRESENT. READ INSTRUCTIONS CAREFULLY BEFORE STARTING INSTALLATION. BUMPER IS HEAVY, ASSISTANCE IS HIGHLY RECOMMENDED TO AVOID POSSIBLE INJURY OR DAMAGE TO THE VEHICLE.

1. Remove the license plate and bracket. On models with factory fog lights, unplug wiring harness leading to the bumper, **(Figures 1 & 2)**. Move harness away from bumper.
2. Release the rubber air deflector from the back of the bumper. Next, remove the driver and passenger side outer bumper supports attached to the outside of the frame, **(Figure 2)**.
3. Place blocks or jack stands under the front bumper to support it during mounting bolt removal. Once the bumper has been safely supported, remove the (4) factory bumper bolts, **(Figure 3)**. **WARNING!** Assistance is required to hold the bumper in place during bolt removal to prevent the bumper from falling. Carefully slide the bumper off and over the tow hooks.
4. Remove the driver/left side tow hook from the top of the frame, **(Figure 4)**. Next, remove the (4) factory hex nuts, lower frame extension, (if equipped), and double bolt plates from the end of the frame, **(Figures 1, 4 & 5)**. Repeat this **Step** to remove the passenger/right side tow hook and lower frame extension.
5. Next, select the Winch Tray/Bracket Assembly. Slide the assembly over the end of the frame. Line up the slots in the top of the Bracket Assembly with the holes in the top of the frame for the tow hooks. Attach the Bracket Assembly to the driver/left side of the frame with the included (3) 12mm Hex Bolts, (6) 12mm Flat Washers, (3) 12mm Lock Washers and (3) 12mm Hex Nuts, **(Figures 6 & 7)**. Leave hardware loose.

**HD REPLACEMENT WINCH FRONT BUMPER
2011-16 FORD SUPERDUTY F250-350**

6. Line up the (2) slots in the outside of the Bracket Assembly with the holes in the side of the frame, **(Figure 8)**. Attach the Bracket Assembly to the outside of the frame with (2) 12mm Hex Bolts, (4) 12mm Flat Washers, (2) 12mm Lock Washers and (2) 12mm Hex Nuts, **(Figures 8 & 9)**. Leave hardware loose.
7. Attach the rear corner of the driver/left side of the Winch Tray to the hole in the inside of the frame with (1) 12mm Hex Bolt, (2) 12mm Flat Washers, (1) 12mm Lock Washer and (1) 12mm Hex Nut, **(Figures 10 & 11)**. Leave hardware loose.
8. Repeat **Steps 5—7** to attach the passenger/right side of the Winch Tray/Bracket Assembly to the frame.
9. If installing winch, attach winch to Winch Tray at this time. Winch must be installed before Bumper is placed in position against Brackets. Also attach winch cable guide to Bumper. Follow manufacturer's instructions to properly wire the winch to the electrical system.
10. With assistance, carefully position the Bumper Assembly up to the ends of the Winch Tray. Temporarily support the weight of the Bumper. **WARNING:** To avoid possible injury or damage to the vehicle, do not proceed until the Bumper is fully and safely supported. Models with winch, check for clearance between Bumper and winch before fully installing Bumper.
11. Line up the (3) mounting holes in the driver/left side of the Bumper with the (3) holes in the Winch Tray/Bracket Assembly. Attach the Bumper to the Bracket Assembly with the included (3) 12mm Hex Bolts, (6) 12mm Flat Washers, (3) 12mm Lock Washers and (3) 12mm Hex Nuts, **(Figures 12 & 13)**. Do not fully tighten hardware at this time. Repeat to attach the passenger/right side of the Bumper to the Bracket Assembly.
12. Level and adjust the bumper and fully tighten all 12mm hardware to 65-70ft-lbs.
13. **Models with factory fog lights:**
 - a. Use a flat blade screwdriver or pliers to pop off the round outer metal clip over each of the hex nuts attaching the plastic light bracket to the back of the factory bumper, **(Figure 14)**. Remove the hex nuts and the light assembly, **(Figure 15)**.
 - b. Next, use a flat blade screwdriver to pry up the center pin on the (2) fasteners attaching the top of the light to the bracket, **(Figure 15)**.
 - c. Remove the adjustment screw, spring and plastic nut from the bottom of the light.
 - d. Slide the light into place between the mounting tabs on the back of the Bumper. Use the included (2) 5mm Button Head Bolts, (4) 5mm Flat Washers and (2) 5mm Nylon Lock Nuts to attach the top of the light to the mounting tabs, **(Figure 16)**. Attach the plastic nut to the lower bent tab on the Bumper. Insert the screw through the tab on the light, the spring (between light and tab on bumper), and into the plastic nut. Adjust the light as needed.
 - e. Repeat to install the remaining fog light.
 - f. Reattach the factory wiring harness to both lights.
14. Use the included (2) push-in plastic plugs to attach the front license plate, (if required), to the (2) holes in the front bumper, **(Figure 17)**.
15. Remove winch access cover if desired, **(Figure 17)**.
16. Do periodic inspections to the installation to make sure that all hardware is secure and tight.

To protect your investment, Do not use any type of polish or wax that may contain abrasives that could damage the finish. Mild soap may be used to clean the Front Bumper assembly.

HD REPLACEMENT WINCH FRONT BUMPER
2011-16 FORD SUPERDUTY F250-350

Driver Side Installation Pictured

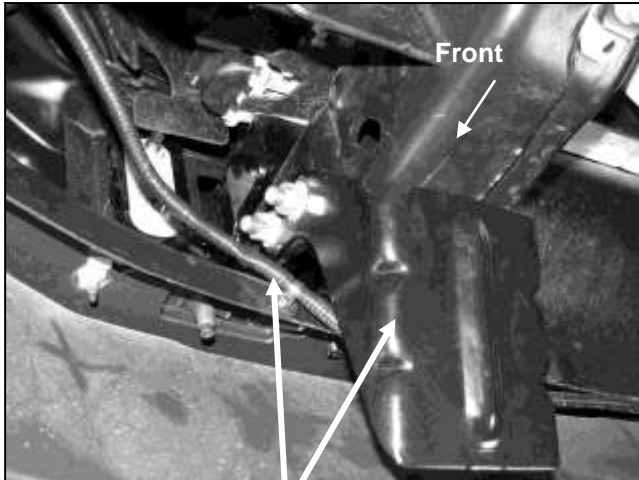

(Fig 1) Driver/left lower frame extension and fog light wire harness pictured from behind bumper

Remove hardware attaching bumper support brackets to frame

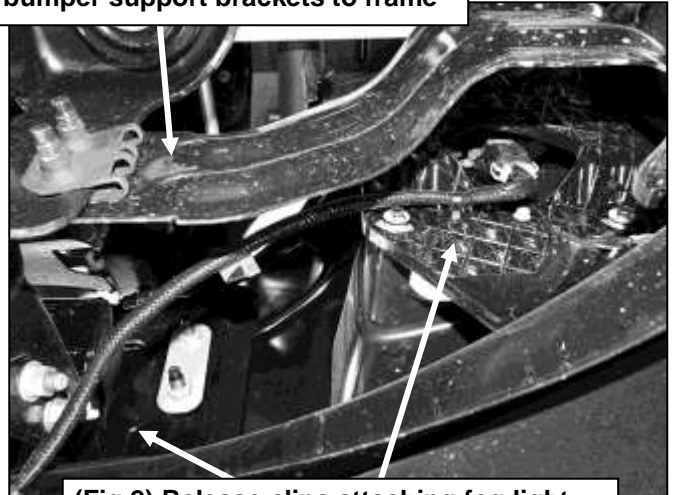

(Fig 2) Release clips attaching fog light wire harness if equipped. Passenger/right side pictured from behind bumper

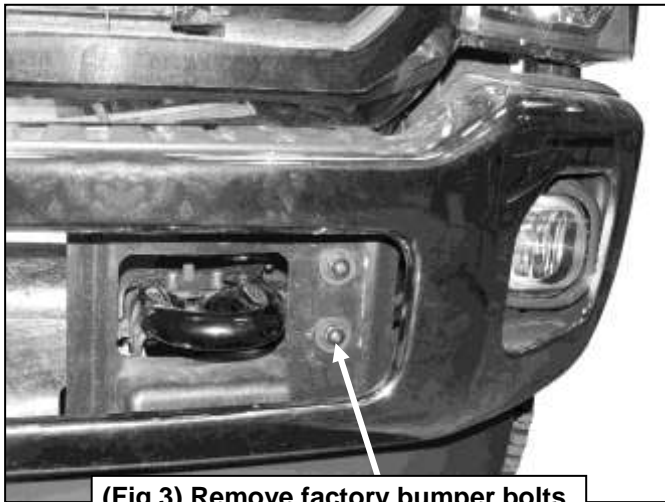

(Fig 3) Remove factory bumper bolts

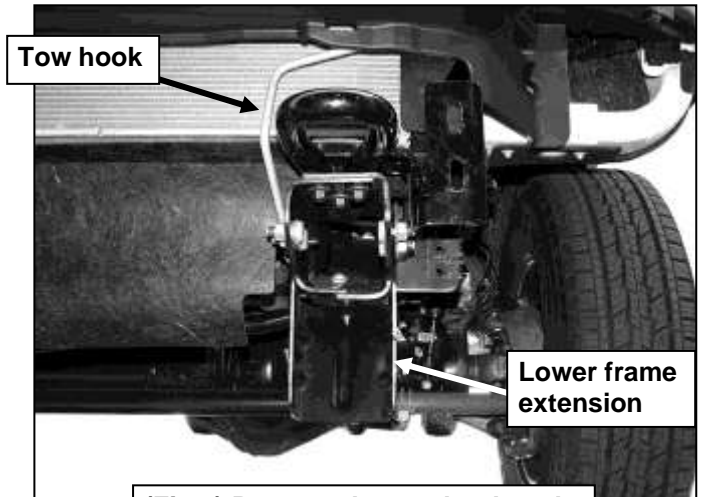

(Fig 4) Remove the tow hook and lower frame extension if equipped

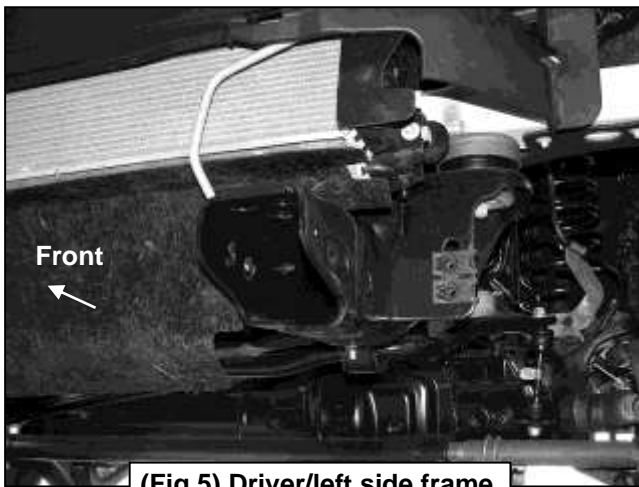

(Fig 5) Driver/left side frame

WARNING! Do not remove bumper bolts unless the bumper is properly supported on blocks or stands or the bumper may fall.

**HD REPLACEMENT WINCH FRONT BUMPER
2011-16 FORD SUPERDUTY F250-350**

Driver Side Installation Pictured

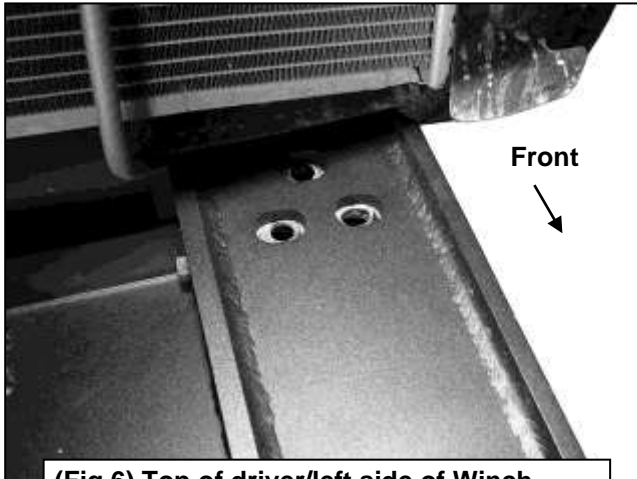

(Fig 6) Top of driver/left side of Winch Tray/Bracket Assembly. Line up mounting holes with holes for tow hook

WARNING! Do not crawl under bumper unless the bumper is properly supported on blocks or stands or the bumper may fall.

- (3) 12mm x 50mm Hex Bolts
- (6) 12mm Flat Washers
- (3) 12mm Lock Washers
- (3) 12mm Hex Nuts

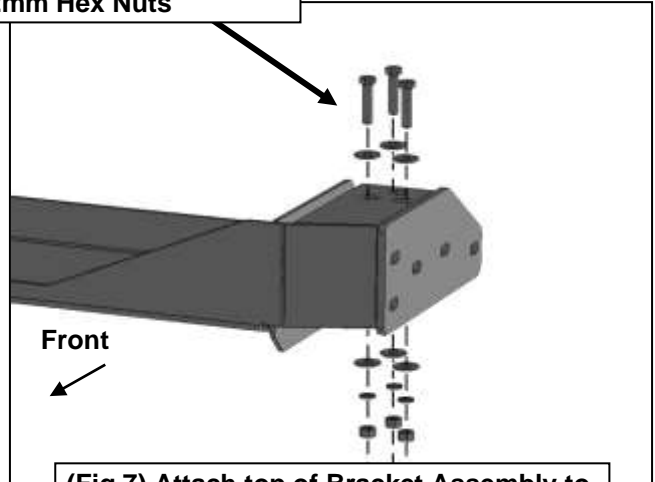

(Fig 7) Attach top of Bracket Assembly to tow hook mounting holes in top of frame

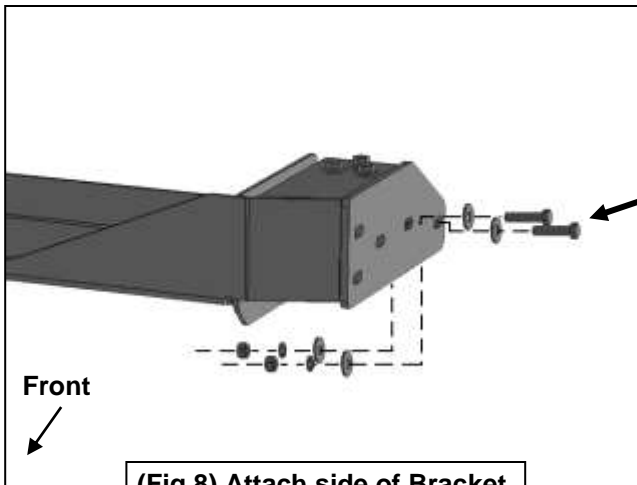

(Fig 8) Attach side of Bracket Assembly to outside of frame

- (2) 12mm x 50mm Hex Bolts
- (4) 12mm Flat Washers
- (2) 12mm Lock Washers
- (2) 12mm Hex Nuts

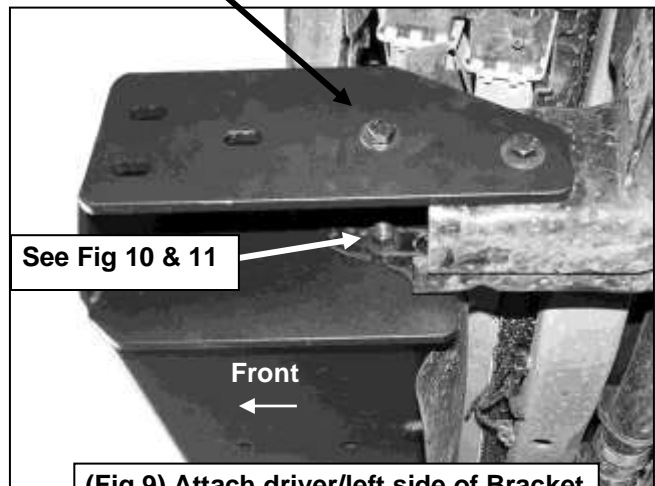

(Fig 9) Attach driver/left side of Bracket Assembly to outside of frame

**HD REPLACEMENT WINCH FRONT BUMPER
2011-16 FORD SUPERDUTY F250-350**

Driver Side Installation Pictured

WARNING! Do not crawl under bumper unless the bumper is properly supported on blocks or stands or the bumper may fall.

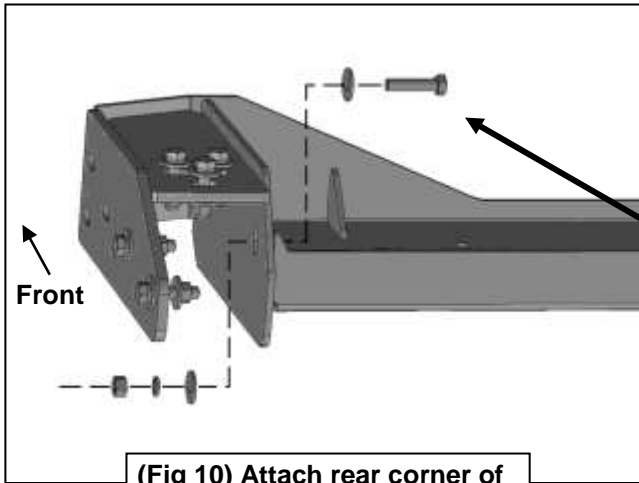

(Fig 10) Attach rear corner of Winch Tray to inside of frame

- 12mm x 50mm Hex Bolt
- (2) 12mm Flat Washers
- 12mm Lock Washer
- 12mm Hex Nut

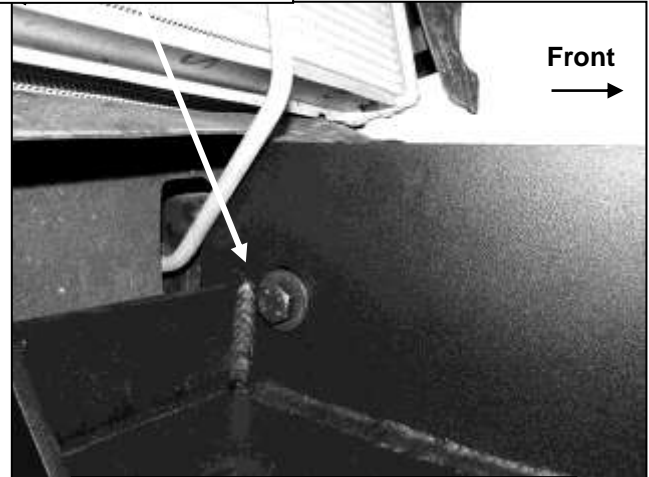

(Fig 11) Driver/left side of Winch Tray

- (3) 12mm x 50mm Hex Bolts
- (6) 12mm Flat Washers
- (3) 12mm Lock Washers
- (3) 12mm Hex Nuts

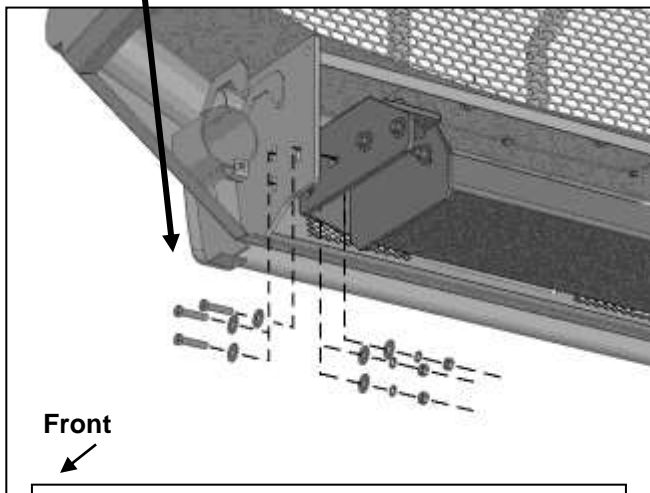

(Fig 12) Attach Bumper to side of Hitch Tray

- (3) 12mm x 50mm Hex Bolts
- (6) 12mm Flat Washers
- (3) 12mm Lock Washers
- (3) 12mm Hex Nuts

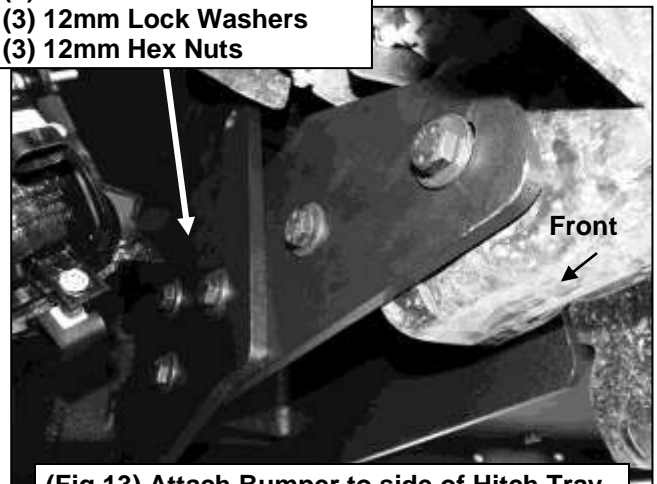

(Fig 13) Attach Bumper to side of Hitch Tray

**HD REPLACEMENT WINCH FRONT BUMPER
2011-16 FORD SUPERDUTY F250-350**

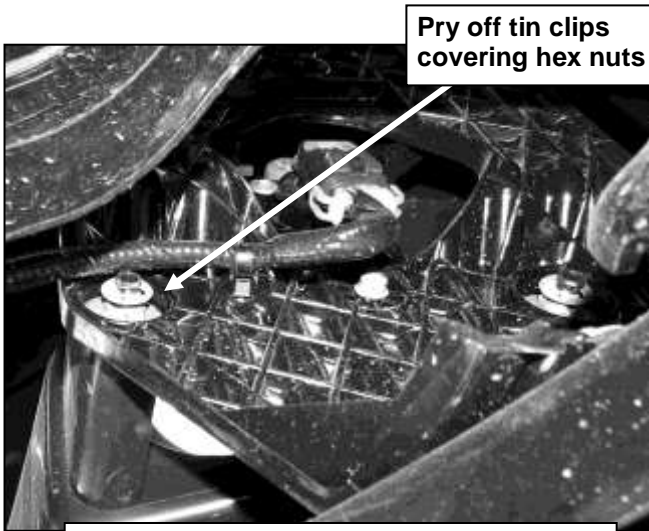

**Pry off tin clips
covering hex nuts**

**(Fig 14) Remove hex nuts to remove
complete fog light assembly with bracket**

- (2) 5mm Screws**
- (4) 5mm Flat Washers**
- (2) 5mm Nylon Lock Nuts**

- Reuse
Factory screw**
- Spring**
- Plastic nut**

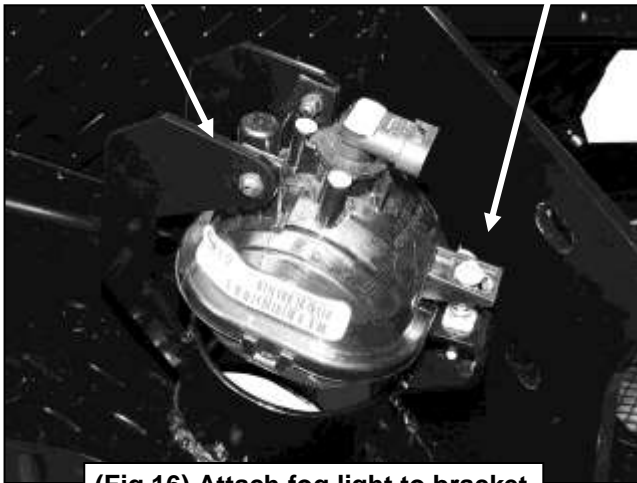

(Fig 16) Attach fog light to bracket

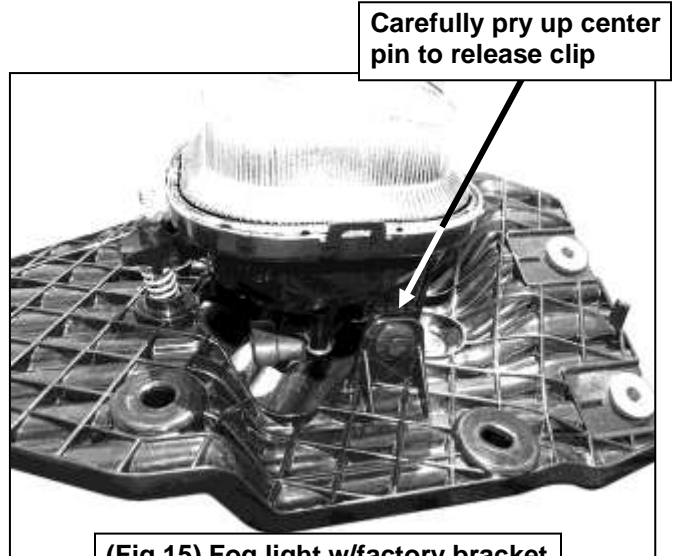

**Carefully pry up center
pin to release clip**

(Fig 15) Fog light w/factory bracket

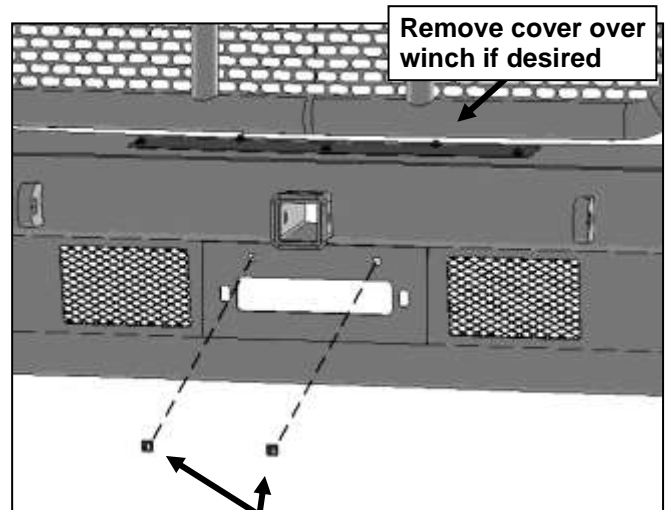

**Remove cover over
winch if desired**

**(Fig 17) Push plastic plugs into holes
in Bumper for license plate if required**