

PARTS LIST:

1	3" Bull Bar	4	12mm Hex Nuts
1	Driver/Left Frame Mounting Bracket	2	10-1.50mm x 120mm x 30mm Hex Bolts
1	Passenger/Right Frame Mounting Bracket	2	10mm x 30mm OD x 2.5mm Flat Washers
4	Large Spacer Washers	2	10mm Lock Washers
4	12-1.75mm x 35mm Hex Bolts	2	10mm Hex Nuts
8	12mm x 37mm OD x 3mm Flat Washers	1	Universal Wiring Harness
4	12mm Lock Washers		

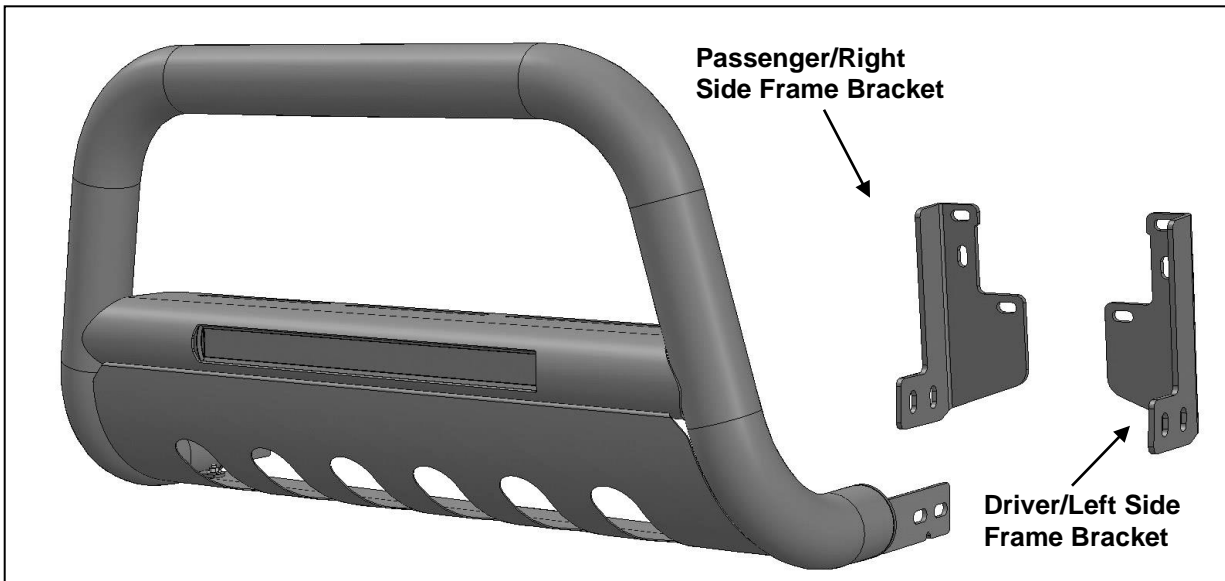

PROCEDURE:

- REMOVE CONTENTS FROM BOX. VERIFY ALL PARTS ARE PRESENT. READ INSTRUCTIONS CAREFULLY BEFORE STARTING INSTALLATION. NOT COMPATIBLE WITH OPTIONAL FULL COVERAGE FACTORY ALUMINUM SKID PLATE. OPTIONAL SKID PLATE MUST BE REMOVED AND CANNOT BE REINSTALLED.**
- Start installation at the passenger side, front of the vehicle. Remove the (2) outer factory hex nuts attaching the bumper mount to the end of the frame, **(Figure 1)**. **NOTE:** It may be necessary to temporarily remove the factory tow hook from the passenger side.
- Select the passenger side frame mounting bracket. Slide the Bracket over the (2) threaded studs. Secure the Bracket to the studs with the factory hex nuts, **(Figures 2 & 6)**. Leave hardware loose.
- Slide (1) Large Spacer Washer between the Mounting Bracket and the frame cross member, **(Figures 3A & 3B)**. Insert (1) 10mm x 120mm Hex Bolt with (1) 10mm Flat Washer and (1) Large Spacer Washer into and through the hole in the back of the cross member. Make sure the Spacer Washer is against the cross member covering the large hole, **(Figures 4 & 6)**. Push the long bolt through the outer Spacer Washer and Frame Bracket. Secure the Bracket to the Bolt with (1) 10mm Flat Washer, (1) 10mm Lock Washer and (1) 10mm Hex Nut, **(Figures 5 & 6)**. Leave hardware loose at this time.
- Repeat **Steps 2—4** for driver side Bracket installation.
- Next, carefully unwrap the Bull Bar. With assistance, line up the mounting tabs on the Bull Bar with the outside of the (2) previously installed Frame Mounting Brackets. Bolt the Bull Bar to the Frame Mounting Brackets with the included (4) 12mm x 35mm Hex Bolts, (8) 12mm Flat Washers, (4) 12mm Lock Washers and (4) 12mm Hex Nuts, **(Figure 7)**. Snug but do not tighten hardware at this time.
- Level and adjust the Bull Bar properly and tighten all hardware. Reinstall the tow hook if removed.
- LED Light is preinstalled in Bull Bar. Verify that light is properly installed. **NOTE:** Use slots in top plate on Bull Bar to attach additional lights as desired, **(Figure 8)**.
- Open hood and disconnect the battery.
- Unwrap preassembled wiring harness, **(Figure 9)**. Disconnect the plug in the harness leading to the lighted switch. Locate suitable mounting location for switch. Drill 3/4" hole in panel to mount switch.

IMPORTANT: Do not drill any holes in panel until back of mounting location is properly checked for clearance. Use of safety goggles is required.

11. Run switch harness through firewall on vehicle. Drill hole through firewall as required for harness plug. Highly recommend use of rubber grommet (not included) to protect harness. Feed switch harness plug through hole in firewall. Seal firewall with silicone as necessary.
12. Attach Relay and main harness to suitable location near battery but away from heat source, (firewall or inner fender for example). Do not connect to battery at this time.
13. Attach switch plug to switch harness and tie harness away from anything that could damage harness.
14. Run the prewired light harness down to the light. Plug harness into prewired plug on light. Tie wiring harness away from anything that could damage harness.
15. Attach the fused red positive and black negative wires on the main harness to the battery. **NOTE:** Attach black negative wire to negative terminal on battery or suitable chassis ground.
16. Reattach battery cables to battery. Adjust Light for optimum visibility as necessary. Fully tighten all hardware including light mounting hardware. Installation is complete.
17. Do periodic inspections to the installation to make sure that all hardware is secure and tight and all wiring harnesses are properly secured and free from excessive movement.

To protect your investment, wax this product after installing. Regular waxing is recommended to add a protective layer over the finish. Do not use any type of polish or wax that may contain abrasives that could damage the finish.

For stainless steel: Aluminum polish may be used to polish small scratches and scuffs on the finish. Mild soap may be used also to clean the Bull Bar.

For gloss black finishes: Mild soap may be used to clean the Bull Bar.

Passenger Side Installation Pictured

Remove (2) factory hex nuts on outside of frame

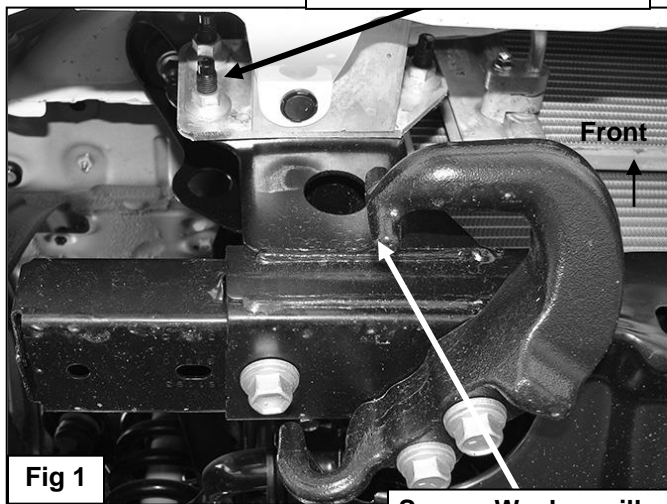

Spacer Washer will cover this opening in the end of the frame

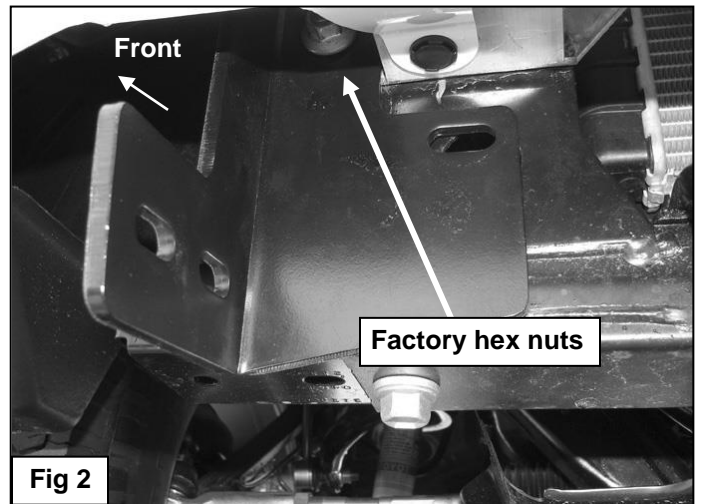

Passenger Side Installation Pictured

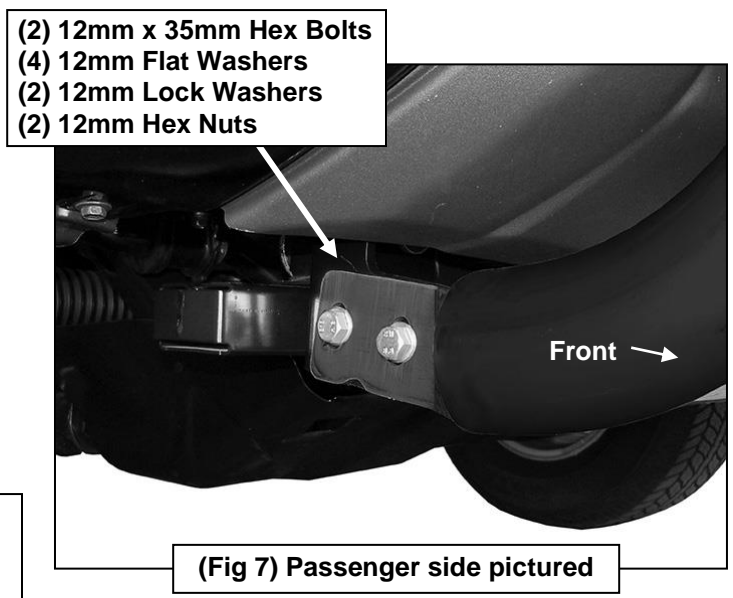
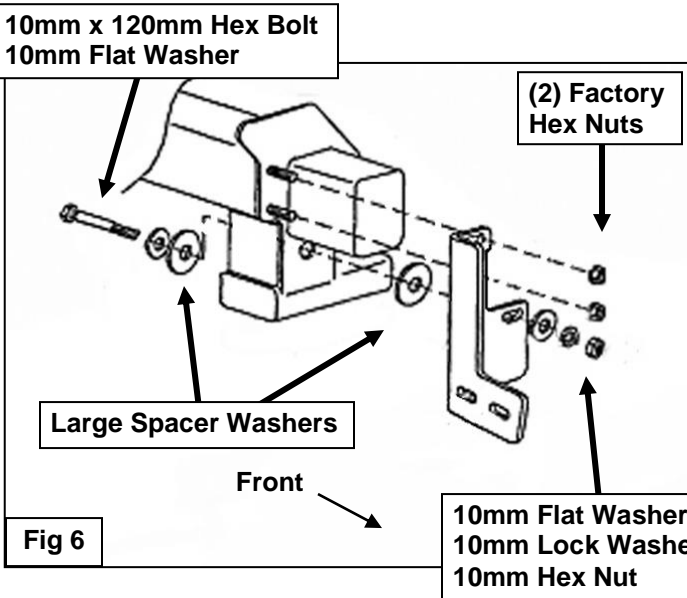
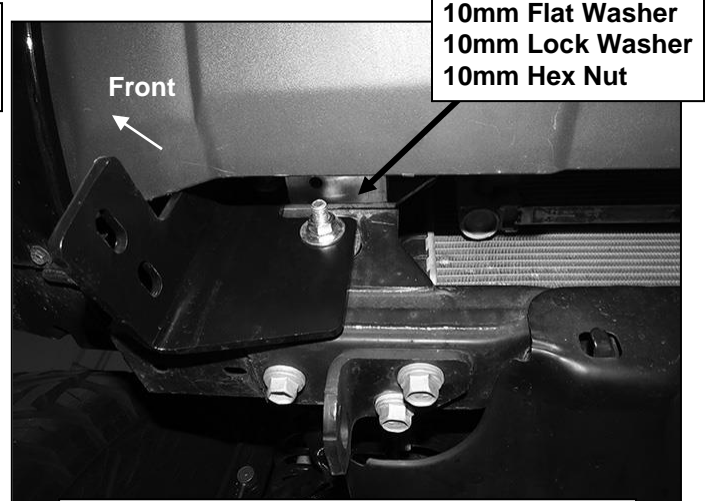
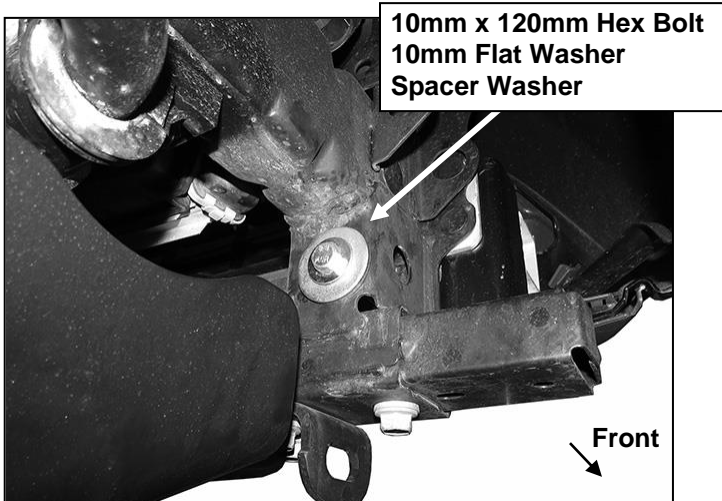
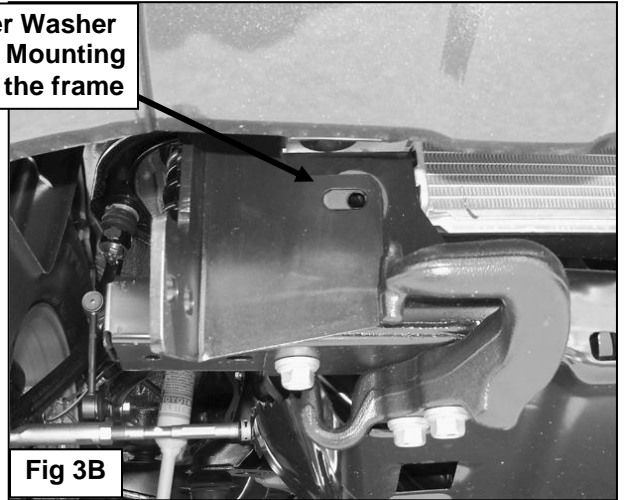
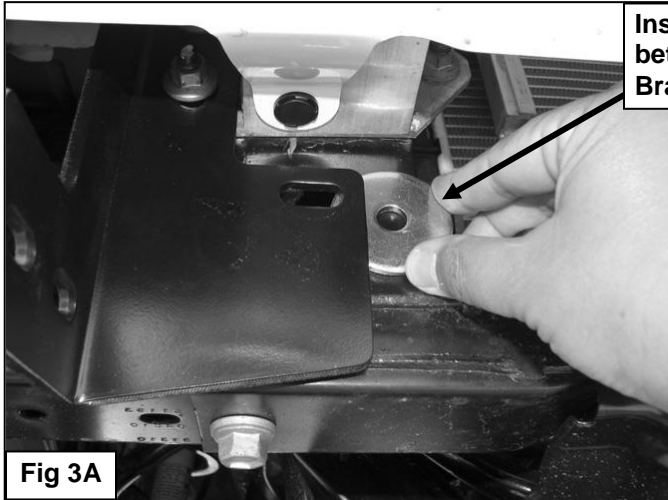

Passenger Side Installation Pictured

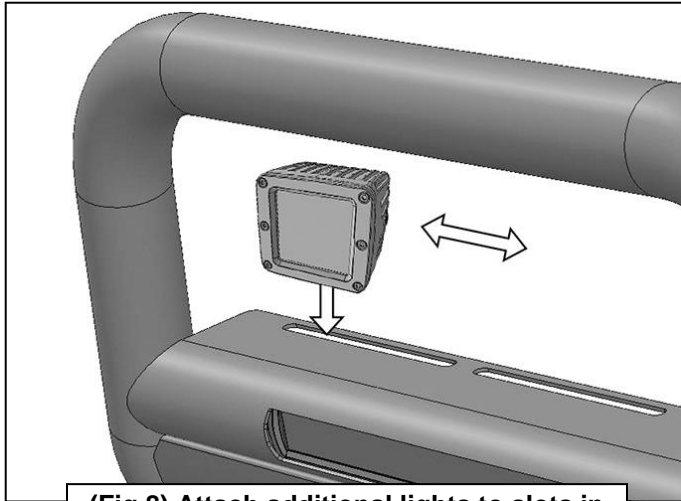

(Fig 8) Attach additional lights to slots in top plate (lights and wiring not included)



Lighting laws vary state to state. Check applicable local laws before using any accessory lighting. **IMPORTANT:** Adjust lights away from oncoming vehicles. Do not operate lights in the proximity of oncoming traffic.

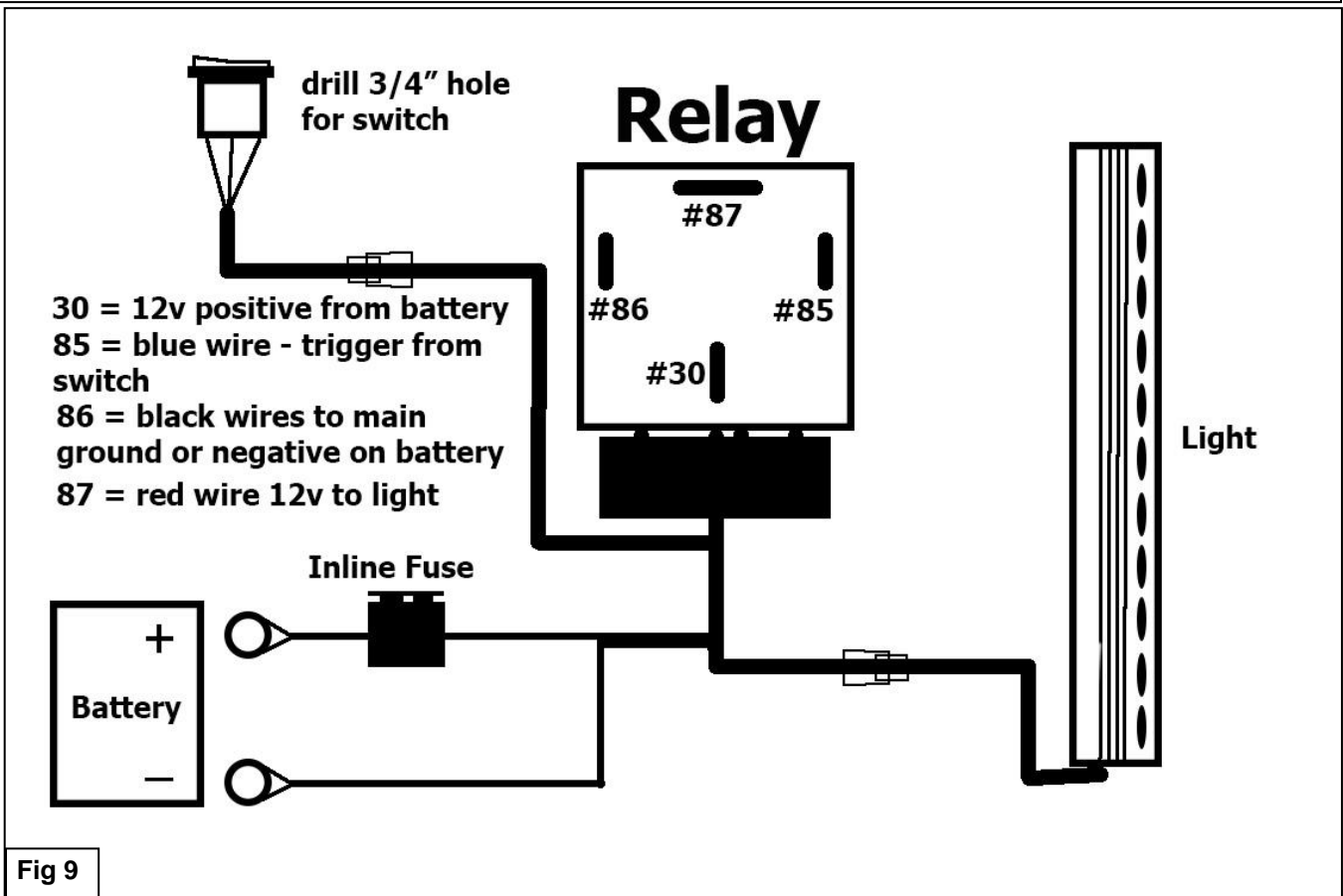

Fig 9