

# INSTALLATION INSTRUCTIONS

**FORTIS REAR BUMPER  
2015-18 FORD F150**

FORTIS REAR BUMPER  
2015-18 FORD F150

## PARTS LIST:

1	Fortis Rear Bumper Assembly	1	Sensor Cover Kit
1	Driver/left Mounting Bracket	4	10-1.5mm x 40mm Hex Bolts
1	Passenger/right Mounting Bracket	8	10mm x 30mm x 2.5mm Flat Washers
2	Plastic Plugs for license plate mount	4	10mm Lock Washers
4	Sensor Hole Plugs	4	10mm Hex Nuts
4	Sensor Retaining Rings	8	4mm x 10mm Button Head Bolts
4	Foam 20mm x 10mm Spacer Washers	1	2.5mm Wrench
4	Foam 15.5mm x 25mm x 2mm Sealing Washers		

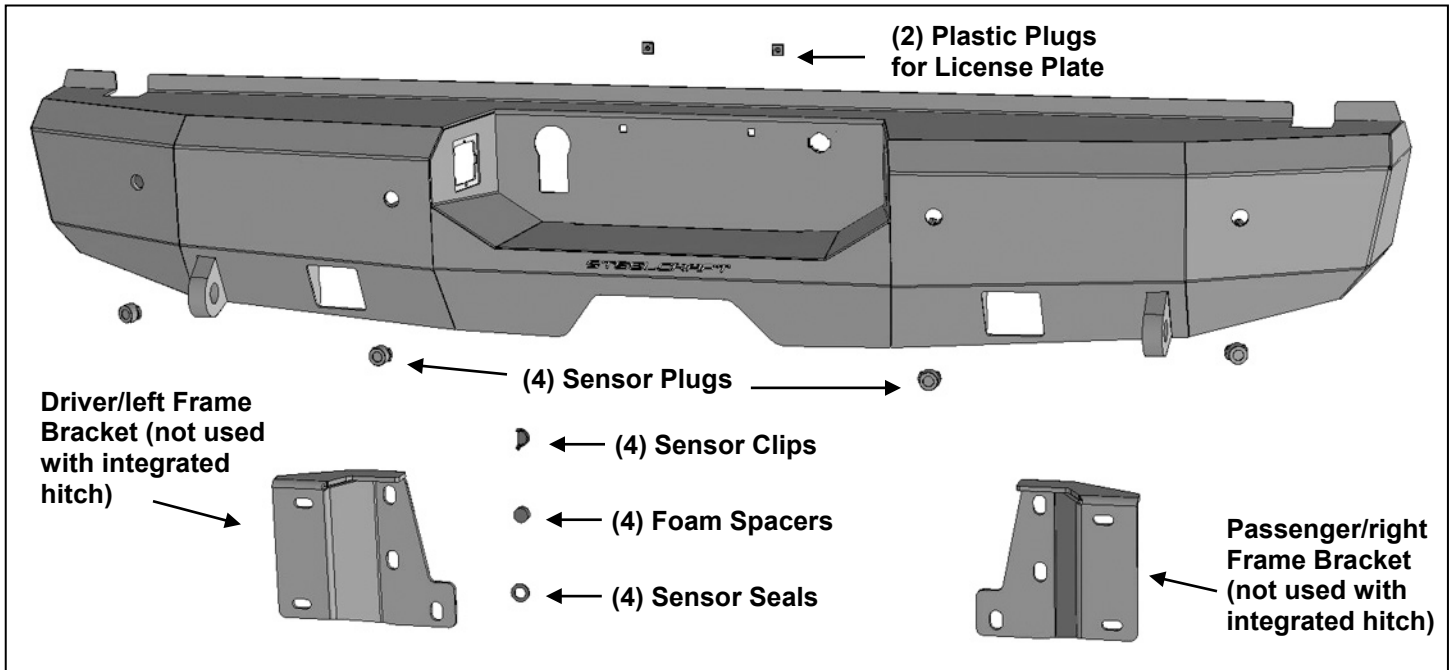

## PROCEDURE:

**REMOVE CONTENTS FROM BOX. VERIFY ALL PARTS ARE PRESENT. READ INSTRUCTIONS CAREFULLY BEFORE STARTING INSTALLATION. BUMPER IS HEAVY, ASSISTANCE IS RECOMMENDED TO AVOID POSSIBLE INJURY OR DAMAGE TO THE VEHICLE.**

**IMPORTANT: OEM BUMPER REINFORCEMENT USED WITH "STANDARD" TOW PACKAGE WITHOUT RECEIVER HITCH CANNOT BE REINSTALLED. OE INTEGRATED "HD" HITCH, "MAX DUTY" HITCH AND MOST AFTERMARKET RECEIVER HITCHES REQUIRED FOR TOWING.**

1. Remove the license plate from the bumper, (**Figure 1**). Unplug the wiring harness leading to the bumper and move harness away from bumper, (**Figure 2**). **NOTE:** Steelcraft Bumper is designed to be compatible with larger 7-wire universal trailer harness plug only.
2. Place blocks or jack stands under the bumper to support it during mounting bolt removal. Once the bumper has been safely supported, remove the factory hardware attaching the bumper to the end of the frame and remove the bumper assembly, (**Figures 3A, 3B & 4**). Models equipped with std tow package with bumper reinforcement only or "HD integrated" hitch can remove hitch and bumper together. Models equipped with "Max Duty" receiver hitch, (**Figure 5**), leave hitch in place on frame and remove bumper assembly only. **WARNING!** Assistance is required to hold the bumper in place during hardware removal to prevent bumper from falling.
3. Remove sensors, (if equipped), from bumper. Release the clips securing the trailer plug and remove the plug, (**Figure 1**). Remove the license plate lights and wiring harness from the bumper, (**Figure 2**). Next, remove the spare tire plug lock if equipped.
4. Determine if the vehicle is equipped with sensors. **NOTE:** Depending on tow package, (**Figures 5 & 12**), it may be necessary or easier to install sensors, (if equipped), and harness before installing the Bumper.

**Models without bumper sensors:**

- a. Select the included (4) Rubber Plugs, **(Figure 6)**.
- b. From behind bumper, push plugs into sensor mounting sleeves, **(Figure 6)**. Screws have been provided to lock the plugs into the sleeves. Use is optional.

**Models with bumper mounted sensors:**

- a. Select (1) sensor. Remove the seal from the end of the sensor. Slide the included larger Sensor Seal over front of the sensor, **(Figure 7)**.
  - b. Insert the sensor with Seal into sensor mount, **(Figure 8)**.
  - c. Place thick Foam Spacer over end of the sensor. Push Sensor Retaining Clip into sensor mount and lock into mounting holes, **(Figure 8)**.
  - d. Repeat previous Steps to install remaining sensors.
  - e. Install wiring harness for sensors and plug harness into sensors and/or trailer plug.
  - f. **Optional:** Secure each sensor to the socket with (2) 4mm x 10mm Button Head Screws.  
**IMPORTANT:** Sensors fit snug in sockets. The 4mm Screws are used to apply slight pressure to lock the sensors in place. Tighten both screws evenly until they touch the sensor body only. Do not overtighten screws or damage to sensors will result.
5. Attach the wiring harness to the sensors, lights and trailer plug as equipped.
  6. Use a small flat blade screwdriver to pry the star washers off of the bolt plates used to attach the factory bumper to the frame, **(Figure 9)**. **NOTE:** "HD" tow package models use a triple bolt plate, "Standard" and "Max Duty" equipped models use a double bolt plate, **(Figure 10)**.
  7. **Determine towing package supplied with vehicle:**  
**Models with "standard tow package" without HD receiver below bumper and models with "Max Duty" frame mounted receiver hitch below bumper, (Figure 5).**
    - a. Reuse the factory bolt plate and hardware to attach the passenger/right Mounting Bracket to the end of the frame, **(Figure 10)**. Repeat to attach the driver/left Mounting Bracket to the frame.
    - b. With assistance, hold the Bumper assembly up to the Brackets. Temporarily support the weight of the Bumper. **WARNING:** To avoid possible injury or damage to the vehicle, do not proceed until the bumper is fully and safely supported.
    - c. Attach the passenger/right side of the Bumper to the Bracket with (2) 10mm x 40mm Hex Bolts, (4) 10mm Flat Washers, (2) 10mm Lock Washers and (2) 10mm Hex Nuts, **(Figure 11)**. Snug but do not fully tighten hardware at this time. Repeat to attach the driver/left side of the Bumper to the Bracket.
    - d. Skip to **Step 8**.**Models with "HD" tow package with integrated receiver hitch in bumper and brackets.**
    - a. Remove integrated receiver hitch and bracket assembly from back of bumper.
    - b. Reuse factory hardware to reinstall receiver/bumper bracket assembly to mounts on ends of frame, **(Figure 12)**. Snug but do not fully tighten hardware at this time.
    - c. With assistance, attach the passenger/right side of the Bumper directly to the receiver/bumper bracket assembly with (2) 10mm x 40mm Hex Bolts, (4) 10mm Flat Washers, (2) 10mm Lock Washers and (2) 10mm Hex Nuts, **(Figure 13)**. Temporarily support the weight of the Bumper. Repeat to attach the driver/left side of the Bumper assembly. **WARNING:** To avoid possible injury or damage to the vehicle, do not proceed until the bumper is fully and safely supported. Snug but do not fully tighten hardware at this time. Continue to **Step 8**.
  8. Level and adjust the bumper and slowly lower the tailgate and check for clearance. Adjust the bumper as required and fully tighten all hardware to 65-70ft-lbs.
  9. Do periodic inspections to the installation to make sure that all hardware is secure and tight.
  10. Use the included (2) push-in plugs to attach the license plate to the Bumper, **(Figures 14 & 15)**. Reinstall the spare tire hole plug lock, license plate lights and trailer plug into the Fortis Bumper. **NOTE:** Use a flat blade screwdriver to carefully pry out the metal clips on the trailer plug to grab the edge of the opening if necessary.
  11. Plug in the wiring harness on the bumper to the main harness on the vehicle.
  12. Do periodic inspections to the installation to make sure that all hardware is secure and tight.

**FORTIS REAR BUMPER  
2015-18 FORD F150**

**To protect your investment,** Do not use any type of polish or wax that may contain abrasives that could damage the finish. Mild soap may be used to clean the Bumper assembly.

**Passenger Side Installation Pictured**



**(Fig 1) Unplug and remove 7-wire trailer plug**



**(Fig 2) Unplug and remove license plate lights**

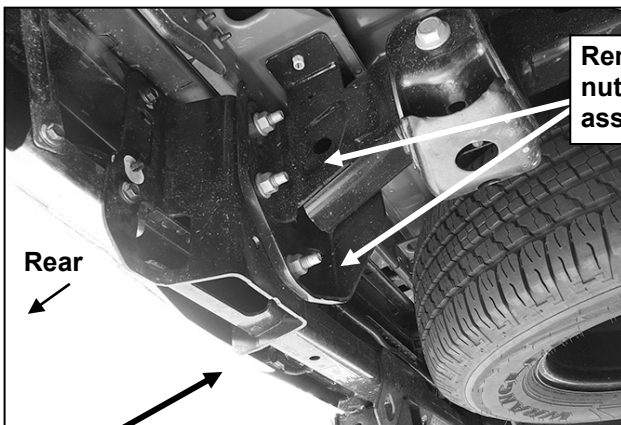

**Remove the factory hex nuts attaching bumper assembly to frame**

**(Fig 3A) Note bumper with integrated receiver hitch**

**WARNING!** Do not crawl under bumper unless the bumper is properly supported on blocks or stands or the bumper may fall.



**(Fig 3B) Remove the factory hex nuts attaching bumper assembly to frame. STD tow package model pictured (no receiver hitch)**

Passenger Side Installation Pictured

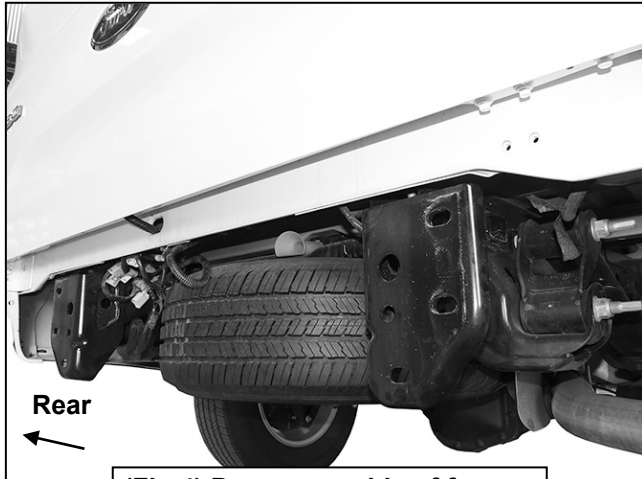

(Fig 4) Passenger side of frame

**WARNING!** Do not remove bumper bolts unless the bumper is properly supported on blocks or stands or the bumper may fall.

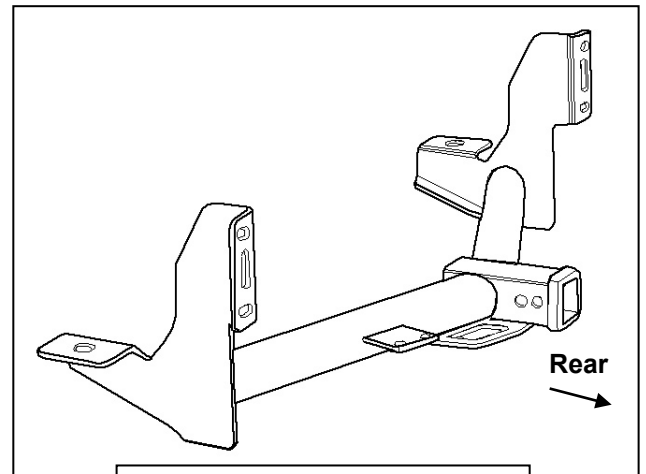

(Fig 5) Example of "Max Duty" OE style receiver hitch

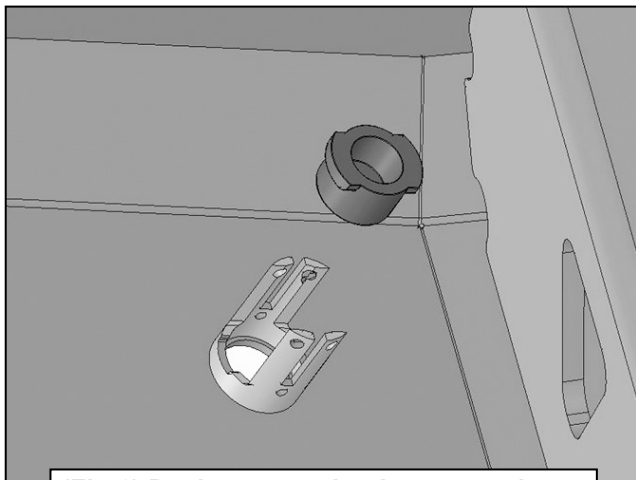

(Fig 6) Push sensor plug into mounting sleeve. Use of 4mm Screws is optional

**NOTE:** Sensor plugs fit snug in sockets. Use of the 4mm Screws is optional. 4mm Screws can also be used to apply slight pressure to lock the sensors in place or to aim the sensor. Tighten both screws evenly until they touch the sensor body only. Do not overtighten screws or damage to sensors will result.

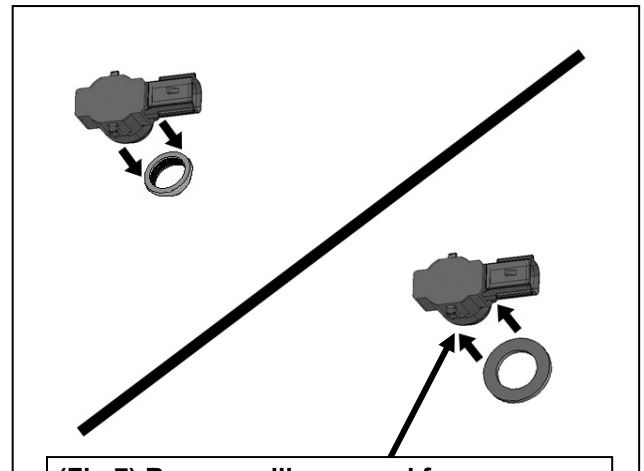

(Fig 7) Remove silicone seal from sensor. Slide large Seal over end of sensor (arrow)

Passenger Side Installation Pictured

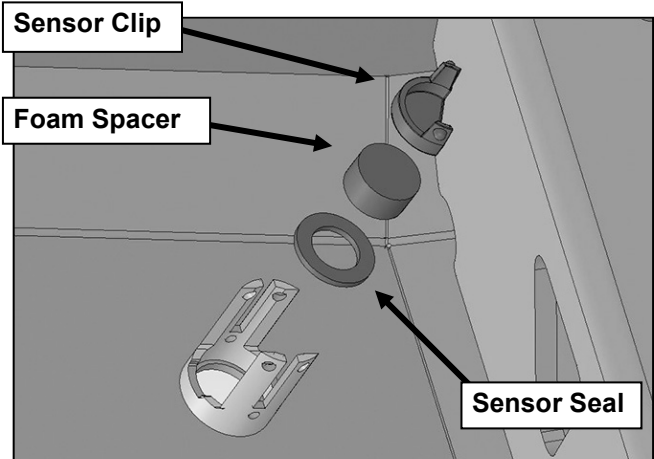

(Fig 8) Slide sensor into sleeve, insert Foam Spacer and Clip to lock sensor in sleeve

**WARNING!** Do not crawl under bumper unless the bumper is properly supported on blocks or stands or the bumper may fall.

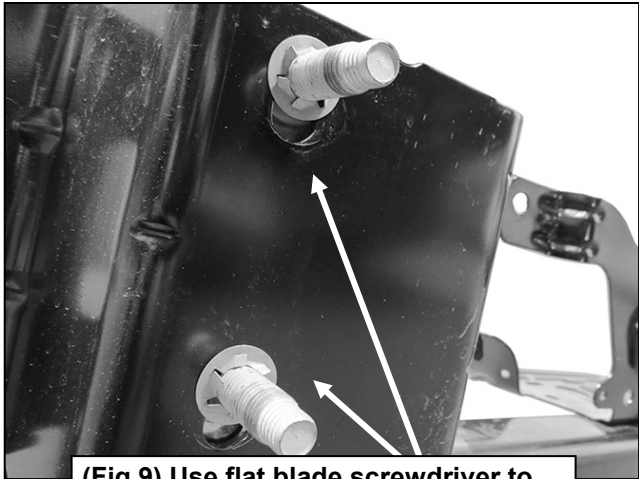

(Fig 9) Use flat blade screwdriver to pry off lock washers from bolt plates

Factory triple bolt plate used with "HD tow" package with integrated receiver hitch

Factory double bolt late used on model w/o receiver hitch and "max tow" frame mounted receiver hitch

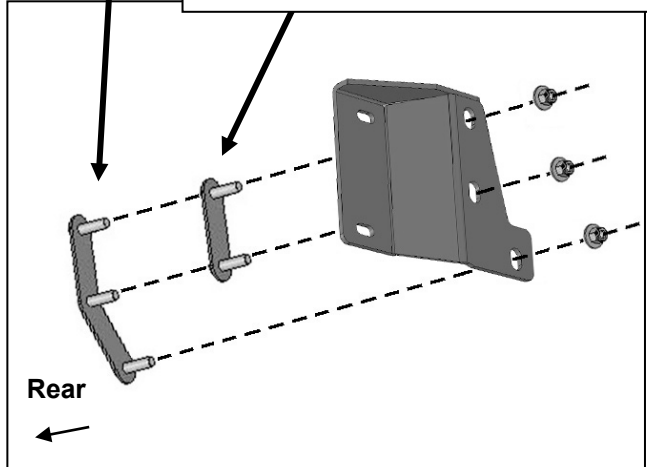

(Fig 10) Reuse either factory bolt plate to attach passenger/right Mounting Bracket to end of frame

- (2) 10mm Flat Washers
- (2) 10mm Nylon Lock Nuts

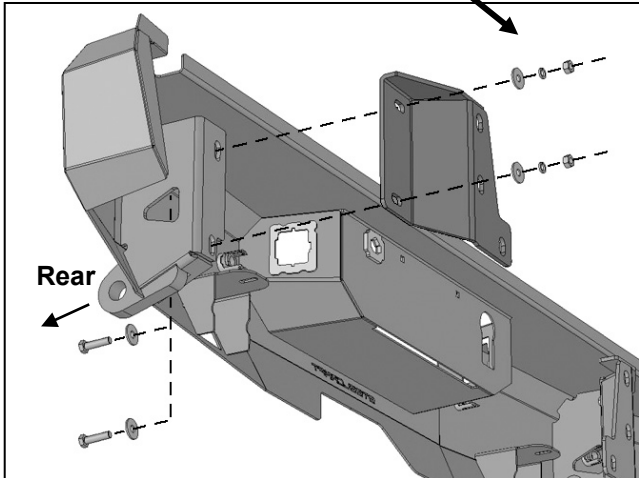

(Fig 11) Insert 10mm Double Bolt Plate into and through back of mounting tab on back of Bumper

Passenger Side Installation Pictured



(Fig 12) Reinstall integrated receiver hitch/bracket assembly on models with "HD Towing" package

**WARNING!** Do not crawl under bumper unless the bumper is properly supported on blocks or stands or the bumper may fall.

(2) 10mm Flat Washers  
(2) 10mm Nylon Lock Nuts

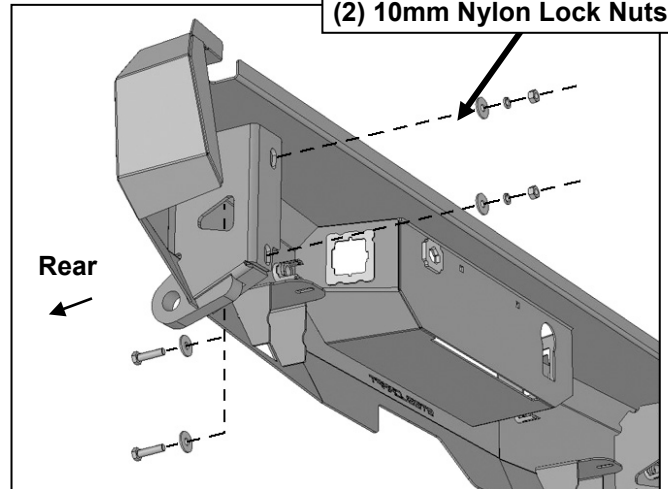

(Fig 13) Attach Bumper directly to integrated hitch bracket (see Fig 12)

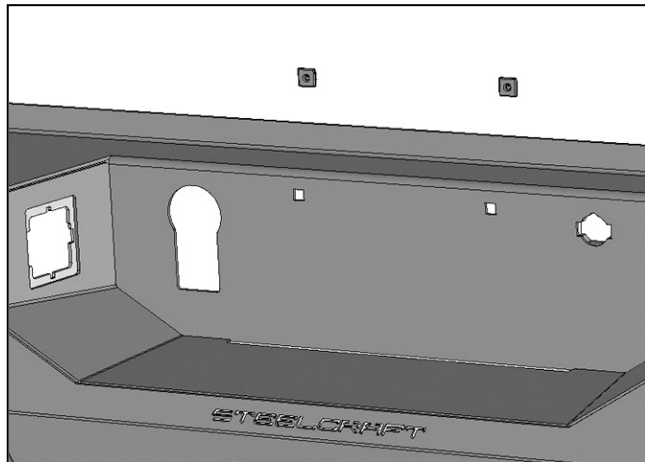

(Fig 14) Push plastic plugs into holes for license plate

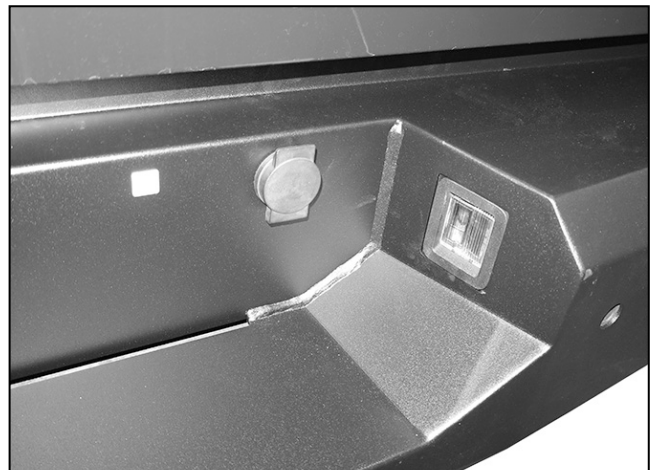

(Fig 15) Install spare tire access lock (if equipped)



Complete Installation