

PARTS LIST:

1	3" Bull Bar	4	10mm Lock Washers
1	Driver/Left Mounting Bracket	2	10mm Plastic Retainers
1	Passenger/Right Mounting Bracket	2	10mm Hex Nuts
2	10mm Bolt/10mm Nut plates	4	8-1.25mm x 35mm Hex bolts
4	10-1.5mm x 35mm Hex Bolts	4	8mm x 24mm x 2mm Flat Washers
4	10mm x 30mm OD x 2.5mm Flat Washers	4	8mm Lock Washers
		1	Allen Wrench S=4

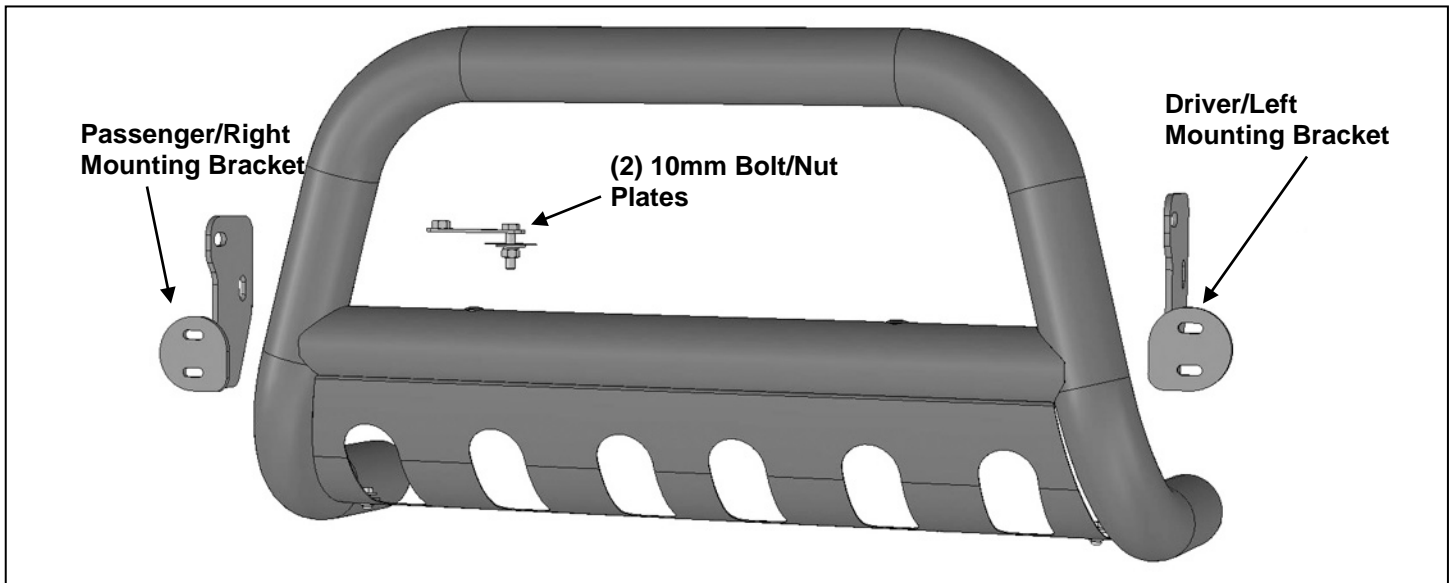

PROCEDURE:

- 1. REMOVE CONTENTS FROM BOX. VERIFY ALL PARTS ARE PRESENT. READ INSTRUCTIONS CAREFULLY. CUTTING IS REQUIRED. ASSISTANCE IS RECOMMENDED.**
- Remove the plastic splash guard from under the front bumper and place it on a clean, stable work surface, **(Figures 1 & 5)**. Models with steel skid plate, skid plate must be removed and cannot be reinstalled.

Models with plastic splash guard:

- Starting on the passenger/right side, locate the lower hex shaped hole in the outside of the frame, **(Figure 2)**. Insert (1) 10mm Bolt/Nut Plate, (end with welded nut first), into the open end of the bottom of the frame and push the welded hex bolt through the hex shaped hole, **(Figure 3)**. Thread (1) 10mm Plastic Retainer onto the Bolt/Nut Plate to hold it in position. **NOTE:** Plastic Retainer is designed to hold the Bolt Plate in position to help with Bracket installation. Use is not mandatory. **IMPORTANT:** Remove the steel frame bracket for the splash guard if more room is necessary to install the Bolt/Nut Plate, **(Figure 1)**.
- Select the passenger/right side Mounting Bracket, **(Figure 4)**. Attach the Bracket to the Bolt on the Bolt Nut Plate with (1) 10mm Flat Washer, (1) 10mm Lock Washer and (1) 10mm Hex Nut. Leave loose at this time. Grab the threaded end of the 10mm Bolt/Nut Plate and rotate it until the top end with the welded Nut lines up with the round hole in the outside of the frame and the top mounting hole in the Bracket. Attach the Bracket to the Bolt/Nut Plate with (1) 10mm x 35mm Hex bolt, (1) 10mm Lock Washer and (1) 10mm Flat Washer, **(Figures 4 & 7)**. Snug but do not fully tighten Bracket hardware at this time. Reinstall the steel frame bracket for the splash guard if previously removed.

Models with steel skid plate:

- a. Select the passenger/right side Mounting Bracket. Attach the Bracket to the lower threaded hole in the outside of the frame with (1) 10mm x 35mm Hex bolt, (1) 10mm Lock Washer and (1) 10mm Flat Washer, **(Figure 4)**. Do not tighten.
- b. Repeat the previous Steps to install the Bolt/Nut Plate into the open end of the frame and up to the top mounting hole, **(Figure 2)**. Attach the top of the Bracket to the Nut end on the Bolt /Nut Plate with (1) 10mm x 35mm Hex bolt, (1) 10mm Lock Washer and (1) 10mm Flat Washer. Snug but do not fully tighten Bracket hardware at this time.
3. Repeat the appropriate **Step 2** for driver/left side Mounting Bracket installation.
4. Position the splash guard back up to the vehicle and temporarily attach with the factory hardware. Trace the location of the Mounting Brackets onto the back of the splash guard, **(Figure 5)**. Remove the splash guard and move it to a clean stable work surface. Carefully cut openings in the splash guard to clear the Bull Bar. **NOTE:** To maintain the integrity of the plastic Splash Guard, remove only material necessary to clear the Bull Bar and Brackets. Make small cuts and check the fit often before final installation.
5. Reinstall the splash guard with factory hardware.
6. With assistance, position the Bull Bar up to the Mounting Brackets. Use the included (4) 8mm x 35mm Hex Bolts, (4) 8mm Lock Washers and (4) 8mm Flat Washers to attach the Bull Bar to the Mounting Brackets, **(Figures 6 & 7)**. Do not tighten hardware at this time.
7. Align the Bull Bar properly and fully tighten all hardware.
8. Do periodic inspections to the installation to make sure is secure and tight.

To protect your investment, wax this product after installing. Regular waxing is recommended to add a protective layer over the finish. Do not use any type of polish or wax that may contain abrasives that could damage the finish.

For stainless steel: Aluminum polish may be used to polish small scratches and scuffs on the finish. Mild soap may be used also to clean the Bull Bar.

For gloss black finishes: Mild soap may be used to clean the Bull Bar.

Passenger/Right Side Installation Pictured



(Fig 1) Remove splash guard and bracket (arrow)

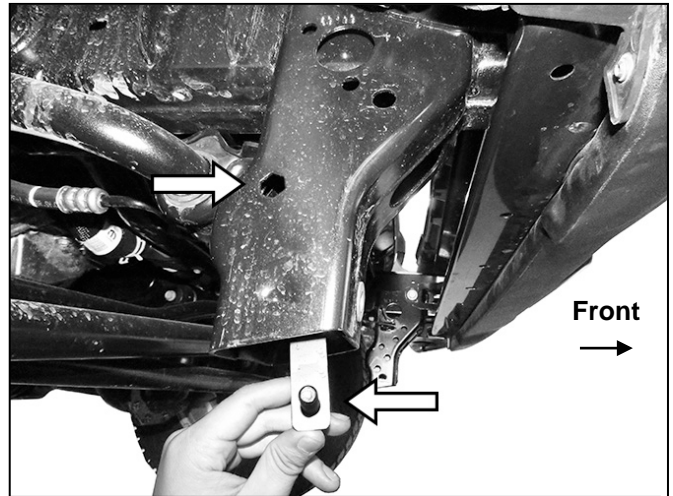

(Fig 2) Insert 10mm Bolt/Nut Plate into bottom of frame and out hex hole in side of frame (arrows)



(Fig 3) Use Retainer to hold 10mm Bolt/Nut Plate

10mm x 35mm Hex Bolt
10mm Lock Washer
10mm Flat Washer

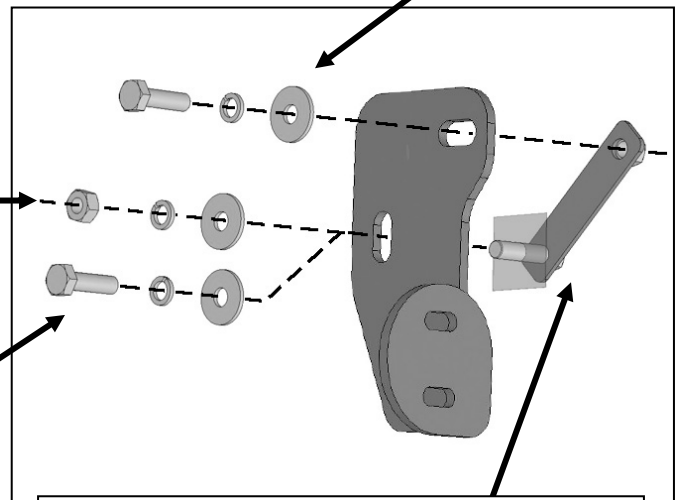

(Fig 4) Attach passenger/right Mounting Bracket to 10mm Bolt/Nut Plate and Retainer

Models with plastic splash guard
10mm Hex Nut
10mm Lock Washer
10mm Flat Washer

Models with steel skid plate use
10mm Hex Nut
10mm Lock Washer
10mm Flat Washer

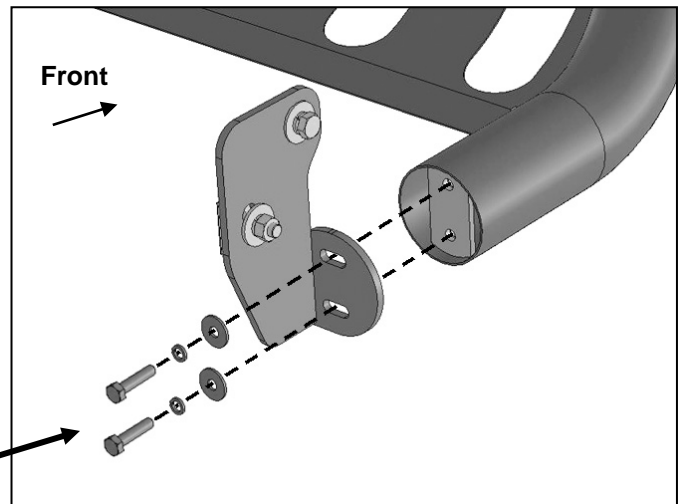
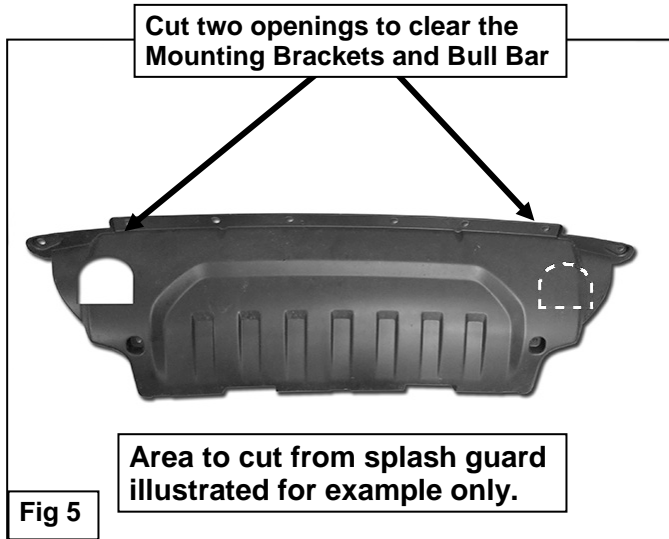

- (2) 8mm x 35mm Hex Bolts
- (2) 8mm Lock Washers
- (2) 8mm Flat Washers

(Fig 6) Attach end of Bull Bar to passenger/right Mounting Bracket

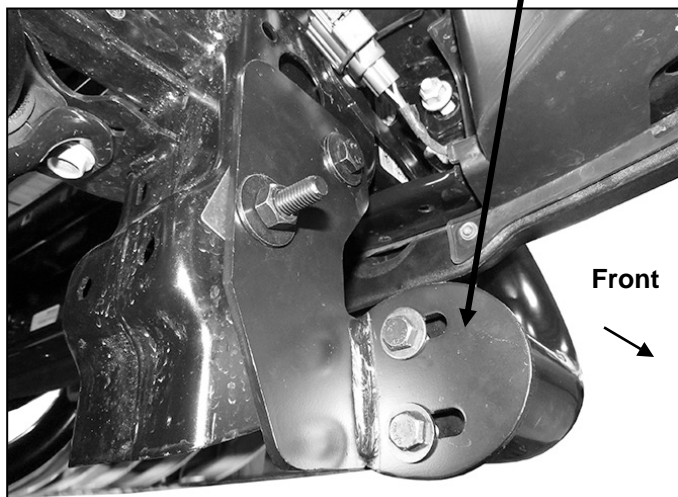

(Fig 7) Attach end of Bull Bar to passenger/right Mounting Bracket. Pictured without splash guard for instruction purposes only