



INSTALLATION INSTRUCTIONS

**FORTIS FRONT BUMPER
2011-16 FORD SUPERDUTY F250-350**

**FORTIS FRONT BUMPER
2011-16 FORD SUPERDUTY F250-350**

PARTS LIST:

1	Front Bumper Assembly	16	12mm Lock Washers
1	Driver/left side Bracket	16	12-1.75mm Hex Nuts
1	Passenger/right side Bracket	2	8-1.25mm x 25mm Hex Bolts
1	Driver/left side Light Bar "L" Bracket	2	8-1.25mm x 16mm Hex Bolts
1	Passenger/right side Light Bar "L" Bracket	6	8mm x 24mm x 2mm Flat Washers
2	License Plate Plastic Plugs	4	8mm Lock Washers
16	12-1.75mm x 50mm Hex Bolts	2	8mm Hex Nuts
32	12mm x 32mm x 3mm Flat Washers		

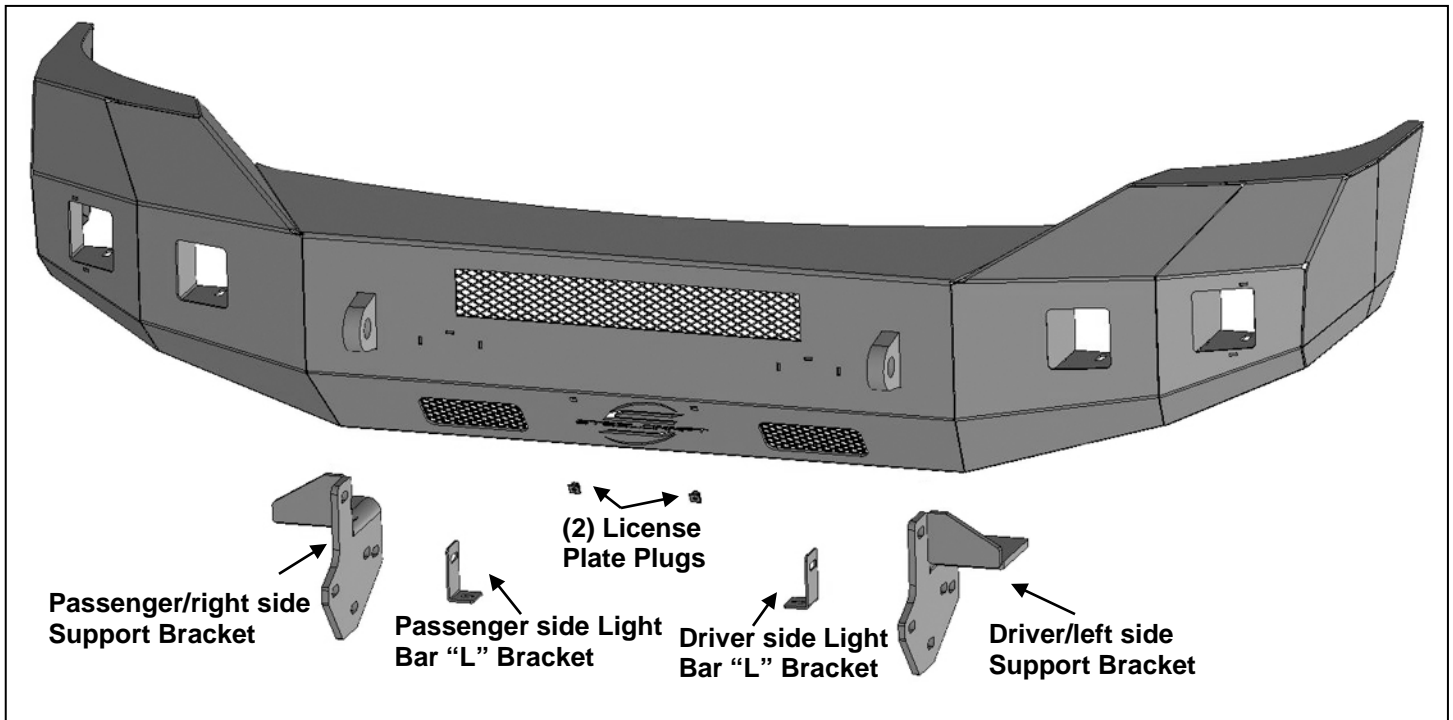

PROCEDURE:

REMOVE CONTENTS FROM BOX. VERIFY ALL PARTS ARE PRESENT. READ INSTRUCTIONS CAREFULLY BEFORE STARTING INSTALLATION. BUMPER IS HEAVY, ASSISTANCE IS HIGHLY RECOMMENDED TO AVOID POSSIBLE INJURY OR DAMAGE TO THE VEHICLE.

1. Remove the license plate and bracket. On models with factory fog lights, unplug both lights. Release the wiring harness from the clips attached to the back of the bumper, **(Figures 1 & 2)**. Move harness away from bumper.
2. Release the rubber air deflector from the back of the bumper. Next, remove the bumper supports attached to the bumper frame bracket and outer ends of the bumper, **(Figure 2)**.
3. Place blocks or jack stands under the front bumper to support it during mounting bolt removal. Once the bumper has been safely supported, remove the (4) factory bumper bolts, **(Figure 3)**. **WARNING!** Assistance is required to hold the bumper in place during bolt removal to prevent the bumper from falling. Carefully slide the bumper off over the tow hooks.
4. Remove the (4) factory hex nuts, lower frame extension and the (2) double bolt plates from the end of the frame, **(Figures 1, 4 & 5)**. Repeat this Step to remove the passenger side lower frame extension.
5. Select the Driver/left side Bracket, **(Figure 6)**. Attach the Driver/left side Bracket to the top of the frame using the provided (3) 12mm Hex Bolts, (6) 12mm Flat Washers, (3) 12mm Lock Washers and (3) 12mm Hex Nuts, **(Figure 6)**. Use (2) 12mm Hex Bolts, (4) 12mm Flat

FORTIS FRONT BUMPER
2011-16 FORD SUPERDUTY F250-350

Washers, (2) 12mm Lock Washers and (2) 12mm Hex Nuts to secure the Bracket to the side of the frame, **(Figure 7)**. **Alternative Option:** Insert (1) factory double bolt plate in through the frame channel and out through the side of the Bracket. Reuse the (2) factory hex nuts to secure the Bracket to the side of the frame, **(Figure 8)**. Do not tighten hardware at this time.

- 6. Optional Center LED light installation** (sold separately). **NOTE:** Light must be installed before Bumper Assembly is attached to ends of frame.
 - a.** Select the Driver side “L” Bracket. **NOTE:** “L” Brackets are offset for universal fitment for most LED bar style lights. Attach the Bracket to the top of the mounting tab on the back of the Bumper with the included (1) 8mm x 25mm Hex Bolt, (2) 8mm Flat Washers, (1) 8mm Lock Washer and (1) 8mm Hex Nut, **(Figure 9)**. Do not tighten hardware at this time.
 - b.** Repeat Previous Step for Passenger side “L” Bracket installation.
 - c.** Attach the LED Light Bar to the Brackets with (2) 8mm x 16mm Hex Bolts, (2) 8mm Lock Washers and (2) 8mm Flat Washers, **(Figure 9)**. Do not fully tighten hardware at this time.
 - d.** Center and adjust light position and tighten hardware.
 - e.** Follow light manufacturer’s instructions to wire the light to the vehicle’s electrical system once Bumper has been fully installed.
- 7.** With assistance, carefully position the Bumper Assembly up to the ends of the frame. Temporarily support the weight of the Bumper. **WARNING:** To avoid possible injury or damage to the vehicle, do not proceed until the bumper is fully and safely supported. Models with LED light, check for clearance before fully installing Bumper assembly.
- 8.** Attach the Bumper to the inside of the Brackets using (6) 12mm Hex Bolts, (12) 12mm Flat Washers, (6) 12mm Lock Washers and (6) 12mm Hex Nuts, **(Figures 10 & 11)**. Do not fully tighten hardware.
- 9. LED light installation at ends of bumper** (sold separately).
 - a.** Insert light into opening and up to mounting slot. Check for clearance between front and back of light, **(Figure 12)**.
 - b.** Follow the light manufacturer’s instructions to attach each light to slot in the top of the light opening.
 - c.** Repeat the above steps for passenger side light installation.
 - d.** Follow light manufacturer’s instructions to properly wire the light to the vehicle electrical system once Bumper has been fully installed.
- 10.** If front license plate is required, insert (2) Plastic Plugs into the square holes in the front of the Bumper. Reuse the factory screws to attach the license plate to the plastic plugs.
- 11.** Level and adjust the bumper and fully tighten all hardware.
- 12.** Do periodic inspections to the installation to make sure that all hardware is secure and tight.

To protect your investment, wax this product after installing. Regular waxing is recommended to add a protective layer over the finish. Do not use any type of polish or wax that may contain abrasives that could damage the finish. Mild soap may be used to clean the Front Bumper assembly.

Driver Side Installation Pictured

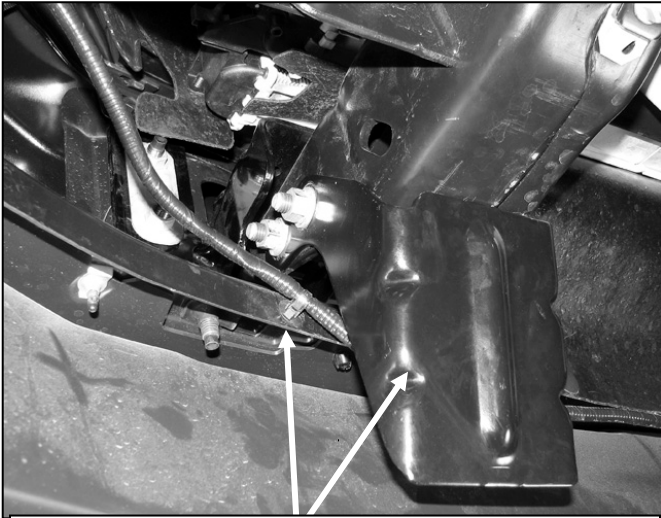

(Fig 1) Driver side lower frame extension and fog light wire harness pictured from behind bumper

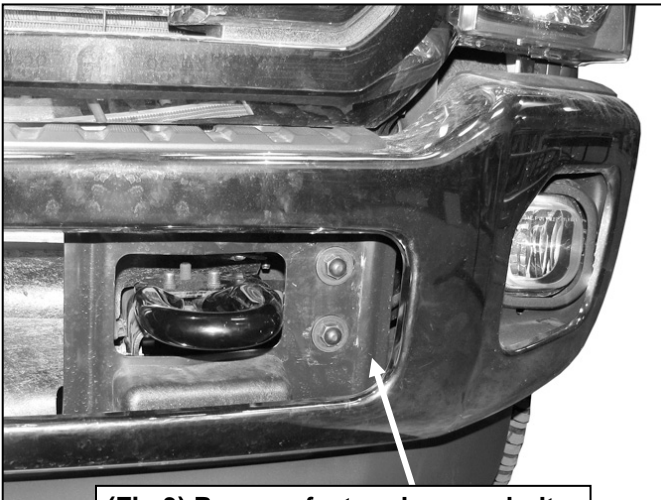

(Fig 3) Remove factory bumper bolts

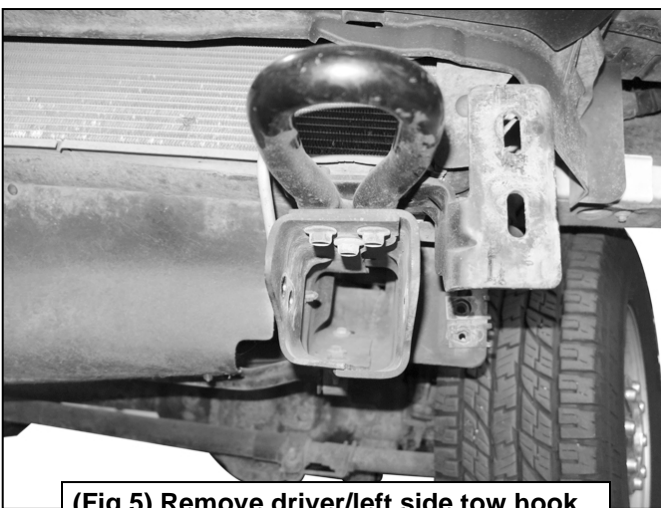

(Fig 5) Remove driver/left side tow hook

Remove hardware attaching bumper support brackets to frame

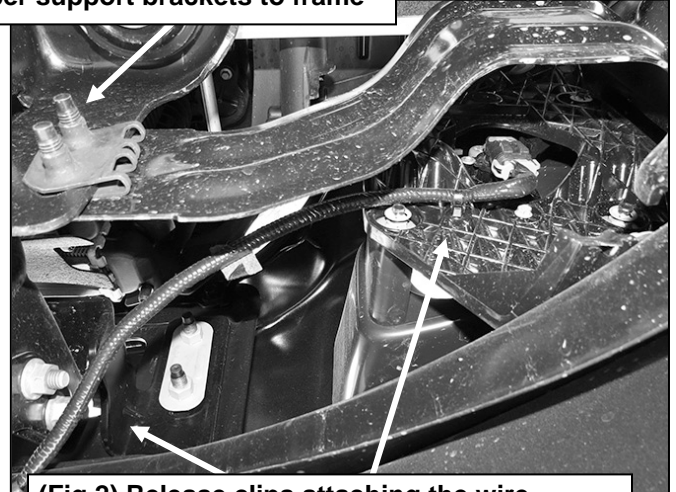

(Fig 2) Release clips attaching the wire harness for fog lights if equipped. Passenger side pictured from behind bumper

WARNING! Do not remove bumper bolts unless the bumper is properly supported on blocks or stands or the bumper may fall.

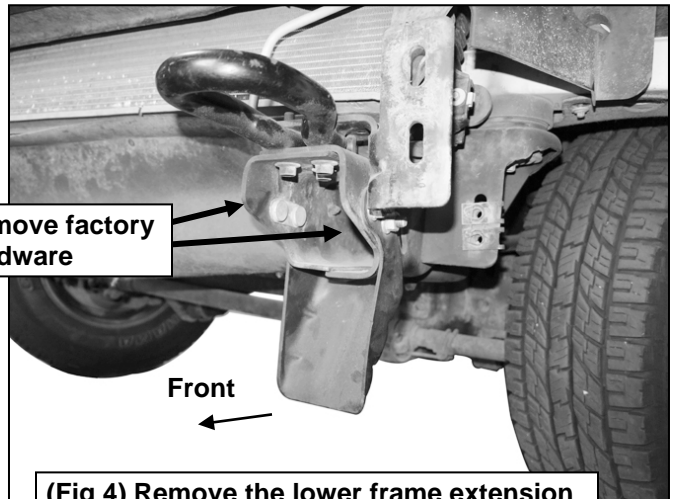

(Fig 4) Remove the lower frame extension

Driver Side Installation Pictured

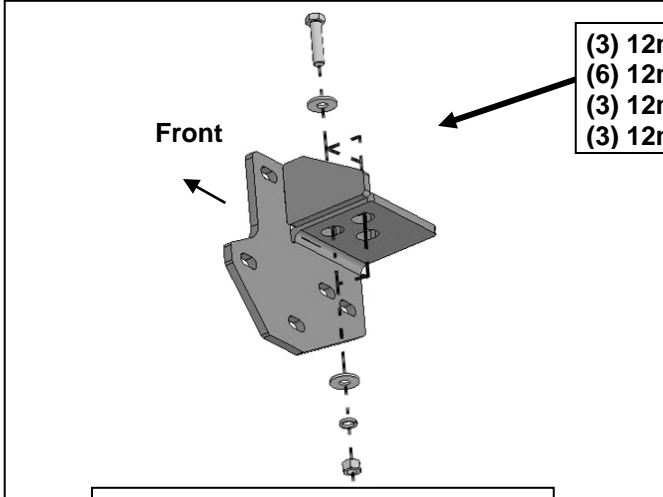

- (3) 12mm Hex Bolts
- (6) 12mm Flat Washers
- (3) 12mm Lock Washers
- (3) 12mm Hex Nuts

(Fig 6) Driver/left side Bracket attached to top of frame illustrated

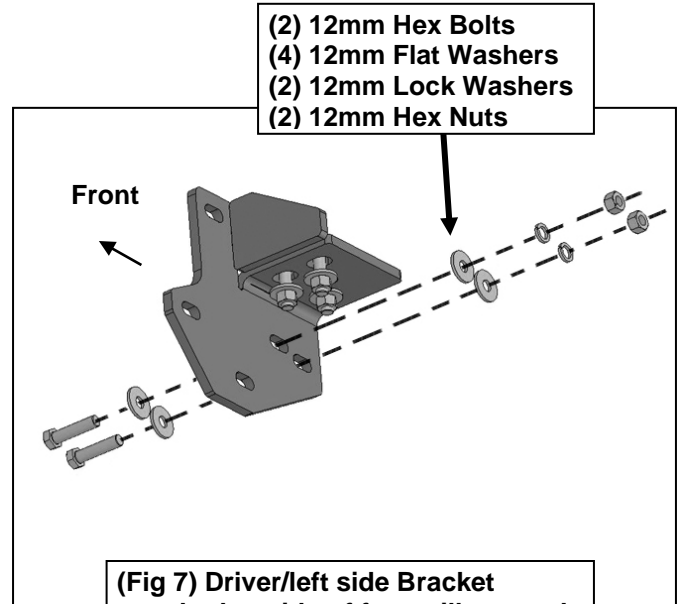

- (2) 12mm Hex Bolts
- (4) 12mm Flat Washers
- (2) 12mm Lock Washers
- (2) 12mm Hex Nuts

(Fig 7) Driver/left side Bracket attached to side of frame illustrated

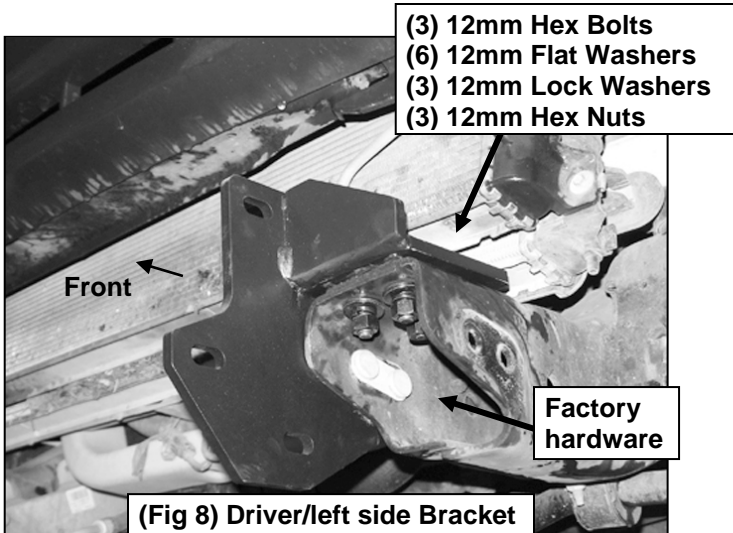

- (3) 12mm Hex Bolts
- (6) 12mm Flat Washers
- (3) 12mm Lock Washers
- (3) 12mm Hex Nuts

(Fig 8) Driver/left side Bracket attached to frame pictured

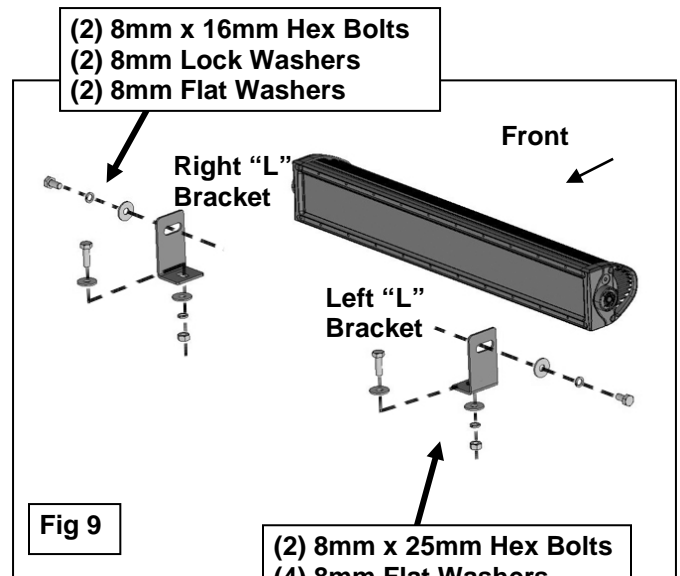

- (2) 8mm x 16mm Hex Bolts
- (2) 8mm Lock Washers
- (2) 8mm Flat Washers

- (2) 8mm x 25mm Hex Bolts
- (4) 8mm Flat Washers
- (2) 8mm Lock Washers
- (2) 8mm Hex Nuts

Fig 9

Driver Side Installation Pictured

WARNING! Do not crawl under bumper unless the bumper is properly supported on blocks or stands or the bumper may fall.

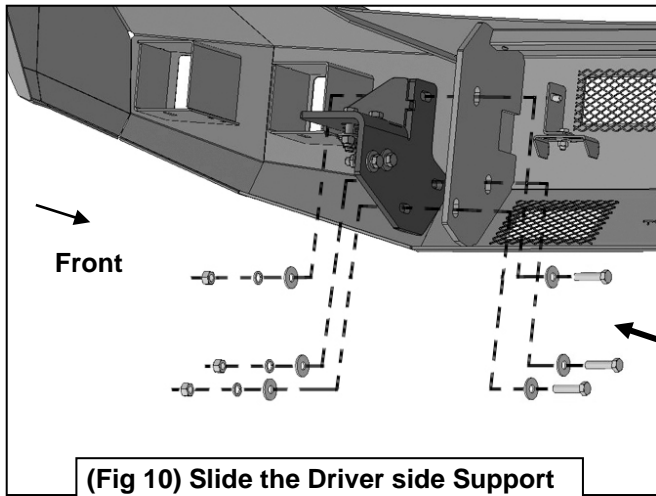

- (3) 12mm Hex Bolts
- (6) 12mm Flat Washers
- (3) 12mm Lock Washers
- (3) 12mm Hex Nuts

