

**PARTS LIST:**

1	Front Bumper Assembly	2	12-1.75mm x 55mm Hex Bolts
1	Driver/Left Frame Mounting Bracket	10	12-1.75mm x 45mm Hex Bolts
1	Passenger/Right Frame Mounting Bracket	24	12mm x 32mm x 3mm Flat Washers
1	Driver/Left Inner Support Bracket	14	12mm Lock Washers
1	Passenger/Right Inner Support Bracket	10	12-1.75mm Hex Nuts
1	Driver/Left LED Light Bracket	2	8-1.25mm x 25mm Hex Bolts
1	Passenger/Right LED Light Bracket	2	8-1.25mm x 16mm Hex Bolts
2	Plastic Plugs for license plate mount	6	8mm x 24mm x 2mm Flat Washers
2	12mm Double Nut Plates	4	8mm Lock Washers
2	12-1.75mm x 170mm Hex Bolts	2	8mm Hex Nuts

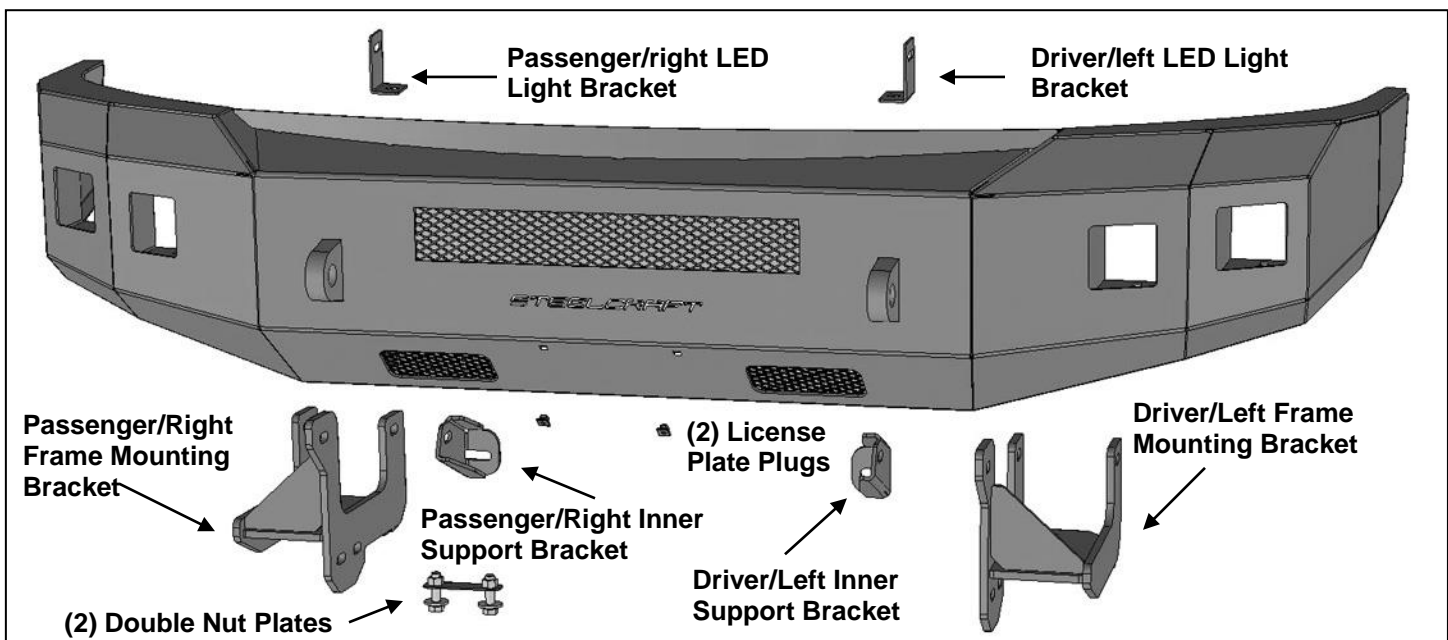

**PROCEDURE:**

**REMOVE CONTENTS FROM BOX. VERIFY ALL PARTS ARE PRESENT. READ INSTRUCTIONS CAREFULLY BEFORE STARTING INSTALLATION. BUMPER IS HEAVY, ASSISTANCE IS HIGHLY RECOMMENDED TO AVOID POSSIBLE INJURY OR DAMAGE TO THE VEHICLE.**

1. Remove the license plate and bracket. Open the hood and remove the hardware attaching the hood release lever to the steel bracket attached to the back of the bumper, **(Figure 1)**. Also remove the screws attaching the back of the plastic fascia to the hood release bracket. On models with factory fog lights, unplug the wiring harness leading to the bumper and move harness away from bumper.
2. Place blocks or jack stands under the front bumper to support it during mounting bolt removal. Once the bumper has been safely supported, remove the (2) large hex nuts from the back of each bumper bracket, **(Figure 2)**. **WARNING!** Assistance is required to hold the bumper in place during bolt removal to prevent the bumper from falling. Carefully slide the bumper off over the tow hooks. Next, remove the air dam from the bottom of the frame, **(Figure 3)**.
3. Remove the driver side tow hook, (if equipped), from the bottom of the frame. Leave the factory double nut plate inside the frame, **(Figure 4)**. On models without tow hook, insert (1) Double Nut Plate into the open end of the frame and line up the welded hex nuts with the holes in the bottom of the frame, **(Figure 4)**.
4. Next, select the driver side Frame Mounting Bracket, **(Figure 5)**. Attach the Bracket to the bottom of the frame and Double Nut Plate with (2) 12mm x 45mm Hex Bolts, (2) 12mm Lock Washers and (2) 12mm Flat Washers, **(Figures 5 & 6)**. Leave hardware loose at this time.
5. Insert (1) 12mm x 170mm Long Hex Bolt with (1) 12mm Flat Washer through the outside of the mounting tab on the Frame Bracket, through the frame and inner tab, **(Figures 5 & 6)**. Secure with (1)

12mm Flat Washer, (1) 12mm Lock washer and (1) 12mm Hex Nut, (**Figures 5 & 6**). Do not fully tighten hardware.

6. Repeat **Steps 3—5** to install the passenger/right side Frame Bracket.
7. Remove the steel bracket attached to the back of the original bumper for the hood release, (**Figure 7**). Reuse the factory hardware to attach the bracket to the mounting tabs on the back of the plastic fascia. Reattach the hood release lever to the steel bracket, (**Figure 8**). Tighten hardware at this time.
8. **Optional Center LED light installation (sold separately). NOTE:** It may be easier to install the light before Bumper Assembly is attached to the Frame Brackets.
  - a. Select the L/R “L” Brackets, (**Figure 9**). **NOTE:** “L” Brackets are offset for universal fitment for most LED bar style lights. Attach the LED light assembly to the “L” Brackets with the included (2) 8mm x 16mm Hex Bolts, (2) 8mm Lock Washers and (2) 8mm Flat Washers. Do not fully tighten hardware at this time. **NOTE:** “L” Brackets may require modification for hardware larger than 8mm or use brackets supplied with light if possible.
  - b. Attach the light and Brackets to the top of the (2) tabs on the back of the Bumper with the included 8mm x 25mm Hex Bolts, (4) 8mm Flat Washers, (2) 8mm Lock Washers and (2) 8mm Hex Nuts, (**Figure 9**). Adjust light position and tighten hardware.
  - c. Follow light manufacturer’s instructions to wire the light once Bumper has been fully installed.
9. With assistance, position the Bumper Assembly up to the outside of the Frame Brackets. Temporarily support the weight of the Bumper. **WARNING:** To avoid possible injury or damage to the vehicle, do not proceed until the bumper is fully and safely supported.
10. Line up the (2) lower mounting holes in the driver/left side Frame Bracket with the holes in the inner mounting plate on the back of the Bumper. Attach the Bumper to the Bracket with the included (2) 12mm x 45mm Hex Bolts, (4) 12mm Flat Washers, (2) 12mm Lock Washers and (2) 12mm Hex Nuts, (**Figures 10 & 11**). Snug but do not tighten hardware at this time. Repeat this **Step** to attach the passenger side of the Bumper to the Frame Bracket.
11. Select the driver/left Inner Support Bracket, (**Figure 12**). Line up slot in the flat end of the Support Bracket with the top slot in the bumper mounting flange and the Mounting Bracket. Attach the Support Bracket to the mounting flange with the longer (1) 12mm x 55mm Hex Bolt, (2) 12mm Flat Washers, (1) 12mm Lock Washer and (1) 12mm Hex Nut, (**Figures 12 & 14**). Line up the bent end of the Support Bracket with the inner hole in the mounting flange on the frame. Attach the Support Bracket to the mounting flange with (1) 12mm x 45mm Hex Bolt, (2) 12mm Flat Washers, (1) 12mm Lock Washer and (1) 12mm Hex Nut, (**Figures 13 & 14**). Do not fully tighten hardware at this time. Repeat this Step to install the passenger/right Support Bracket.
12. Level and adjust the Bumper and fully tighten all hardware to 65-70ft-lbs.
13. Use the included (2) push-in plastic nuts to attach the front license plate, (if required), to the (2) holes in the front bumper, (**Figure 15**).
14. Do periodic inspections to the installation to make sure that all hardware is secure and tight.

**To protect your investment**, wax this product after installing. Regular waxing is recommended to add a protective layer over the finish. Do not use any type of polish or wax that may contain abrasives that could damage the finish. Mild soap may be used to clean the Front Bumper assembly.

Driver Side Installation Pictured

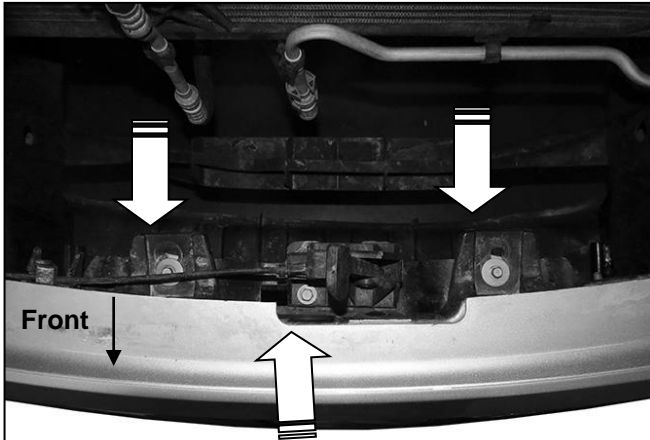

(Fig 1) Remove screws attaching hood latch to bracket and bracket to bumper (arrows)

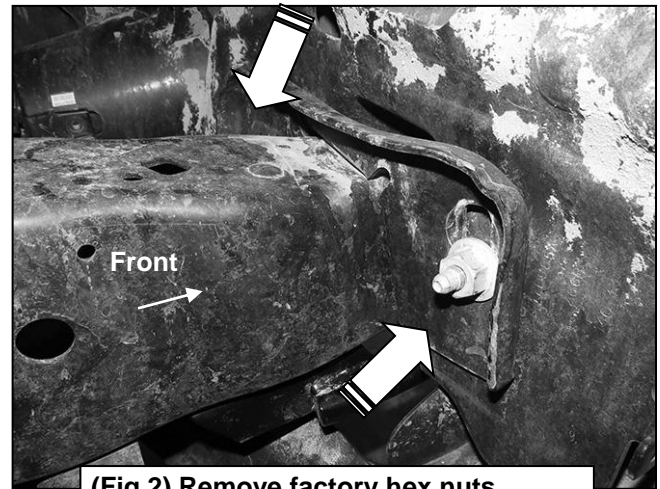

(Fig 2) Remove factory hex nuts (arrows) from back of bumper bracket

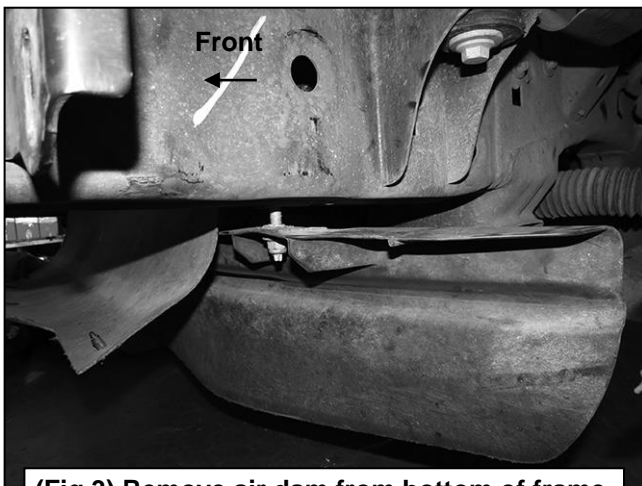

(Fig 3) Remove air dam from bottom of frame

**WARNING!** Do not remove bumper bolts unless the bumper is properly supported on blocks or stands or the bumper may fall.

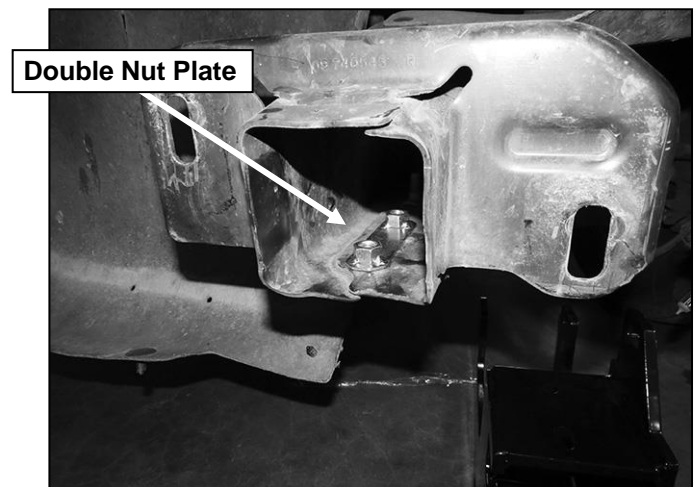

(Fig 4) Models without tow hook, slide Double Nut Plate into open end of frame. Models with tow hook, remove tow hook from bottom of frame and leave factory nut plate in place in frame

### Driver Side Installation Pictured

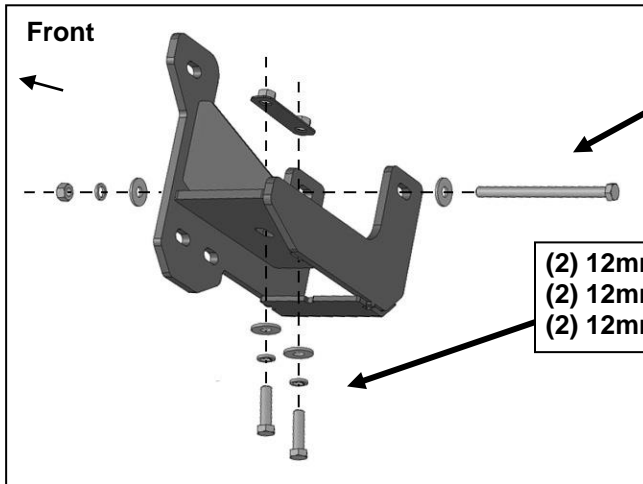

12mm x 170mm Long Hex Bolt  
(2) 12mm Flat Washers  
12mm Lock Washer  
12mm Hex Nut

(2) 12mm x 45mm Hex Bolts  
(2) 12mm Lock Washers  
(2) 12mm Flat Washers

12mm x 170mm Long Hex Bolt  
(2) 12mm Flat Washers  
12mm Lock Washer  
12mm Hex Nut

(Fig 5) Attach Driver/left Frame Bracket to Double Nut Plate in frame, (Fig 6)

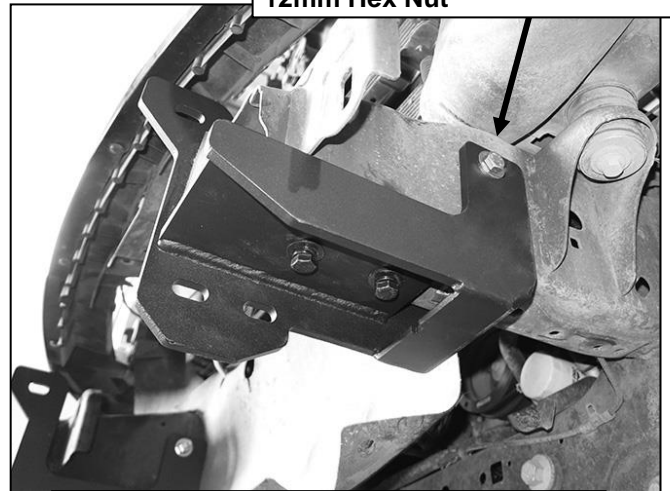

(Fig 6) Driver/left Frame Bracket installed

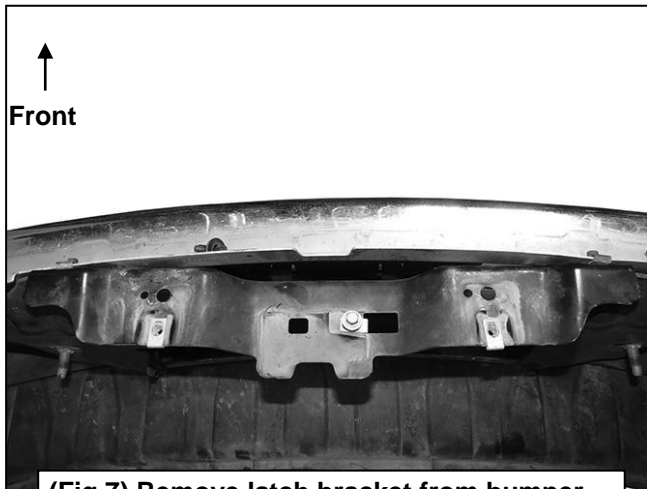

(Fig 7) Remove latch bracket from bumper

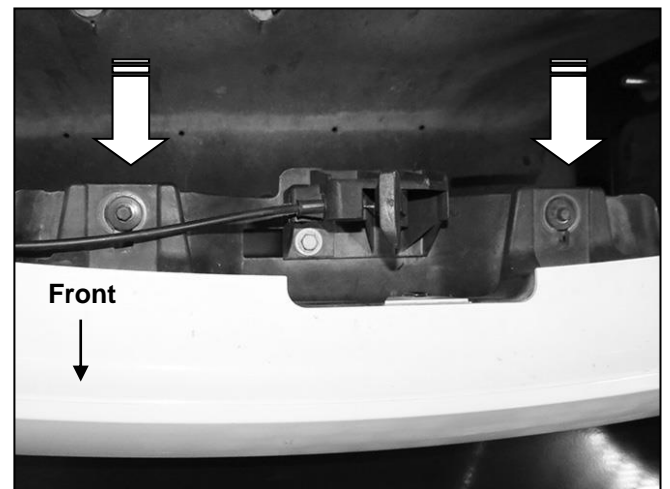

(Fig 8) Attach latch bracket to tabs on plastic fascia

**Driver Side Installation Pictured**

8mm x 16mm Hex Bolt  
8mm Lock Washer  
8mm Flat Washer

8mm x 25mm Hex Bolt  
(2) 8mm Flat Washers  
8mm Lock Washer  
8mm Hex Nut

**WARNING!** Do not crawl under bumper unless the bumper is properly supported on blocks or stands or the bumper may fall.

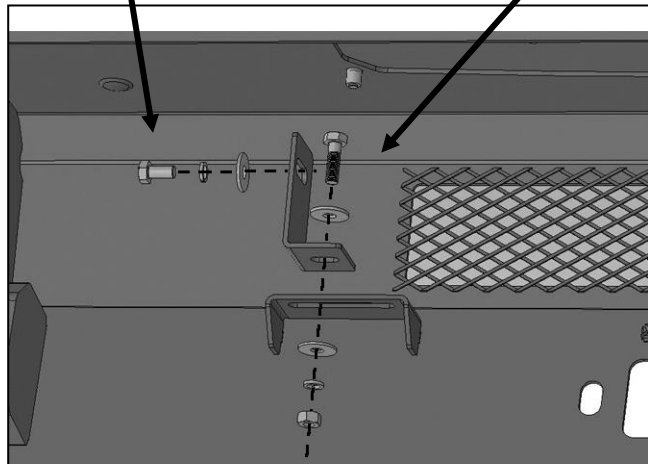

(Fig 9) Universal LED Brackets (light not included)

(2) 12mm x 45mm Hex Bolts  
(4) 12mm Flat Washers  
(2) 12mm Lock Washers  
(2) 12mm Hex Nuts

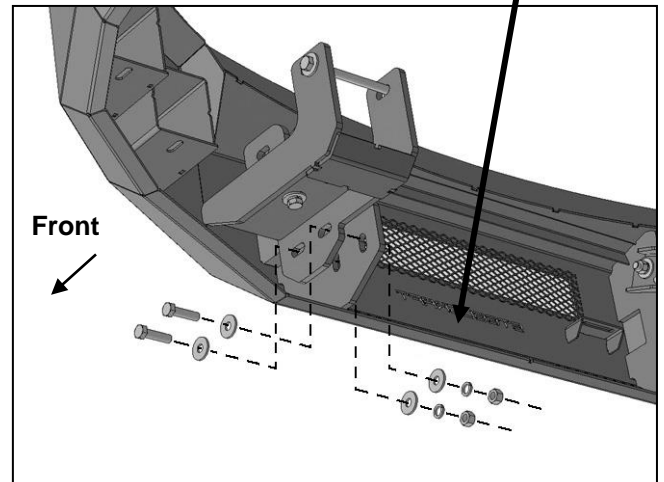

(Fig 10) Attach Bumper to inside of Frame Bracket

(2) 12mm x 45mm Hex Bolts  
(4) 12mm Flat Washers  
(2) 12mm Lock Washers  
(2) 12mm Hex Nuts

12mm x 55mm Hex Bolt  
(2) 12mm Flat Washers  
12mm Lock Washer  
12mm Hex Nut

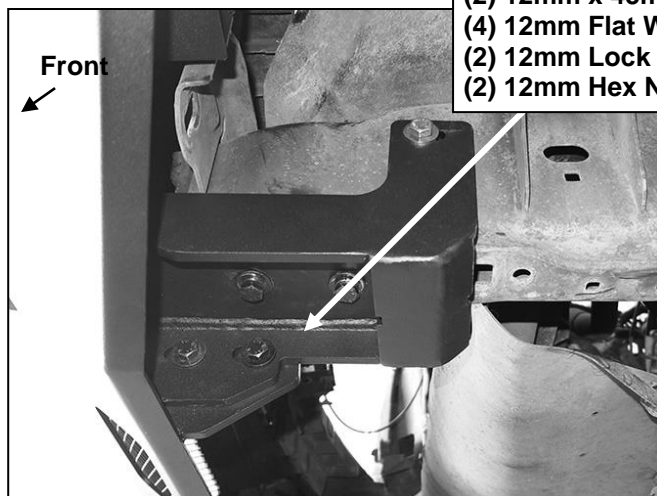

(Fig 11) Attach Bumper to inside of Frame Bracket

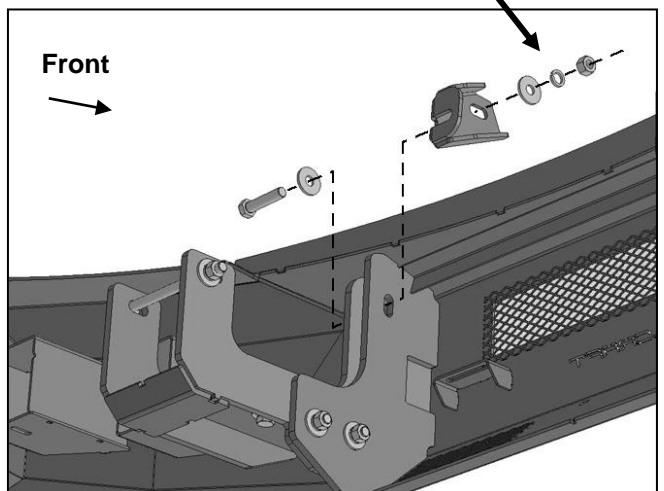

(Fig 12) Attach Driver side Inner Support Bracket to bumper flange on frame and Frame Bracket

### Driver Side Installation Pictured

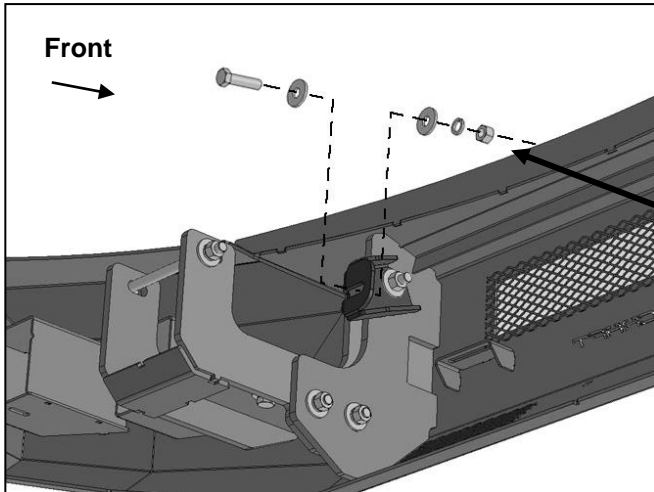

12mm x 45mm Hex Bolt  
(2) 12mm Flat Washers  
12mm Lock Washer  
12mm Hex Nut

12mm x 55mm Hex Bolt  
(2) 12mm Flat Washers  
12mm Lock Washer  
12mm Hex Nut

(Fig 13) Attach Driver side Inner Support Bracket to bumper flange on frame and Frame Bracket

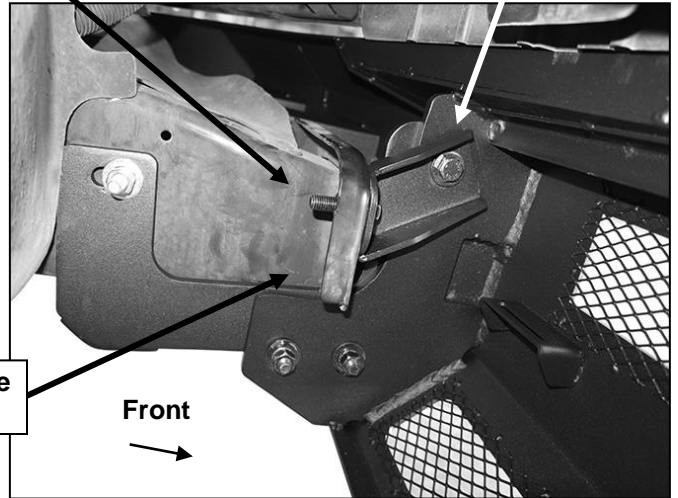

(Fig 14) Driver/left side Inner Support Bracket installation pictured from behind Bumper

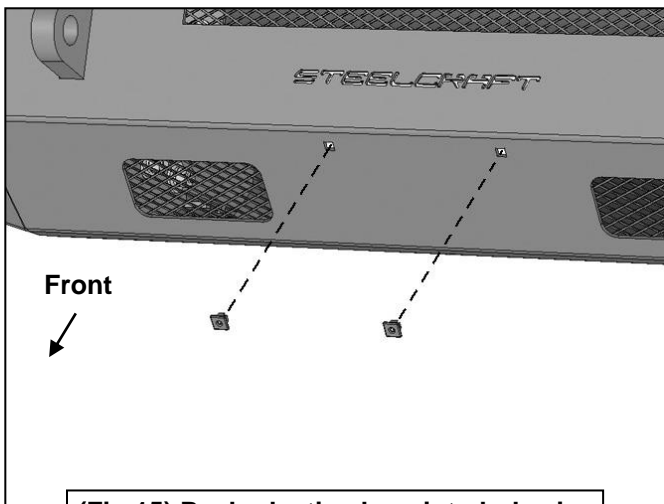

(Fig 15) Push plastic plugs into holes in Bumper for license plate if required.



Complete Installation