



# **INSTALLATION INSTRUCTIONS**

## **ELEVATION REAR BUMPER**

**1999-16 FORD SUPERDUTY F250-350**

**#PW016687**

## PARTS LIST:

1	Elevation Rear Bumper Assembly	2	Plastic Plugs for license plate mount
2	2-hole Spacer Plates (for tow hitch only)	8	4mm x 10mm Socket Head Screws
4	Sensor Plugs	1	Wrench

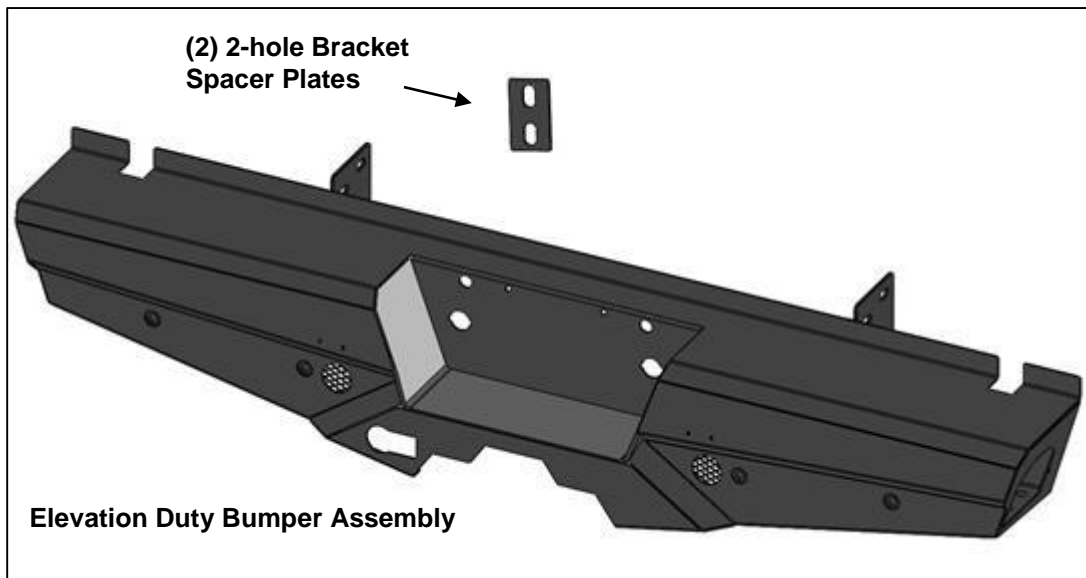

## PROCEDURE:

**REMOVE CONTENTS FROM BOX. VERIFY ALL PARTS ARE PRESENT. READ INSTRUCTIONS CAREFULLY BEFORE STARTING INSTALLATION. BUMPER IS HEAVY, ASSISTANCE IS HIGHLY RECOMMENDED TO AVOID POSSIBLE INJURY OR DAMAGE TO THE VEHICLE.**

1. Remove the license plate and bracket. On models with back up sensors, unplug the sensors and move the wiring harness away from the factory bumper. Next, remove the sensors.
2. Unplug the factory license plate lights. Remove the license plate lights and move the harness away from the bumper. Also temporarily move the trailer/towing wiring harness from the bottom of the hitch and move it away from the hitch, **(Figure 1)**. Next, remove the hitch from the bottom of the frame, **(Figure 2)**. **WARNING:** Assistance is highly recommended.
3. Place blocks or jack stands under the bumper to support it during mounting bolt removal. Once the bumper has been safely supported, remove the factory bumper bolts, double bolt plates and slide the rear bumper off of the frame, **(Figure 3)**. **WARNING!** Assistance is required to hold the bumper in place during hardware removal to prevent the bumper from falling.
4. With assistance, position the HD Bumper Assembly up to the side and end of the frame. Temporarily support the weight of the Bumper Assembly. **WARNING:** To avoid possible injury or damage to the vehicle, do not proceed until the Bumper is fully and safely supported.
5. Line up the (2) holes in the passenger side vertical mounting plate with the (2) holes in the side of the frame. Reuse the factory double bolt plate and hardware to attach the plate to the frame, **(Figure 4)**. Do not fully tighten hardware at this time. Repeat to attach the driver side mounting plate to the frame.
6. With assistance, line up the hitch with the rear mounting holes toward the end of the frame and bottom mounting plate on the bumper. Use the (4) factory hex bolts to attach the hitch to the bottom mounting plates, **(Figures 5 & 10)**. Leave hardware loose at this time.
7. Insert (1) 2-hole Spacer Plate between the bottom of the passenger side of the frame and the (2) forward holes in the factory tow hitch, **(Figures 6, 10, 11)**. Use the factory hardware to attach the front of the hitch to the Spacer and the bottom of the frame, **(Figures 7 & 10)**. Repeat to attach the driver side front mount on the tow hitch, **(Figures 8 & 10)**. Do not fully tighten hardware at this time.
8. Level and adjust the bumper and fully tighten all hardware to 65-70ft-lbs.
9. Reattach the wire harness to the bottom of the tow hitch.

10. Select the (2) factory license plate lights. Push the lights into the holes in the Bumper **(Figure 9)**. Reattach all wiring harnesses.
11. Use the included (2) push-in plastic nuts to attach the license plate to the (2) holes in the Bumper Assembly, **(Figure 9)**.
12. Do periodic inspections to the installation to make sure that all hardware is secure and tight.
13. **Models with bumper mounted sensors:**
  - a. Insert the sensor into the socket in the back of the Bumper Assembly. Use the included (2) 4mm Socket Head Screw to attach the sensor to the socket, **(Figure 12)**. Repeat for all sensors.
  - b. Reinstall the factory wiring harness to all sensors.
14. **Models without bumper mounted sensors:**
  - a. Insert (4) sensor plugs in the back of the Bumper Assembly.

**To protect your investment**, wax this product after installing. Regular waxing is recommended to add a protective layer over the finish. Do not use any type of polish or wax that may contain abrasives that could damage the finish. Mild soap may be used to clean the Elevation Rear Bumper assembly.



**(Fig 1)** Remove trailer harness from bottom of hitch or back of bumper

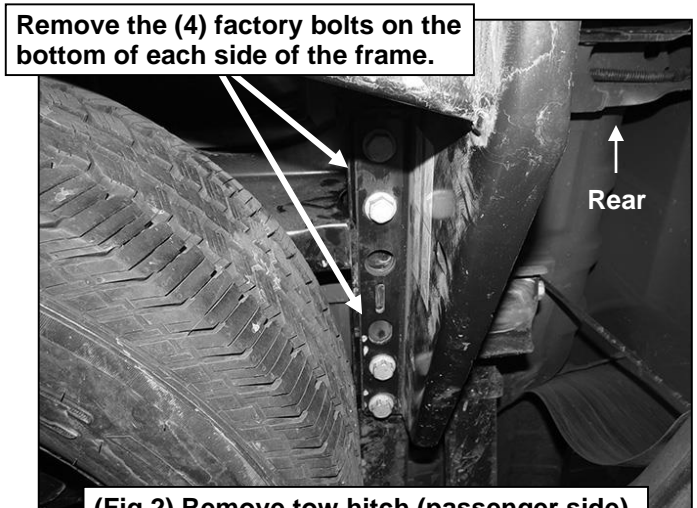

**(Fig 2)** Remove tow hitch (passenger side)

**WARNING!** Do not remove bumper bolts unless the bumper is properly supported on blocks or stands or the bumper may fall.

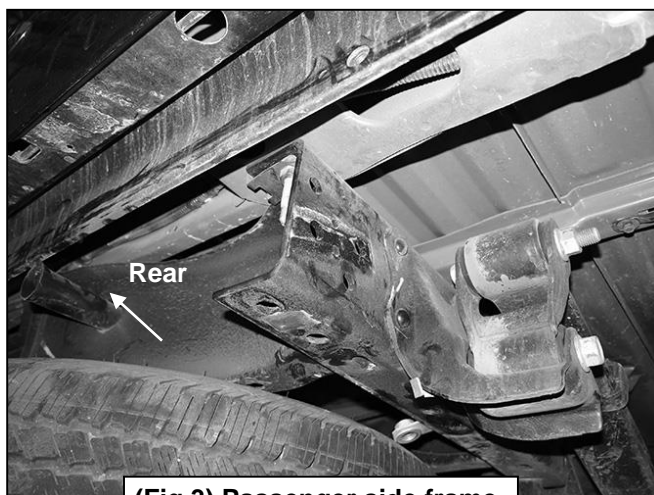

**(Fig 3)** Passenger side frame

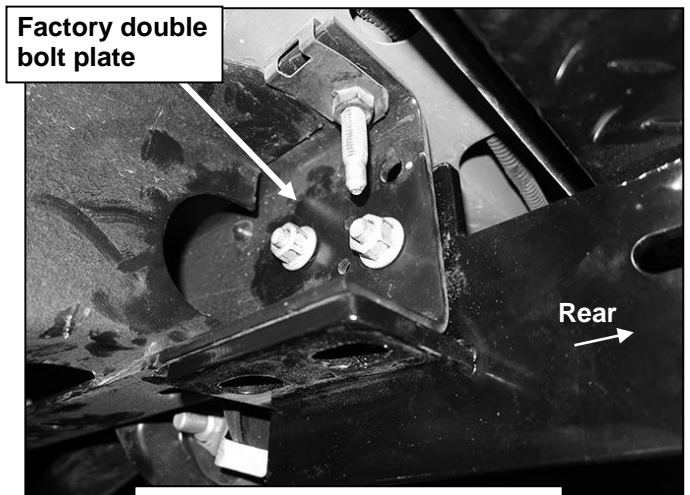

**(Fig 4)** Passenger side pictured

Factory double  
bolt plate

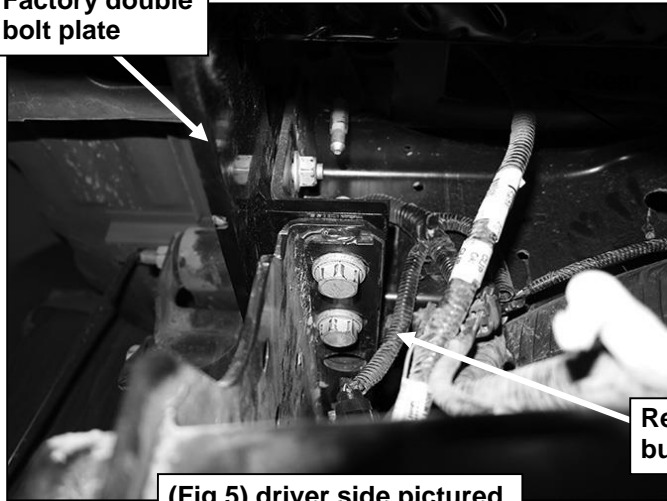

(Fig 5) driver side pictured

**WARNING!** Do not crawl under bumper unless the bumper is properly supported on blocks or stands or the bumper may fall.



(Fig 6) Spacer required for models with receiver hitch



(Fig 7) Passenger side installation

Insert 2-hole Spacer Plate between front mounting tab on hitch and bottom of frame (arrow)

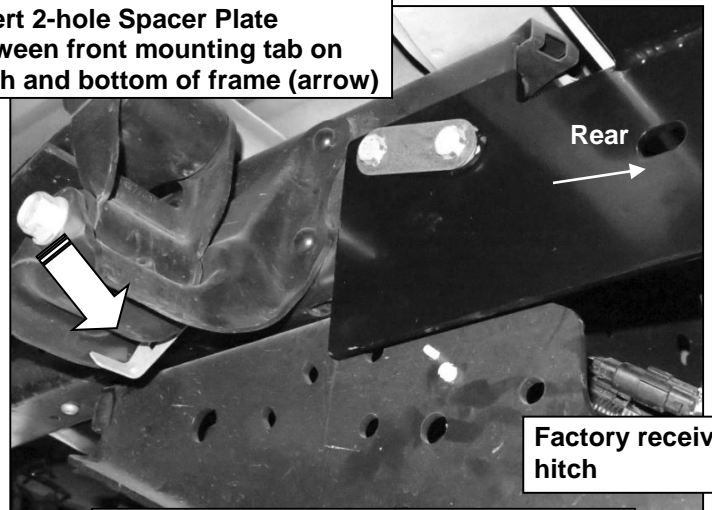

Factory receiver hitch

(Fig 8) Driver side installation with hitch

(2) Plastic Plugs

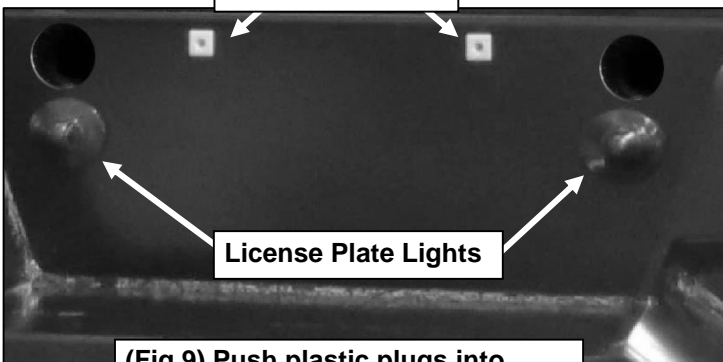

(Fig 9) Push plastic plugs into holes in Bumper for license plate

**WARNING!** Do not crawl under bumper unless the bumper is properly supported on blocks or stands or the bumper may fall.

(2) 2-hole frame Spacers  
(required to space factory  
receiver hitch only)

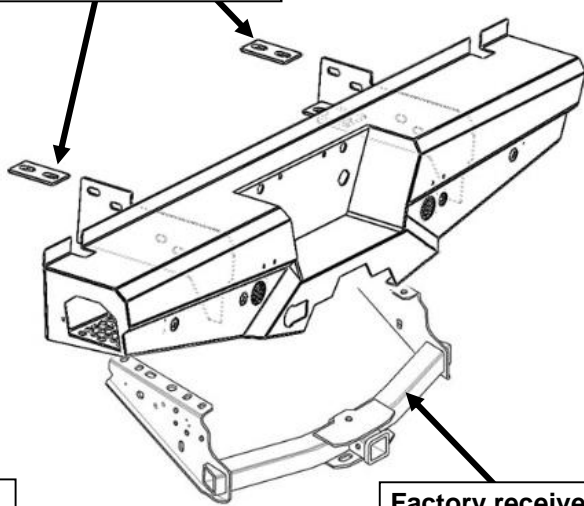
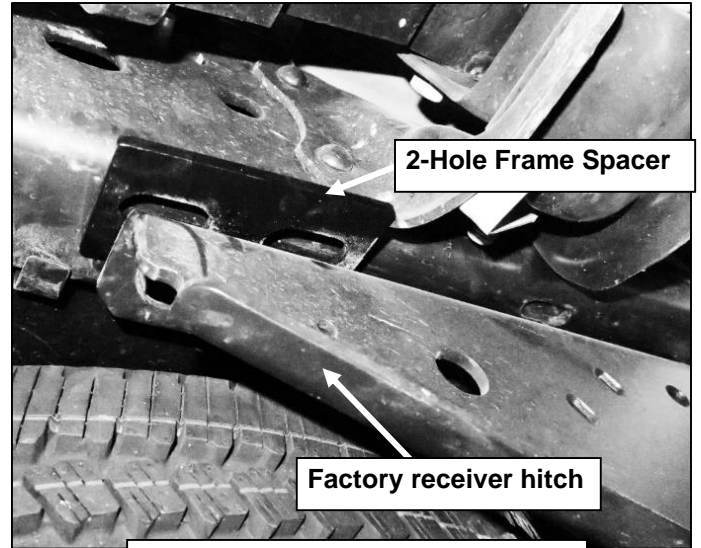
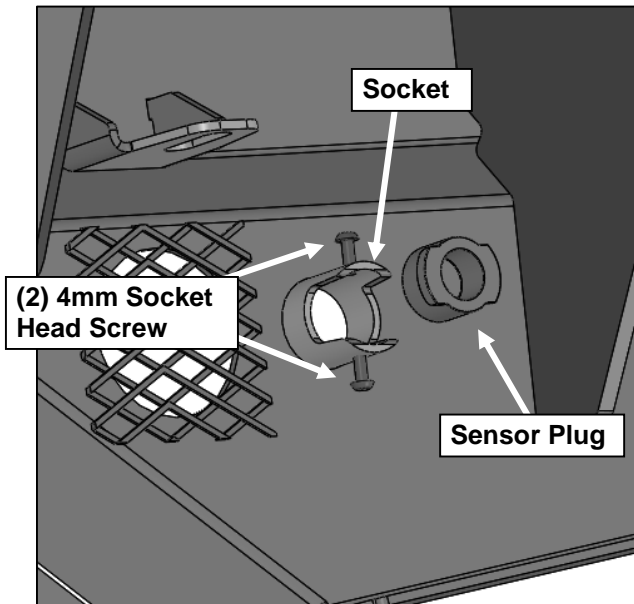

Fig 10

Factory receiver hitch



(Fig 11) Driver side space location



(Fig 12) Insert sensor (if equipped) into socket on  
back of bumper and hold in place with (2) 4mm  
Screws. If not equipped with sensors insert (1)  
sensor plugs into each socket.

**IMPORTANT:** Sensors fit snug in sockets.  
The 4mm Screws are only used to apply  
slight pressure to lock the sensors in  
place. Tighten both screws evenly until  
they touch the sensor body only. Do not  
overtighten screws or damage to sensors  
will result.



Complete Installation