

**ELEVATION FRONT BUMPER
2010-18 DODGE RAM 2500-3500**

PARTS LIST:

1	Elevation Front Bumper Assembly	2	License Plate Mounting Plugs
2	Frame Mounting Brackets	6	Sensor Plugs
8	12-1.75mm x 50mm Hex Bolts	1	Wrench
4	12mm x 90mm Hex Bolts	6	15.5mm x 25mm x 2mm Foam Washers
12	4mm x 10mm Socket Head Screws	6	Retaining Rings
24	12mm x 37mm OD x 3mm Flat Washers	4	Wiring Harnesses
12	12mm Nylon Lock Nuts	1	Sensor Covers Kit

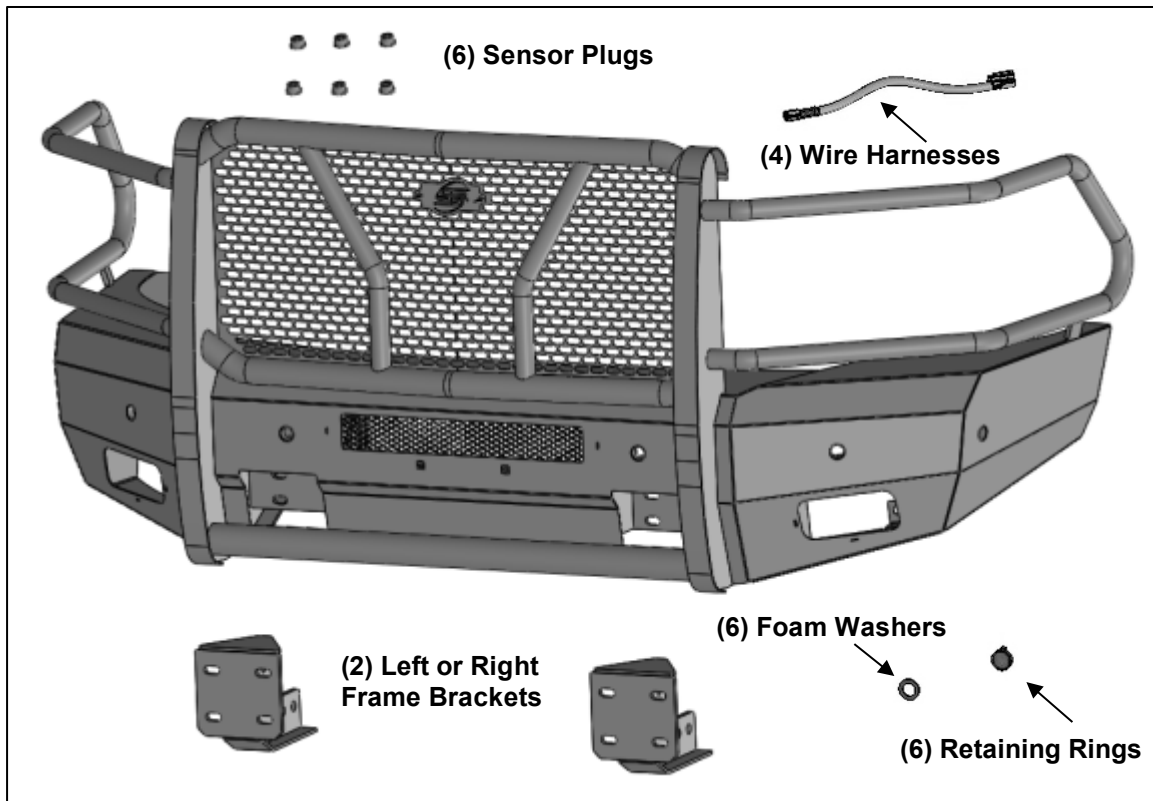

PROCEDURE:

- 1. REMOVE CONTENTS FROM BOX. VERIFY ALL PARTS ARE PRESENT. READ INSTRUCTIONS CAREFULLY BEFORE STARTING INSTALLATION. BUMPER IS HEAVY, ASSISTANCE IS HIGHLY RECOMMENDED. CUTTING MAY BE REQUIRED.**
- Remove the license plate. On models with bumper mounted sensors, unplug all sensors. Release the wiring harnesses from the clips attached to the back of the bumper. On models with factory fog lights, unplug both lights and release the wiring harness from the back of the bumper, **(Figure 1)**. Move all wiring harnesses away from bumper.
- Open the front hood and temporarily remove the top plastic cover between the radiator and the grille. Next, remove the plastic radiator grille for easier access to top bumper bracket bolts, **(Figure 2)**. **NOTE:** Pay close attention to the type and location of all factory hardware for reinstallation. Move the grille and cover to a clean, stable work area.
- Release the clips attaching the lower splash guard to the back of the front bumper, (if equipped). Locate the factory bumper bolts attaching the outer bumper to the inner brackets, **(Figure 3 & 4)**. With assistance, remove the bumper assembly, **(Figure 5)**. **WARNING!** Assistance is required to hold the bumper in place during hardware removal to prevent the bumper from falling. Slide the bumper assembly off of the tow hooks.

**ELEVATION FRONT BUMPER
2010-18 DODGE RAM 2500-3500**

5. Next, remove the (2) tow hooks. Remove the inner bumper brackets and lower frame extensions from the ends of the frame, **(Figures 5—7)**. **NOTE:** Lower frame extensions cannot be reinstalled.
IMPORTANT: On some models equipped with turbo diesel, the intercooler and lower mounting bracket will need to be loosened or removed to remove the double bolt plate attaching the bumper bracket to the end of the frame. Assistance is recommended. **OPTION:** To remove the double bolt plates without removing the intercooler, use a hacksaw to cut the threaded ends off of the double bolt plates. Reinstall the intercooler and brackets, (if removed), once bolt plates and bumper brackets have been removed, **(Figures 6 & 7)**.
6. Select (1) Frame Bracket. Line up the holes in the Bracket with the outside of the frame. Reuse the factory double bolt plate to attach the Bracket to the outside of the frame. If the double bolt plate was cut use the provided (2) 12mm x 90mm Hex Bolts, (4) 12mm Flat Washers and (2) 12mm Nylon Lock Nuts. Reuse the factory bumper bracket hardware to attach the Bracket to the outside of the frame, **(Figure 8)**. **NOTE:** Insert bolts through Frame Bracket and out through the frame. Snug but do not fully tighten hardware at this time. Repeat this Step to install the Frame Bracket on the passenger side.
7. Carefully remove all sensors from the back of the OE bumper, if equipped. Sensors must be installed in Bumper, (if equipped), before installing Bumper Assembly.

Models without bumper sensors:

- a. Select the included (6) Rubber Plugs.
- b. From behind bumper, push plugs into sensor mounting holes.

Models with bumper mounted sensors:

- a. Remove factory washer from sensor. Attach Foam Washer onto the front of the sensor.
 - b. Push the sensor in from the back of the Bumper until it is flush with the sensor sleeve. **NOTE:** Sensor tabs may need to be trimmed to fit sensor inside the sensor sleeve. Push (1) Retaining Ring into sensor sleeve to secure the sensor in place, **(Figure 9)**.
 - c. Repeat the previous steps for the remaining sensors.
 - d. Starting on the driver/left side of the bumper, connect the OE sensor wire harness to the first two driver/left side sensors.
 - e. Use the provided wire harness extensions to connect the remaining four center and passenger/right side sensors to the OE sensor wire harness.
8. With assistance, line up the Elevation Bumper assembly with the (2) Frame Mounting Brackets. Attach the Bumper to the (2) Brackets with (8) 12mm Hex Bolts, (16) 12mm Flat Washers and (8) 12mm Nylon Lock Nuts, **(Figure 10)**. **NOTE:** Stands or blocks are highly recommended to support weight of bumper during installation. Snug but do not fully tighten hardware at this time.
 9. With assistance, align and adjust the Elevation Bumper to the vehicle and tighten all hardware.
 10. Carefully remove both fog lights from the back of the OE bumper, if equipped.

Models with fog lights:

- a. On models with factory fog lights, carefully snap each fog light into the (3) mounting tabs on the back of the Bumper, **(Figure 11)**.
 - b. Reattach the factory wiring harness to fog lights.
11. Select (1) factory tow hook. Reuse the factory hardware to attach the tow hook to the mounting plate behind the front of the bumper, **(Figure 12)**. Repeat to install the remaining tow hook.
 12. Remove license plate, (if required), from factory bumper. Install (2) Plastic License Plate Plugs into the holes in the Elevation Bumper. Reuse factory screws to attach license plate to Plugs.
 13. Use a sharp knife or hacksaw blade to cut off lower portion of fender liner to match Bumper profile as desired.
 14. Do periodic inspections to the installation to make sure that all hardware is secure and tight.

To protect your investment, wax this product after installing. Regular waxing is recommended to add a protective layer over the finish. Do not use any type of polish or wax that may contain abrasives that could damage the finish. Mild soap may be used to clean the Bumper Assembly.

Driver Side Installation Pictured

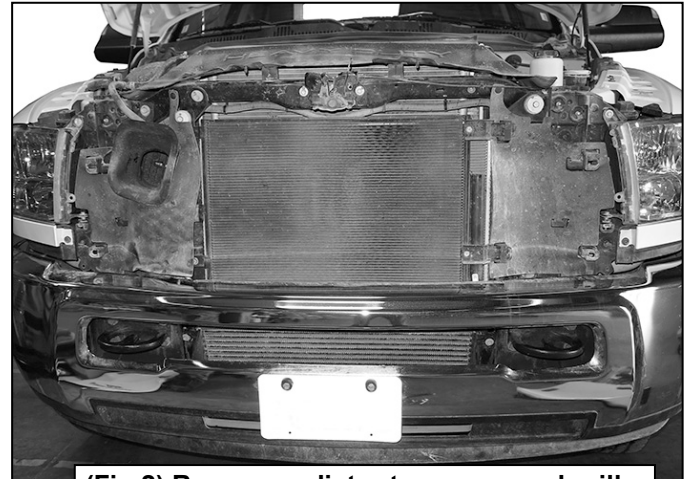
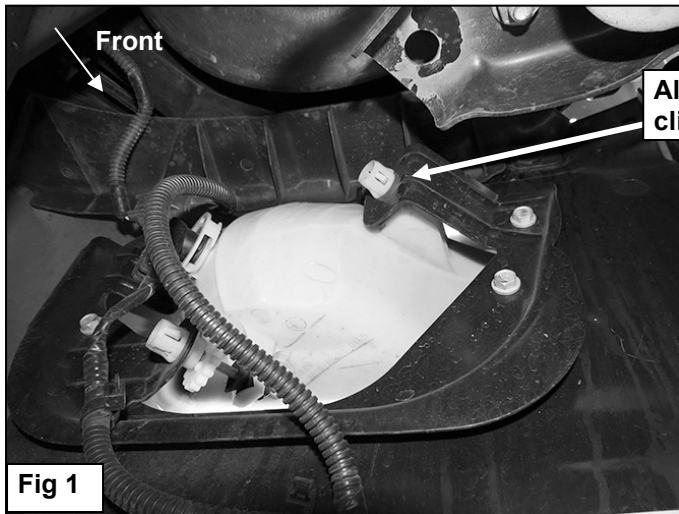

(Fig 2) Remove radiator top cover and grille



Remove lower frame extension
(pictured from below)

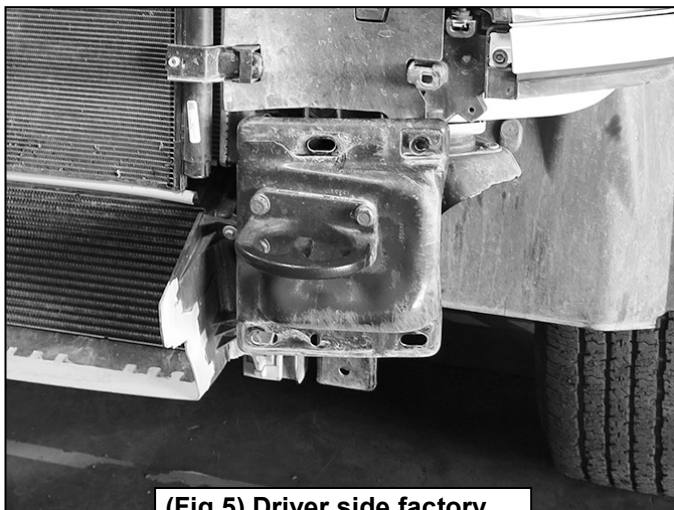
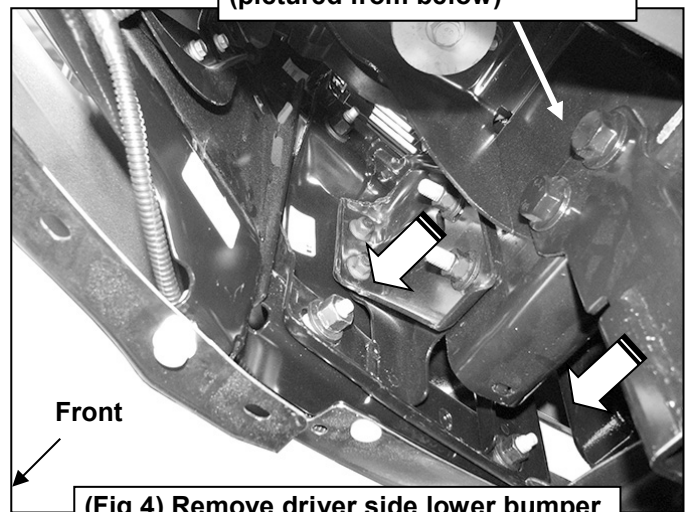

(Fig 5) Driver side factory bumper bracket and tow

Driver Side Installation Pictured

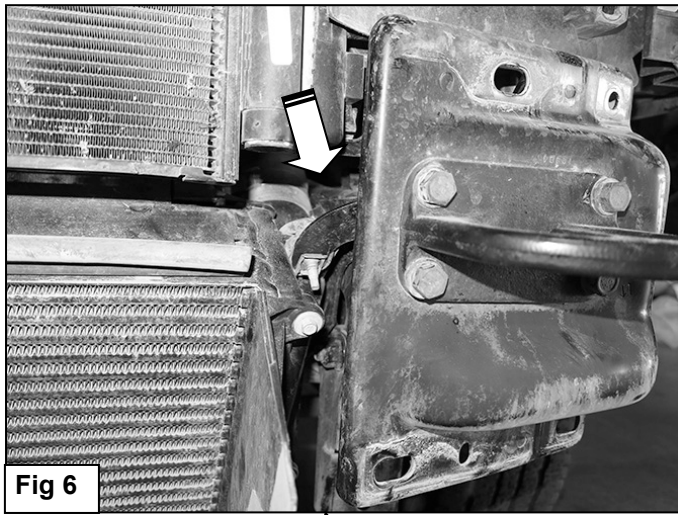

Diesel models, loosen top support bracket hardware at frame and intercooler (large arrow). Temporarily remove lower hanging intercooler bracket from side of frame

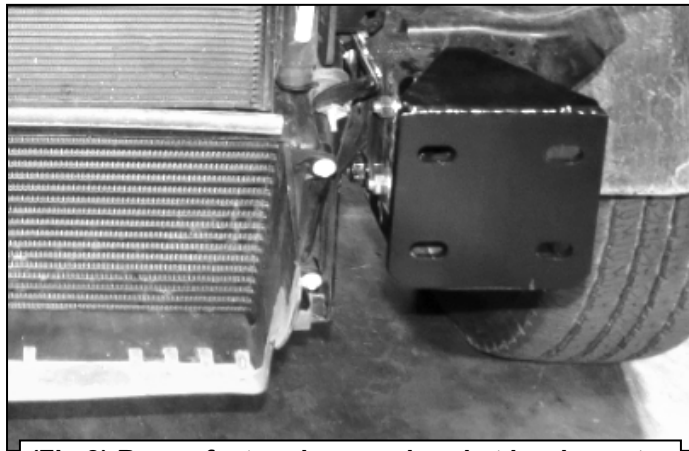
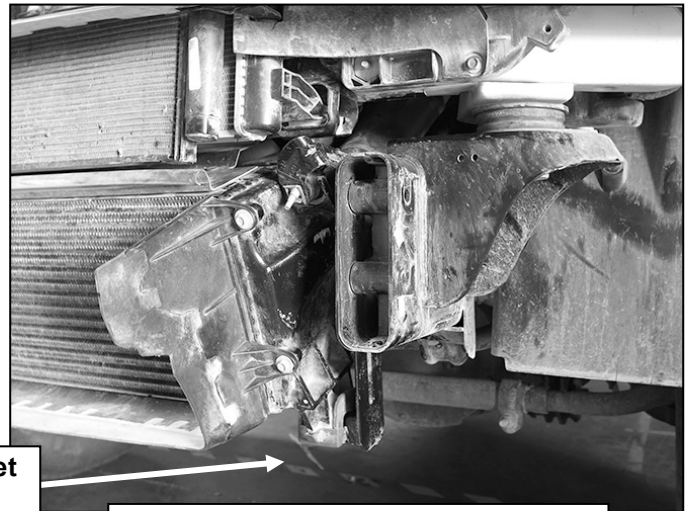

Attach Foam Washer onto the front of the factory

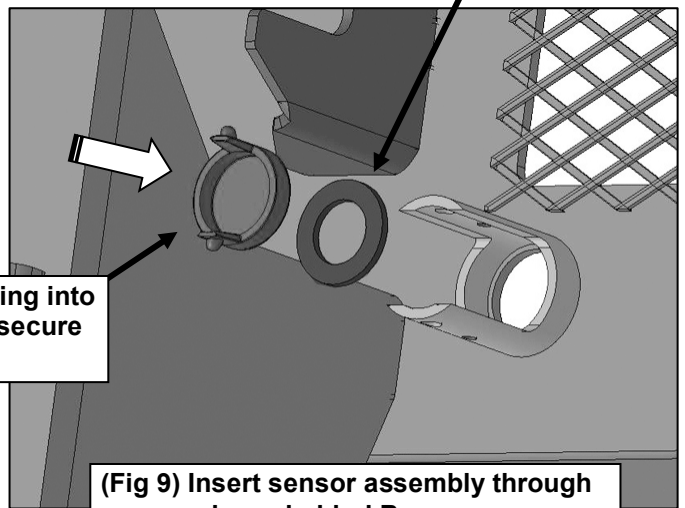

Push Retaining Ring into sensor sleeve to secure sensor in place

(Fig 9) Insert sensor assembly through sensor sleeve behind Bumper

Driver Side Installation Pictured

- (4) 12mm x 50mm Hex Bolts
- (8) 12mm Flat Washers
- (4) 12mm Nylon Lock Nuts

- Factory double bolt plate or
- (2) 12mm x 90mm Hex Bolts
- (4) 12mm Flat Washers
- (2) 12mm Nylon Lock Nuts

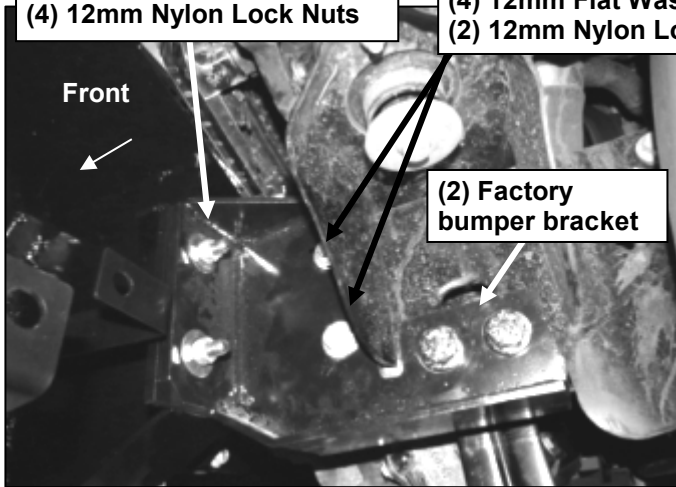

(Fig 10) Reuse factory bumper bracket hardware to attach Frame Mounting Bracket to outside of frame

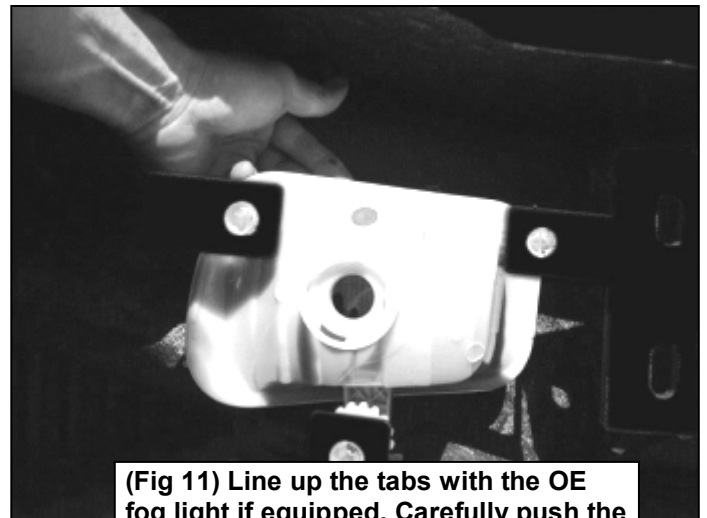

(Fig 11) Line up the tabs with the OE fog light if equipped. Carefully push the fog light into the mounting tabs

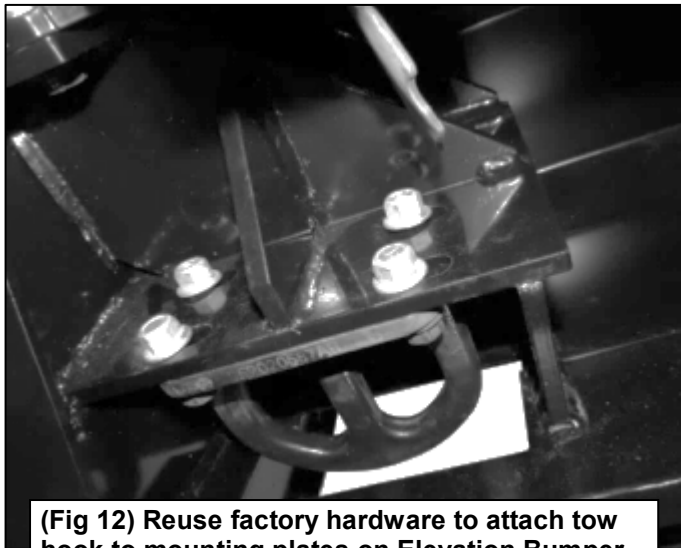

(Fig 12) Reuse factory hardware to attach tow hook to mounting plates on Elevation Bumper

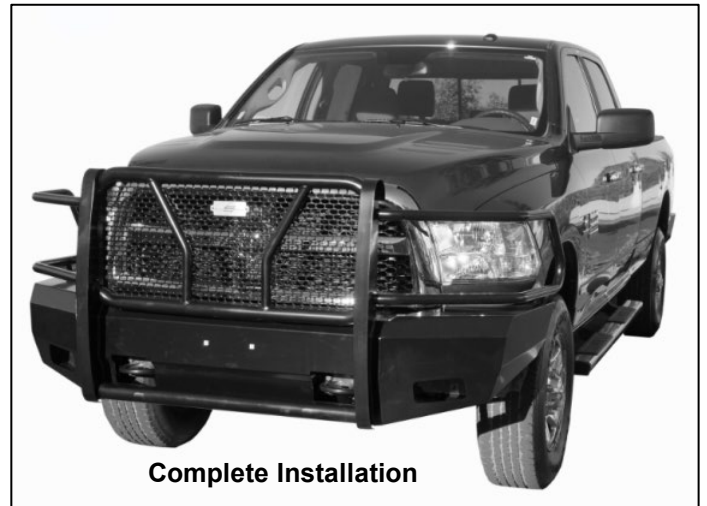

Complete Installation