

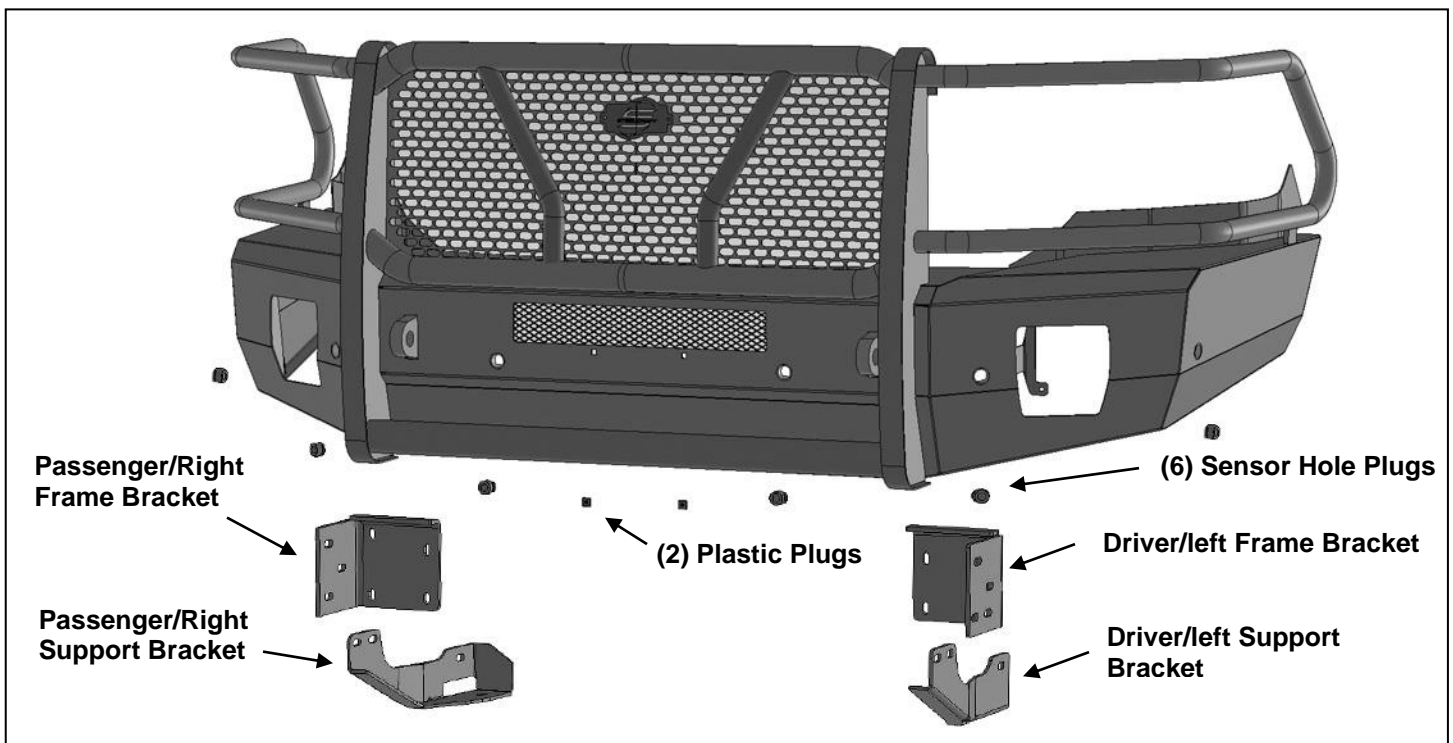

PARTS LIST:

1	Elevation Bumper Assembly	32	12mm x 37mm x 3mm STD Flat Washers
1	Driver/left Frame Mounting Bracket	2	12mm Lock Washers
1	Passenger/right Frame Mounting Bracket	16	12mm Nylon Lock Nuts
1	Driver/left Support Bracket	2	10-1.5mm x 40mm Hex Bolts
1	Passenger/right Support Bracket	4	10mm x 30mm OD x 2.5mm Flat Washers
2	Plastic Plugs for license plate mount	2	10mm Nylon Lock Nuts
6	Sensor Hole Plugs	6	6-1.00mm x 25mm Hex Bolts
2	12-1.5mm x 35mm Special Fine Thread Hex Bolts	12	6mm x 18mm x 1.6mm Flat Washers
2	12-1.75mm x 130mm Hex Bolts	6	6mm Nylon Lock Nuts
14	12-1.75mm x 55mm Hex Bolts	12	4mm x 10mm Button Head Bolts
2	12mm x 44mm x 4mm Large Flat Washer	1	4mm Allen Wrench



PROCEDURE:

REMOVE CONTENTS FROM BOX. VERIFY ALL PARTS ARE PRESENT. READ INSTRUCTIONS CAREFULLY BEFORE STARTING INSTALLATION. BUMPER IS HEAVY, ASSISTANCE IS HIGHLY RECOMMENDED TO AVOID POSSIBLE INJURY OR DAMAGE TO THE VEHICLE.

1. Remove the license plate and bracket.
2. Next, remove the plastic fascia fill panel between the headlights and the top of the bumper. **NOTE:** Release inner fender liner to access hardware attaching the ends of fascia panel to the bottom of the front fenders, **(Figures 1—3)**. On some model years, it may be necessary to temporarily remove the grille to remove the fascia or 1pc plastic bumper cover.
3. On models with factory fog lights and/or sensors, unplug wiring harness leading to the bumper, **(Figure 4)**. Release the harness from the clips attached to the back of the bumper and move harness away.
4. On models equipped with tow hooks, remove the tow hooks and mounting brackets. **NOTE:** Tow hooks cannot be reinstalled.
5. Place blocks or jack stands under the front bumper to support it during mounting bolt removal. Once the bumper has been safely supported, remove the (3) hex nuts attaching each bumper bracket to the end of the frame, **(Figure 5)**. **WARNING!** Assistance is required to hold the bumper in place during

hardware removal to prevent the bumper from falling. Slide the bumper assembly off of the end of the frame.

6. Next, remove the plastic inner support blocks from the bottom of the grille and headlights, **(Figure 6)**.
7. Select the driver/left side Frame Mounting Bracket, **(Figure 7)**. **NOTE:** Holes in mounting flange on end of frame are two sizes (3-large, 1-small). Attach the Bracket to the end of the frame with (3) 12mm x 55mm Hex Bolts, (6) 12mm Flat Washers and (3) 12mm Nylon Lock Nuts. Use (1) 10mm x 40mm Hex Bolt, (2) 10mm Flat Washers and (1) 10mm Nylon Lock Nut to attach the Bracket to the smaller, top inner mounting hole in the bumper flange, **(Figures 7 & 8)**.
8. Select the driver/left Support Bracket, **(Figure 9)**. Line up the forward end of the Support Bracket with the inside of the Frame Bracket. Insert (1) 12mm x 130mm Hex Bolt with (1) 12mm STD Flat Washer through the Support Bracket first and through the frame extension. Secure the Support Bracket to the frame extension with (1) 12mm x 44mm Large Flat Washer and (1) 12mm Nylon Lock Nut. Attach the Support Bracket to the bottom of the frame extension with (1) 12-1.5mm x 35mm **Special Fine Thread Hex Bolt**, (1) 12mm Lock Washer and (1) 12mm STD Flat Washer, **(Figures 9 & 10)**. Snug but do not fully tighten hardware at this time. **IMPORTANT:** Do not overtighten the long 12mm Hex Bolt.
9. Repeat **Steps 7 & 8** to install the passenger/right side Frame and Support Brackets.
10. **Optional Center LED light installation** (sold separately). **NOTE:** It may be easier to install the center light (not included) and sensors on the Bumper before Bumper Assembly is attached to the vehicle.
 - a. Attach the light to the (2) tabs on the back of the Bumper.
 - b. Follow light manufacturer's instructions to adjust and wire the light once Bumper has been fully installed.

Models without bumper sensors:

- a. Select the included (6) Rubber Plugs.
- b. From behind bumper, push plugs into sensor mounting holes, **(Figure 11)**.

Models with bumper mounted sensors:

- a. Push the sensor into the mounting socket in the back of the bumper.
- b. Secure each sensor to the socket with (2) 4mm x 10mm Button Head Screws, **(Figure 11)**.
IMPORTANT: Sensors fit snug in sockets. The 4mm Screws are used to apply slight pressure to lock the sensors in place. Tighten both screws evenly until they touch the sensor body only. Do not overtighten screws or damage to sensors will result.

11. With assistance, position the Bumper Assembly up to the outside of the Frame Brackets, **(Figure 12)**. Temporarily support the weight of the Bumper. **WARNING:** To avoid possible injury or damage to the vehicle, do not proceed until the Bumper is fully and safely supported.
12. Line up the (4) holes in the driver side mounting plate on the inside of the Bumper with the slots in the Frame Bracket and Support Bracket. Attach the Bumper to the Brackets with the included (4) 12mm x 55mm Hex Bolts, (8) 12mm Flat Washers and (4) 12mm Nylon Lock Nuts, **(Figures 12 & 13)**. Do not fully tighten hardware at this time. Repeat this **Step** to attach the passenger side of the Bumper to the Brackets.
13. Level and adjust the bumper and fully tighten all 12mm hardware to 65-70ft-lbs.
14. **Models with fog lights:**
 - a. Attach each light assembly with plastic housing to the mounting tabs on the back of the bumper with (3) 6mm x 25mm Hex Bolts, (6) 6mm Flat Washers and (3) 6mm Nylon Lock Nuts, **(Figure 14)**.
IMPORTANT: Do not overtighten hex bolts to avoid damaging plastic light mount.
15. Reattach the factory wiring harness to both lights and/or sensors if equipped.
16. Use the included (2) push-in Plastic Nuts to attach the front license plate, (if required), to the (2) holes in the front of the Bumper, **(Figure 15)**.
17. Do periodic inspections to the installation to make sure that all hardware is secure and tight.

To protect your investment, wax this product after installing. Regular waxing is recommended to add a protective layer over the finish. Do not use any type of polish or wax that may contain abrasives that could damage the finish. Mild soap may be used to clean the Bumper assembly.

Driver Side Installation Pictured



(Fig 1) Remove hardware attaching plastic fender liner to fender



(Fig 2) Pull back fender liner to locate fascia attachment at bottom of front fender



(Fig 3) Remove fascia body panel from top of bumper, (arrows) or 1pc plastic bumper cover

WARNING! Do not remove bumper bolts unless the bumper is properly supported on blocks or stands or the bumper may fall.



(Fig 4) Unplug lights and sensors if equipped. Unplug harness to bumper and move harness

Driver Side Installation Pictured

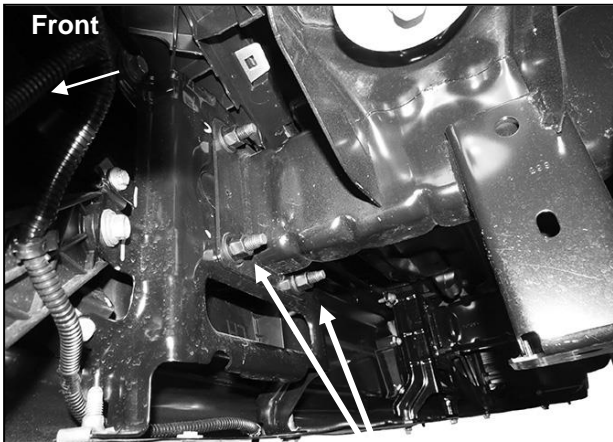

(Fig 5) Remove (3) factory hex nuts from each side

10mm x 40mm Hex Bolt
(2) 10mm Flat Washers
10mm Nylon Lock Nut

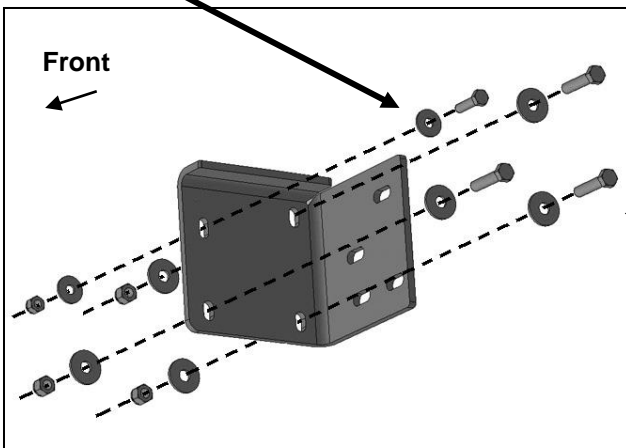

(Fig 7) Attach driver/left Bracket to end of frame

10mm x 40mm Hex Bolt
(2) 10mm Flat Washers
10mm Nylon Lock Nut

WARNING! Do not crawl under bumper unless the bumper is properly supported on blocks or stands or the bumper may fall.

WARNING! Do not remove bumper bolts unless the bumper is properly supported on blocks or stands or the bumper may fall.

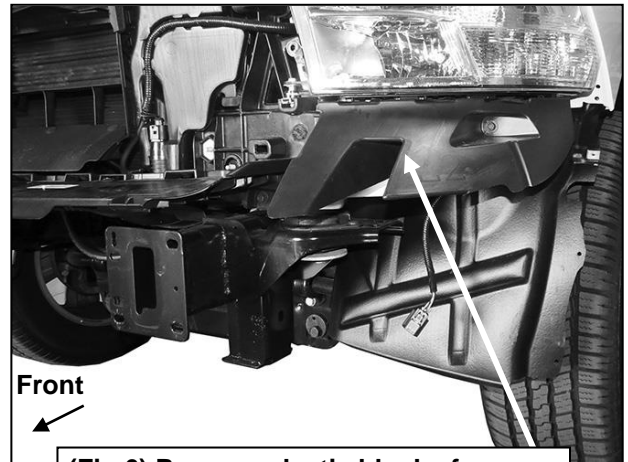

(Fig 6) Remove plastic blocks from below headlight and from below grille

(3) 12mm x 55mm Hex Bolts
(6) 12mm STD Flat Washers
(3) 12mm Nylon Lock Nuts

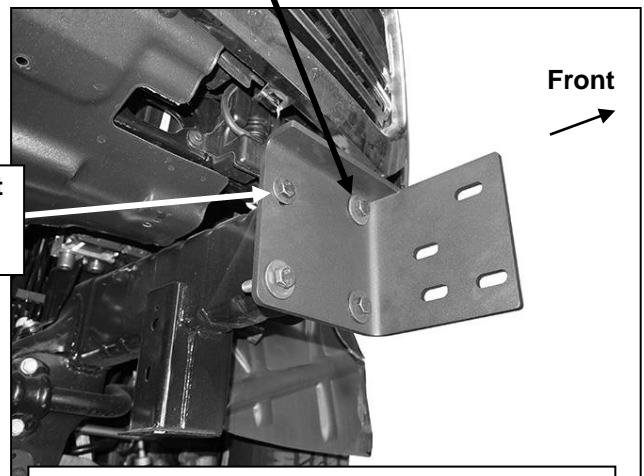

(Fig 8) Driver/left Mounting Bracket installed

Driver Side Installation Pictured

12mm x 44mm Large Flat Washer
12mm Nylon Lock Nut

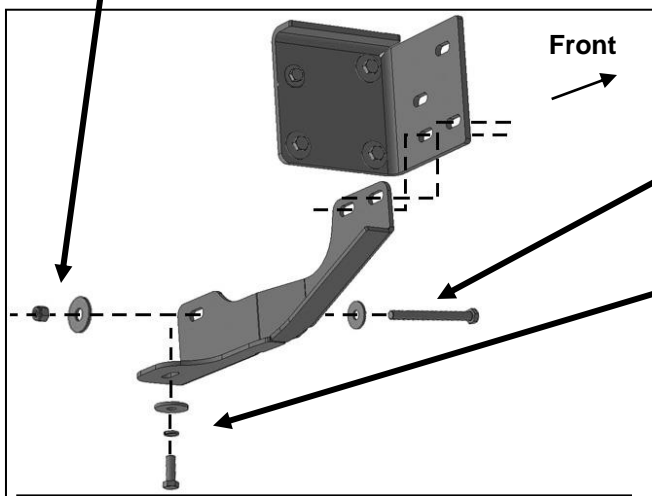

(Fig 9) Attach driver/left Support Bracket to bottom of frame extension and Frame Bracket

12mm x 130mm Hex Bolt
12mm STD Flat Washer

12-1.5mm x 35mm Special Fine Thread Hex Bolt
12mm Lock Washer
12mm STD Flat Washer

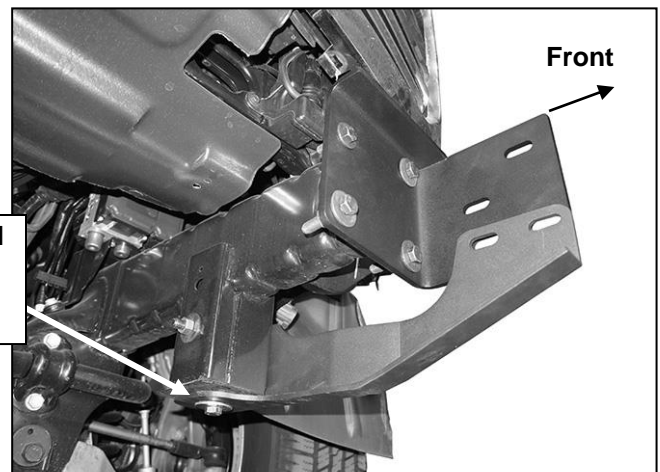

(Fig 10) Driver/left complete Bracket installation

12-1.5mm x 35mm Special Fine Thread Hex Bolt
12mm Lock Washer
12mm STD Flat Washer

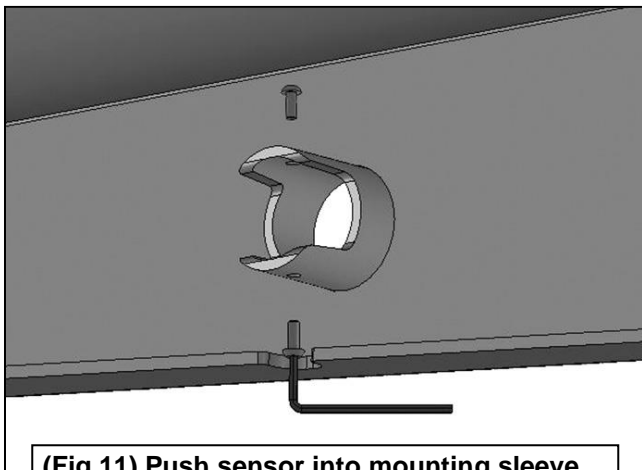

(Fig 11) Push sensor into mounting sleeve. Use 4mm Screws to lock sensor in place.

IMPORTANT: Sensors fit snug in sockets. The 4mm Screws are only used to apply slight pressure to lock the sensors in place. Tighten both screws evenly until they touch the sensor body only. Do not overtighten screws or damage to sensors will result.

WARNING! Do not crawl under bumper unless the bumper is properly supported on blocks or stands or the bumper may fall.

(4) 12mm x 55mm Hex Bolts
(8) 12mm STD Flat Washers
(4) 12mm Nylon Lock Nuts

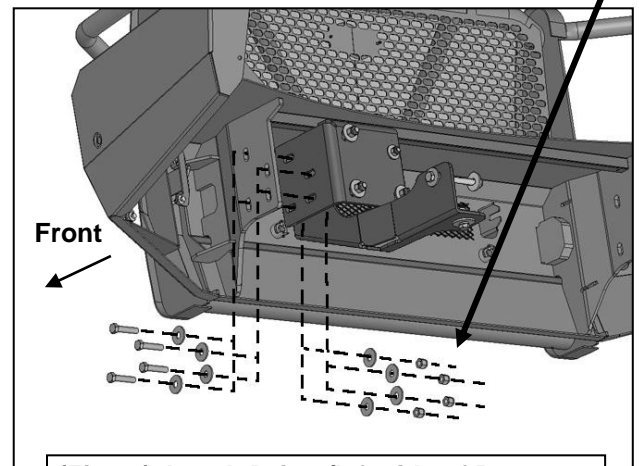

(Fig 12) Attach Driver/left side of Bumper assembly to Bracket assembly (Figure 10)

Driver Side Installation Pictured

- (4) 12mm x 55mm Hex Bolts**
- (8) 12mm STD Flat Washers**
- (4) 12mm Nylon Lock Nuts**

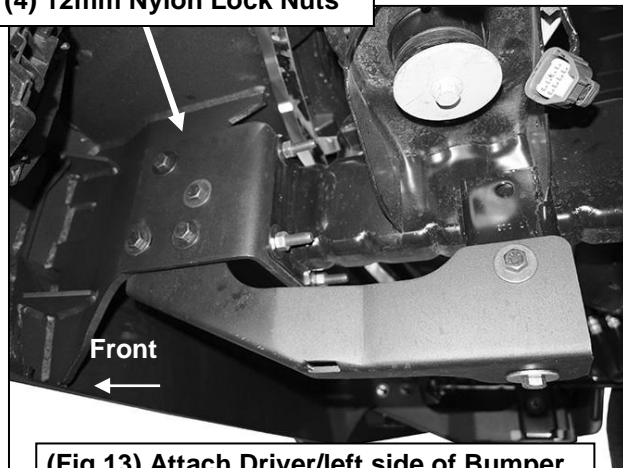

(Fig 13) Attach Driver/left side of Bumper assembly to Bracket assembly (Figure 10)

- (3) 6mm x 20mm Hex Bolts**
- (6) 6mm Flat Washers**
- (3) 6mm Nylon Lock Nuts**

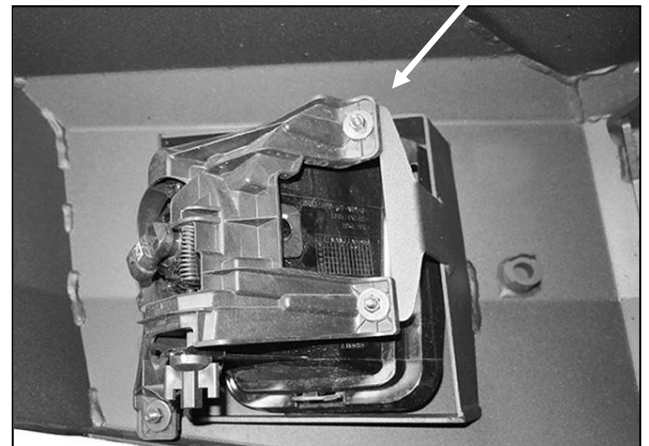

(Fig 14) Attach factory fog light assembly (if equipped) to mounting brackets on back of Bumper

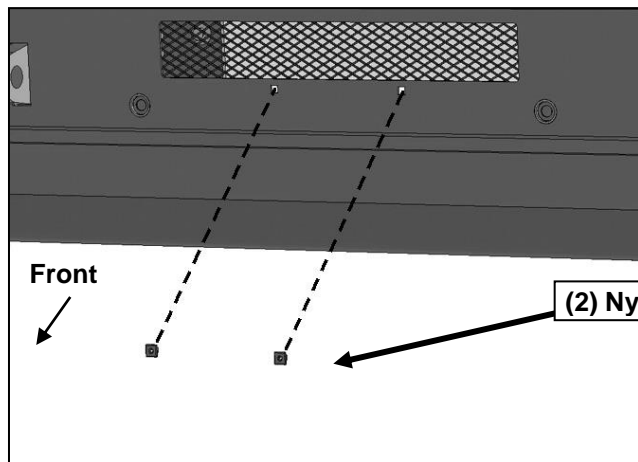

- (2) Nylon Nuts**

(Fig 15) Attach License Plate Plugs to Bumper



Complete Installation (accessories pictured available separately)