



# **INSTALLATION INSTRUCTIONS**

**ELEVATION FRONT BUMPER  
2017 FORD SUPER DUTY F250-350**

**PARTS LIST:**

1	Elevation Front Bumper Assembly	36	12mm x 32mm x 3mm Flat Washers
1	Driver/left Frame Bracket	22	12mm Lock Washers
1	Passenger/right Frame Bracket	22	12-1.75mm Hex Nuts
2	Plastic Plugs for license plate mount	2	8-1.25mm x 20mm Hex Bolts
1	Driver/left Upper U-Bracket (OEM fog light)	4	8mm x 24mm x 2mm Flat Washers
1	Passenger/right Upper U-Bracket (OEM fog light)	2	8mm Nylon Lock Nuts
2	Lower U-Brackets (OEM fog light only)	4	6mm x 16mm Hex Bolts
8	12mm x 50mm Bolt Plates	4	6mm x 18mm x 1.6mm Flat Washers
14	12-1.75mm x 50mm Hex Bolts	4	6mm Lock Washers

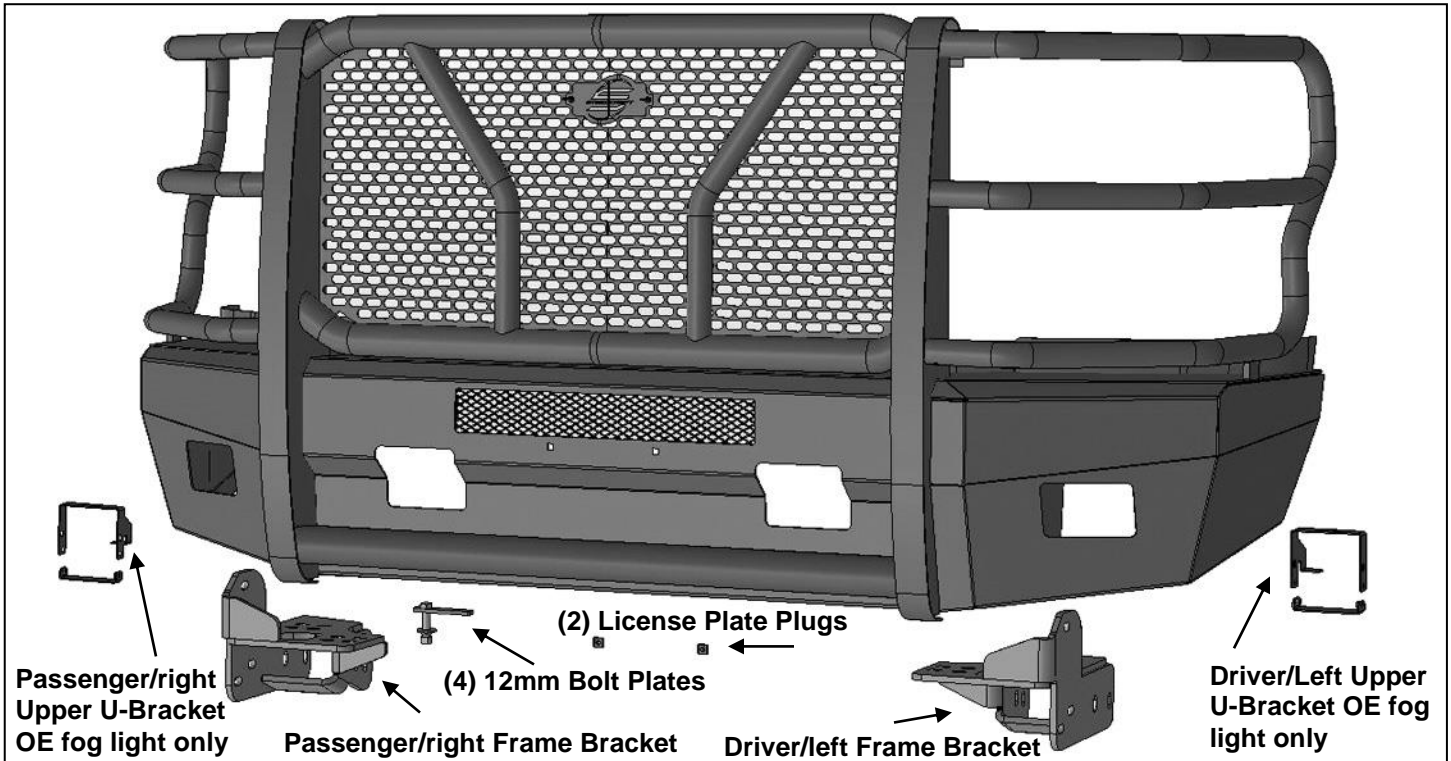

**PROCEDURE:**

**REMOVE CONTENTS FROM BOX. VERIFY ALL PARTS ARE PRESENT. READ INSTRUCTIONS CAREFULLY BEFORE STARTING INSTALLATION. BUMPER IS HEAVY, ASSISTANCE IS HIGHLY RECOMMENDED TO AVOID POSSIBLE INJURY OR DAMAGE TO THE VEHICLE.**

1. Remove the license plate and bracket. On models with factory fog lights, unplug both lights. Release the wiring harness from the clips attached to the back of the bumper, **(Figures 1 & 2)**. Move harness away from bumper.
2. Next, remove the plastic lower air dam from the bottom of the bumper, **(Figure 3)**. Remove the outer bumper supports attaching the outer ends of the bumper to the sides of the frame, **(Figure 4)**. Remove the plastic covers from the tow hooks to uncover the bumper bolts, **(Figure 5)**.
3. Place blocks or jack stands under the front bumper to support it during mounting bolt removal. Once the bumper has been safely supported, remove the (8) factory bumper bolts, **(Figure 6)**. **WARNING!** Assistance is required to hold the bumper in place during bolt removal to prevent the bumper from falling. Carefully slide the bumper off over the tow hooks.
4. Remove the tow hooks from the ends of the frame, **(Figure 7)**. Next, remove the factory hex nuts, lower frame extension and double bolt plates from the ends of the frame, **(Figures 2 & 7)**.

5. Select the driver/left Frame Bracket. Slide the Bracket over the end of the frame. Line up the slots in the sides of the Bracket with the holes in the frame. Select (4) 12mm Bolt Plates. Insert the Bolt Plates into the open end of the frame and out through the Bracket. Attach the Bracket to the Bolt Plates with (4) 12mm Flat Washers, (4) 12mm Lock Washers and (4) 12mm Hex Nuts, **(Figures 8 & 9)**. Leave hardware loose at this time.
6. Attach the mounting tab on the top of the Bracket to the top of the frame with the included (4) 12mm x 50mm Hex Bolts, (8) 12mm Flat Washers, (4) 12mm Lock Washers and (4) 12mm Hex Nuts, **(Figures 10 & 11)**. Do not fully tighten hardware at this time.
7. Reuse the factory hardware to attach the tow hook to the bottom of the mounting tab on the Frame Bracket, **(Figure 12)**.
8. Repeat **Steps 5—7** to install the passenger/right Frame Bracket and tow hook.
9. With assistance, carefully position the Bumper Assembly up to the Brackets. Temporarily support the weight of the Bumper. **WARNING:** To avoid possible injury or damage to the vehicle, do not proceed until the bumper is fully and safely supported.
10. Line up the (3) holes in the driver/left side of the Bumper with the (3) holes in the Frame Bracket. Attach the Bumper to the Bracket with the included (3) 12mm x 50mm Hex Bolts, (6) 12mm Flat Washers, (3) 12mm Lock Washers and (3) 12mm Hex Nuts, **(Figures 13 & 14)**. Do not fully tighten hardware at this time. Repeat to attach the passenger/right side of the Bumper to the Bracket.
11. Level and adjust the bumper and fully tighten all 12mm hardware to 65-70ft-lbs.
12. Use the included (2) push-in plastic nuts to attach the front license plate, (if required), to the (2) holes in the front bumper, **(Figure 15)**.
13. **Models with factory fog lights:**
  - a. Use a flat blade screwdriver to carefully pop out the tabs on the side of the fog light bracket attaching the light to the bracket, **(Figure 1)**. Pop the light out of the plastic bracket housing.
  - b. Remove the adjustment screw and spring from the light assembly.
  - c. Select the driver/left top U Bracket, **(Figure 16)**. Attach the Bracket to the slot in the light opening with the included (1) 8mm Hex Bolt, (2) 8mm Flat Washers and (1) 8mm Nylon Lock Nut, **(Figure 16)**.
  - d. Carefully spread the sides of the Bracket enough to slide the OE plastic fog light between and into the Bracket, **(Figure 17)**. Select (1) Lower U-Bracket. Attach the Lower Bracket to the Upper Bracket with (2) 6mm Hex Bolts, (2) 6mm Lock Washers and (2) 6mm Flat Washers, **(Figure 18)**.
  - e. Insert the factory spring between the tab on the Bracket and the light. Insert the screw through the tab, spring and into the fog light, **(Figure 18)**.
  - f. Repeat to install the passenger/right fog light.
14. Reattach the factory wiring harness. Adjust lights as necessary and tighten all fog light bracket hardware.
15. Do periodic inspections to the installation to make sure that all hardware is secure and tight.

**To protect your investment**, wax this product after installing. Regular waxing is recommended to add a protective layer over the finish. Do not use any type of polish or wax that may contain abrasives that could damage the finish. Mild soap may be used to clean the HD Front Bumper assembly.



(Fig 1) On models with fog lights, unplug wire harness from back of light

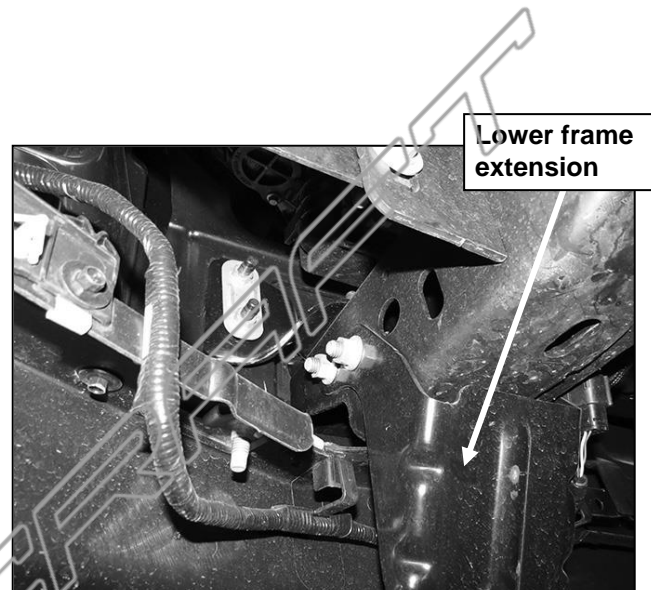

(Fig 2) Release clips attaching the wire harness for fog lights if equipped (driver side)



(Fig 3) Remove plastic air dam from bumper

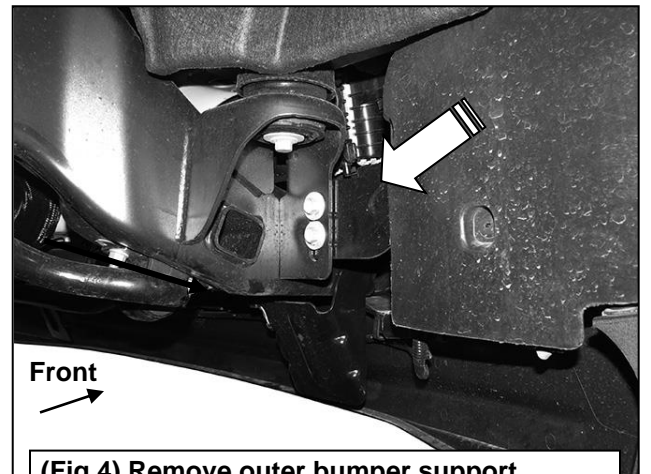

(Fig 4) Remove outer bumper support brackets between frame and bumper (arrow)

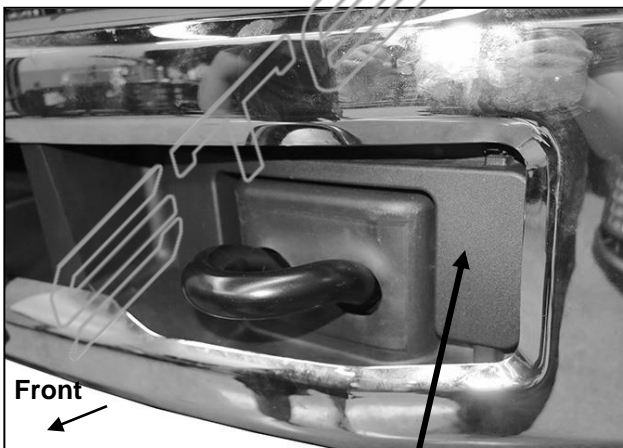

(Fig 5) Remove plastic cover around tow hook

**WARNING!** Do not remove bumper bolts unless the bumper is properly supported on blocks or stands or the bumper may fall.

Driver/left Side Installation Pictured



(Fig 6) Remove bumper bolts (driver side pictured)

**WARNING!** Do not crawl under bumper unless the bumper is properly supported on blocks or stands or the bumper may fall.

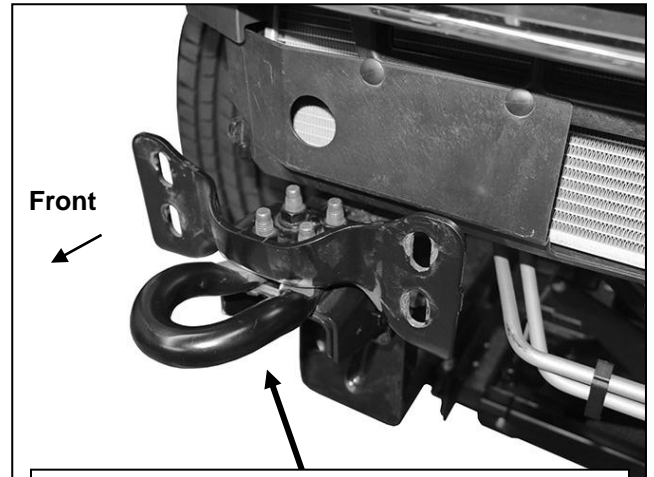

(Fig 7) Remove tow hook assembly and lower frame extension (not pictured-see Fig 2)

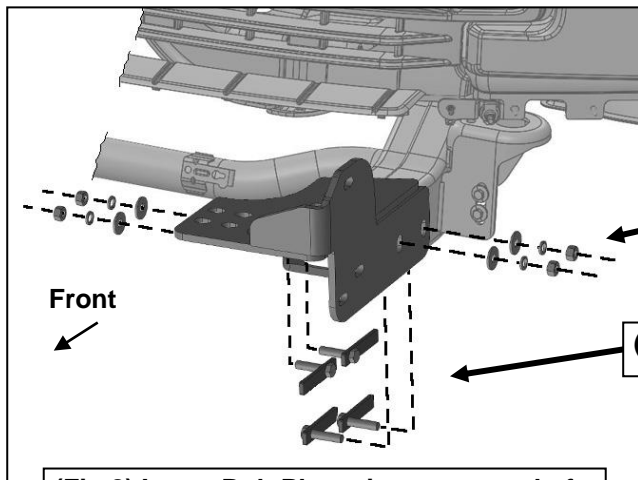

- (4) 12mm Flat Washers
- (4) 12mm Lock Washers
- (4) 12mm Hex Nuts

- (4) 12mm Bolt Plates

Front  
↙

(Fig 8) Insert Bolt Plates into open end of frame. Attach Bracket to sides of frame

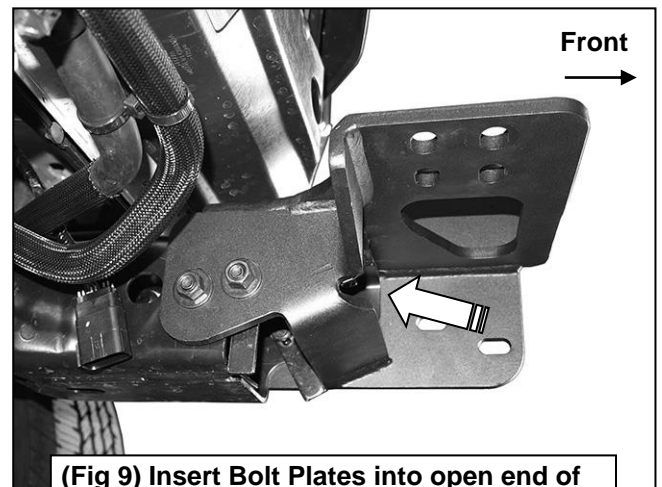

(Fig 9) Insert Bolt Plates into open end of frame (driver/left frame Bracket pictured)

Front  
→

Driver/left Side Installation Pictured

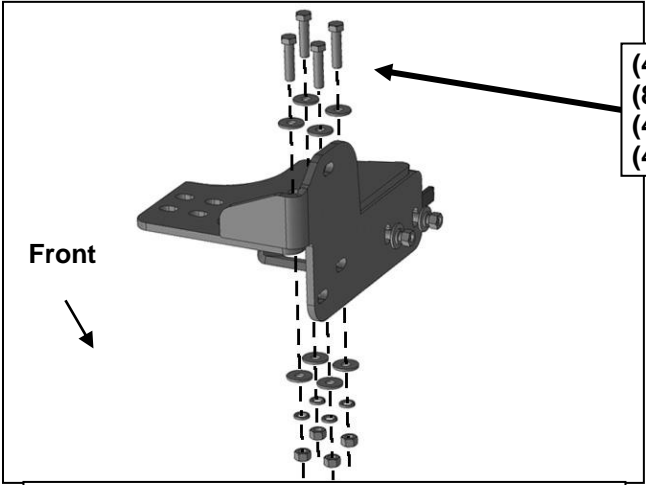

(Fig 10) Attach top of Bracket to top of frame

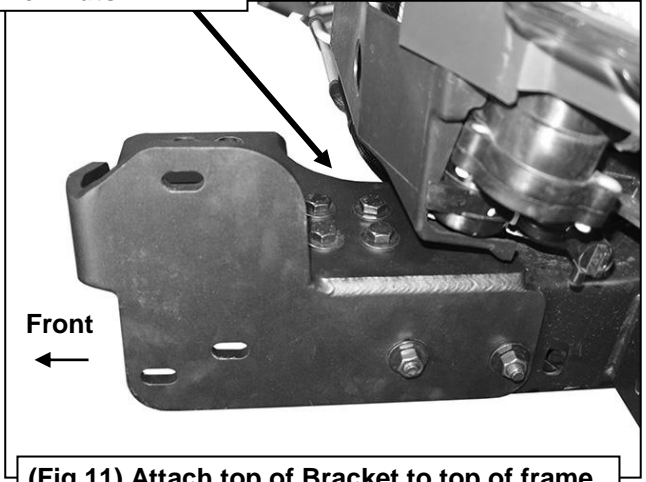

(Fig 11) Attach top of Bracket to top of frame

**WARNING!** Do not crawl under bumper unless the bumper is properly supported on blocks or stands or the bumper may fall.

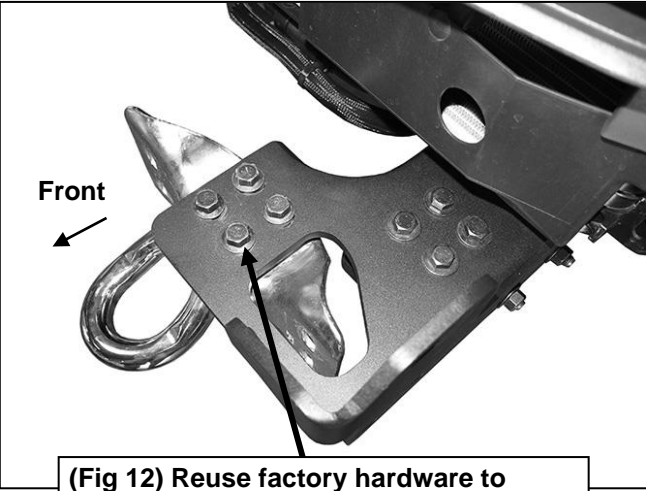

(Fig 12) Reuse factory hardware to attach tow hook to mount on Bracket

- (3) 12mm x 50mm Hex Bolts
- (6) 12mm Flat Washers
- (3) 12mm Lock Washers
- (3) 12mm Hex Nuts

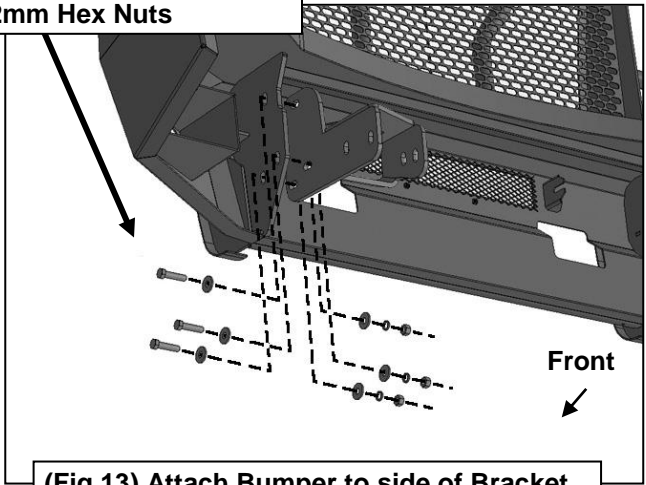

(Fig 13) Attach Bumper to side of Bracket

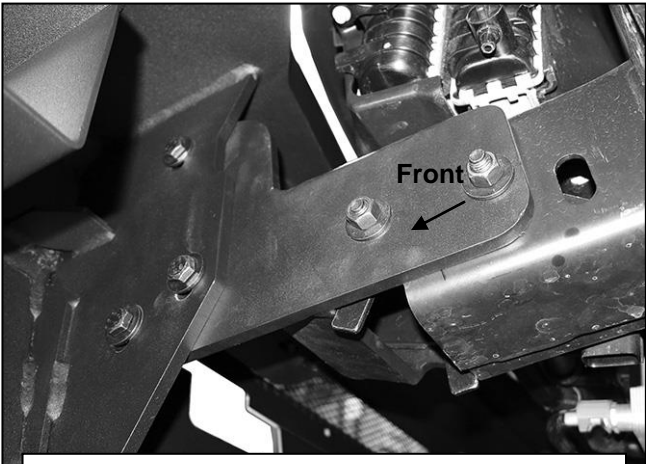

(Fig 14) Attach Bumper to side of Bracket (driver/left side pictured from behind bumper)

Driver/left Side Installation Pictured

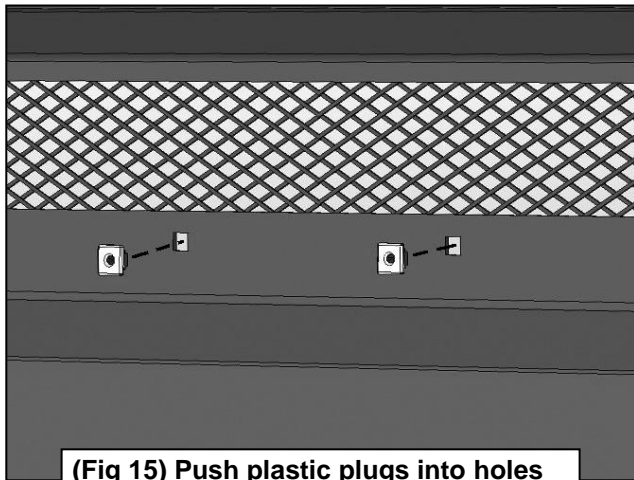

(Fig 15) Push plastic plugs into holes in Bumper for license plate if required

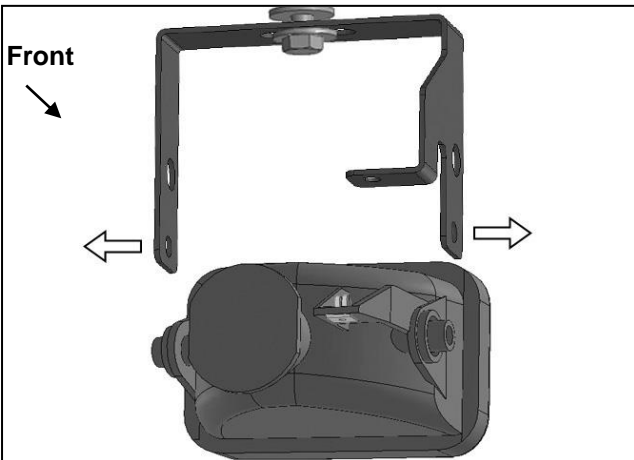

(Fig 17) Carefully spread sides to slide OEM fog light into position in pivot holes

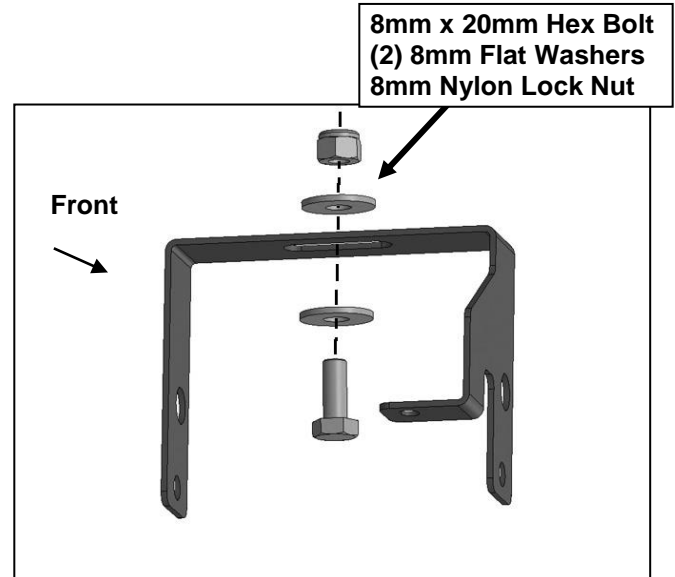

(Fig 16) Optional OEM fog light installation (light not included). Attach driver/left Upper Bracket to the slot in top of the opening

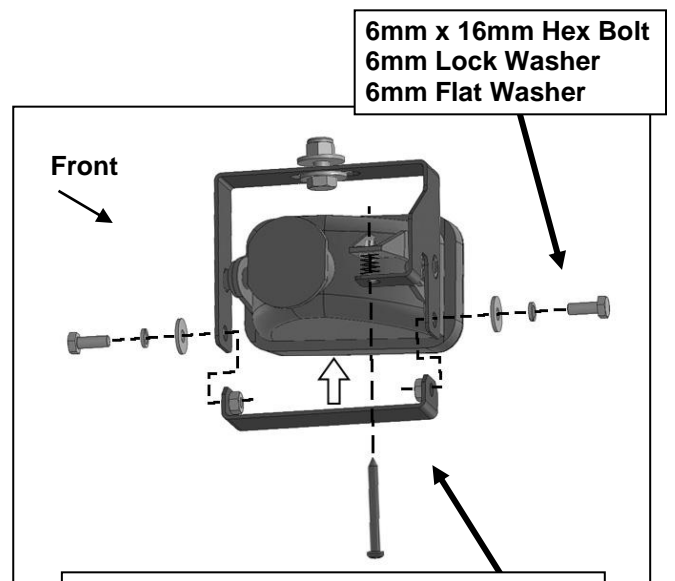

(Fig 18) Attach lower U Bracket to Upper Bracket. Reuse factory adjustment hardware (screw, spring and plastic nut)