

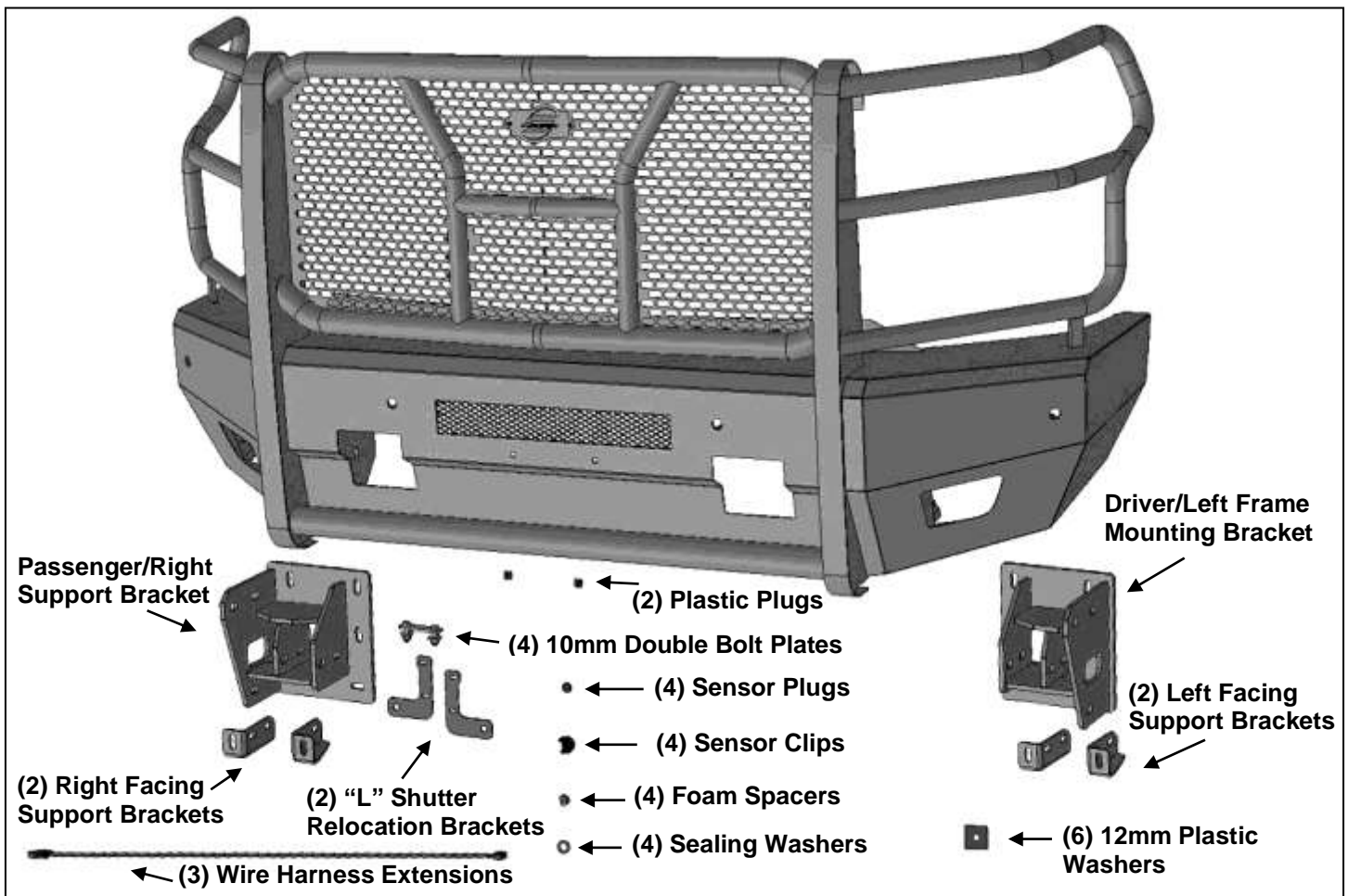

**ALUMINUM ELEVATION FRONT BUMPER  
2020-2022 CHEVY SILVERADO 25-3500**

**PARTS LIST:**

1	Elevation Front Bumper	4	12-1.75mm x 130mm Hex Bolts
1	Driver/left Mounting Bracket	18	12-1.75mm x 50mm Hex Bolts
1	Passenger/right Mounting Bracket	44	12mm x 32mm x 3mm Flat Washers
2	Left Facing Support Bracket	22	12mm Nylon Lock Nuts
2	Right Facing Support Bracket	4	10mm x 35mm Double Bolt Plates
2	Shutter Relocation "L" Brackets	8	10mm x 27mm x 3mm Flat Washers
4	Sensor Hole Plugs	8	10mm Nylon Lock Nut
4	Sealing Washers	10	6-1.0mm x 20mm Hex Bolts
4	20mm x 10mm Foam Spacers	20	6mm x 18mm x 1.6mm Flat Washers
4	Retaining Caps	10	6mm Nylon Lock Nuts
3	Sensor Wiring Harness Extensions	8	4mm x 10mm Button Head Screws
1	Sensor Cover Kit	1	2.5mm Wrench
2	Plastic Plugs for License Plate		



**PROCEDURE:**

**REMOVE CONTENTS FROM BOX. VERIFY ALL PARTS ARE PRESENT. READ INSTRUCTIONS CAREFULLY BEFORE STARTING INSTALLATION. BUMPER IS HEAVY, ASSISTANCE IS HIGHLY RECOMMENDED TO AVOID POSSIBLE INJURY OR DAMAGE TO THE VEHICLE.**

1. Start installation at the driver/left wheel opening. Remove the hardware attaching the fender liner to the front of the fender and the end of the plastic body panel, **(Figure 1)**. Carefully pull the fender flare out to release the clips attaching it to the body panel, (fascia), and end of the fender, **(Figure 2)**. Only release the forward end of the flare, it is not necessary to remove the flare. Remove the screws attaching the end of the fascia panel to the front fender, **(Figure 3)**. Repeat this Step to release the passenger/right

**ALUMINUM ELEVATION FRONT BUMPER  
2020-2022 CHEVY SILVERADO 25-3500**

end of the fascia from the fender. Pull along the center of the fascia to release the remainder of the clips and move the plastic panel to a clean surface, **(Figure 4)**.

2. Open the hood and remove the plastic cover from the top of the radiator and the grille, **(Figure 4)**. Remove the hardware attaching the grille and pull it straight out from the vehicle. On models with grille mounted camera, unplug harness leading to the camera then remove the grille, **(Figures 5 & 7)**.
3. Unplug any wiring harnesses leading to the bumper, **(Figure 6)**. Remove the license plate and bracket if equipped, **(Figure 7)**. Move all harnesses away from bumper.
4. Remove the outer bumper supports from both ends of the bumper, **(Figure 8)**.
5. Place blocks or jack stands under the front bumper to support it during mounting bolt removal. Once the bumper has been safely supported, from above the bumper, remove the (2) factory upper and lower bumper bolts from each side, **(Figure 9)**. **WARNING!** Assistance is required to hold the bumper in place during bolt removal to prevent the bumper from falling. Remove the bumper assembly.
6. Remove the factory bumper brackets and tow hooks, (if equipped), from the end of frame, **(Figures 10 & 11)**. On models with lower radiator shutter assembly, unplug and remove the assembly, **(Figure 10)**.
7. Select the driver/left Frame Mounting Bracket, **(Figure 12)**. Attach the Bracket to the mounting plate on the end of the frame with the included (4) 12mm x 50mm Hex Bolts, (8) 12mm Flat Washers and (4) 12mm Nylon Lock Nuts, **(Figures 12 & 13)**. Do not tighten hardware at this time.
8. Next, select (1) 10mm Double Bolt Plate and (1) Left Facing Lower Support Bracket, **(Figure 14)**. Insert the Bolt Plate into the open end of the frame and through the holes in the outside of the frame. Attach the Support Bracket to the Double Bolt Plate with (2) 10mm Flat Washers and (2) 10mm Nylon Lock Nuts, **(Figure 14 & 16)**. Attach the front of the Support Bracket to the back of the Mounting Bracket with (1) 12mm x 50mm Hex Bolt, (2) 12mm Flat Washers and (1) 12mm Nylon Lock Nut, **(Figure 15)**. Do not fully tighten at this time. Repeat this Step to attach Right Facing Support Bracket to the inner side of the frame and back of the Mounting Bracket, **(Figure 14, 15 & 17)**.
9. Repeat **Steps 7 & 8** to install the passenger/right Frame and Support Brackets.
10. On models equipped with lower radiator shutter system, remove shutter assembly from outer plastic housing, **(Figure 18)**. Select (1) "L" Relocation Bracket. Use the previously installed (1) 12mm x 50mm Hex Bolt, (2) 12mm Flat Washers and (1) 12mm Nylon Lock Nut to attach the Bracket to the front of the Frame Bracket and Inner Support Bracket, **(Figure 19)**. Repeat this Step to attach the remaining "L" Bracket to the passenger/right Frame Bracket. Attach the shutter assembly to the front of the "L" Brackets with the included (4) 6mm x 20mm Hex Bolts, (8) 6mm Flat Washers and (4) 6mm Nylon Lock Nuts, **(Figure 20)**. Do not overtighten the 6mm hardware or damage to the shutter assembly may result. Plug wiring harness into shutter assembly
11. Carefully remove both fog light assemblies, all sensors and the wiring harness from the back of the OE bumper, **(Figure 22)**. Note location of each sensor for correct reinstallation.

**Models without bumper sensors:**

- a. Insert (1) Hole Plug into the outer Sensor Mount, **(Figure 21)**.
- b. Repeat to plug remaining (3) mounting holes in Bumper. Continue to **Step 12**.

**Models with bumper mounted sensors:**

- a. Select the driver/left outer sensor. Remove the seal from the end of the sensor, **(Figure 23)**. Replace the seal with the included larger Foam Seal.
  - b. Push the sensor into the Mount from the back of the Bumper until it is flush with the front of the Mount.
  - c. Push (1) Foam Spacer onto the back end of the sensor, **(Figure 24)**.
  - d. Snap (1) Sensor Retaining Cap onto the Sensor Mount, **(Figure 24)**.
  - e. Repeat the previous Steps to install the remaining sensors in order from factory bumper.
  - f. Install the factory bumper wiring harness for sensors and fog lights as equipped. Run wiring harness over Brackets to reach sensors, **(Figure 25)**. **NOTE:** (3) Wire Harness Extensions have been included to extend the factory harness to reach the sensors as needed.
12. With assistance, position the Bumper Assembly up to and over the Brackets. Temporarily support the weight of the Bumper. **WARNING:** To avoid possible injury or damage to the vehicle, do not proceed until the Bumper is fully and safely supported.
  13. Attach the Bumper to the driver/left Bracket with the included (3) 12mm x 50mm Hex Bolts, (6) 12mm Flat Washers, (3) 12mm Plastic Washers and (3) 12mm Nylon Lock Nuts, **(Figures 26 & 27)**.

## ALUMINUM ELEVATION FRONT BUMPER 2020-2022 CHEVY SILVERADO 25-3500

**IMPORTANT:** Place the Plastic Washers between the 12mm Flat Washers and the mounting plate on the Bumper to minimize corrosion. Repeat this Step to attach the passenger/right side of the Bumper. Snug but do not tighten hardware.

14. Level and adjust the bumper and fully tighten all 12mm hardware to 65-70ft-lbs.
15. Select (1) tow hook if equipped. Flip the tow hook upside-down and insert it into the opening in the Bumper and into the Frame Bracket, **(Figure 28)**. Attach the tow hook to the Bracket with the included (2) 12mm x 130mm Hex Bolts, (4) 12mm Flat Washers and (2) 12mm Nylon Lock Nuts. Fully tighten the tow hook hardware. Repeat this Step to install the passenger/right tow hook.
16. **Models with fog lights:**
  - a. Remove the fog lights from the factory bumper, **(Figure 22)**.
  - b. Attach the passenger/right fog light to the mounting tabs on the back of the driver/left side of the Bumper with the included (3) 6mm x 20mm Hex Bolts, (6) 6mm Flat Washers and (3) 6mm Nylon Lock Nuts, **(Figure 29)**. Do not overtighten hardware or damage to the light may result.
  - c. Repeat the previous Steps to attach the driver/left fog light to the passenger/right side of the Bumper.
  - d. Plug wiring harness into fog lights.
17. Use the included (2) push-in Plastic Plugs to attach the front license plate, (if required), to the (2) holes in the front Bumper, **(Figure 30)**.
18. Models with grille mounted camera, remove screen from center of Bumper, **(Figure 30)**.
19. Back of Bumper is equipped with mounting tabs for LED center light. Follow manufacturer's installation and wiring instructions for proper installation.
20. Do periodic inspections to the installation to make sure that all hardware is secure and tight.

**To protect your investment,** Do not use any type of polish or wax that may contain abrasives that could damage the finish. Mild soap may be used to clean the Elevation Front Bumper assembly.

### Driver/left Side Installation Pictured

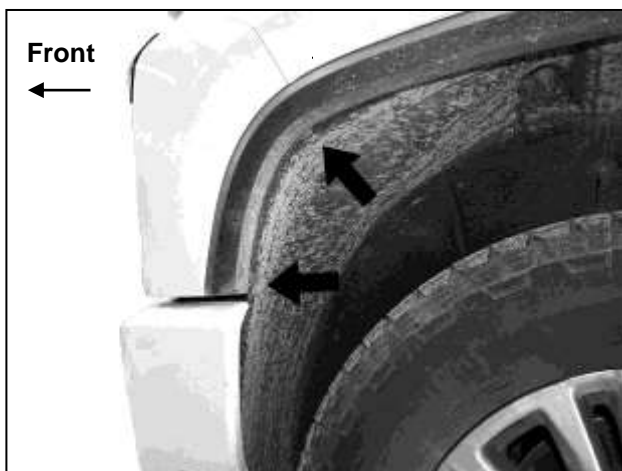

**(Fig 1)** Release hardware attaching fender liner from plastic panel (fascia-see arrows)

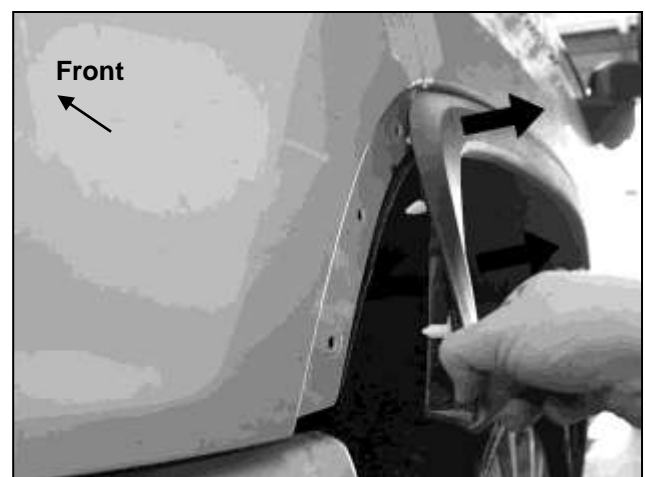

**(Fig 2)** Pull front end of fender flare out and away from fender. Do not remove flare, only release the front section

ALUMINUM ELEVATION FRONT BUMPER  
2020-2022 CHEVY SILVERADO 25-3500

Driver/left Side Installation Pictured



(Fig 3) Remove screws attaching plastic fascia panel to front end of fender (arrow)

Remove plastic cover from top of grille



(Fig 4) Remove plastic fascia from top of bumper



(Fig 5) Disconnect harness to camera (if equipped) and remove grille

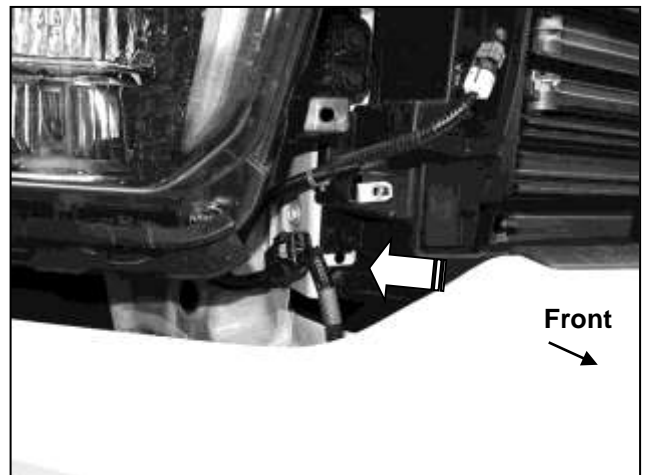

(Fig 6) Disconnect all wire harnesses leading to front bumper



(Fig 7) Grille and fascia removed

**WARNING!** Do not crawl under bumper unless it is properly supported on blocks or stands or the bumper may fall.

**ALUMINUM ELEVATION FRONT BUMPER  
2020-2022 CHEVY SILVERADO 25-3500**

**Driver/left Side Installation Pictured**

**WARNING!** Do not crawl under bumper unless it is properly supported on blocks or stands or the bumper may fall.

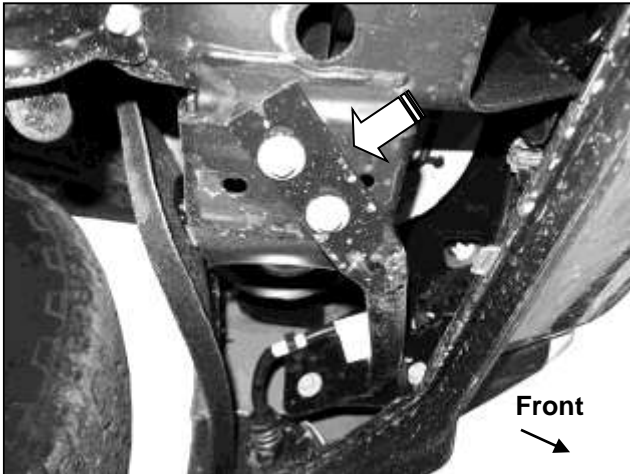

**(Fig 8) Remove driver/left and passenger/right outer bumper supports attach to bottom of frame**

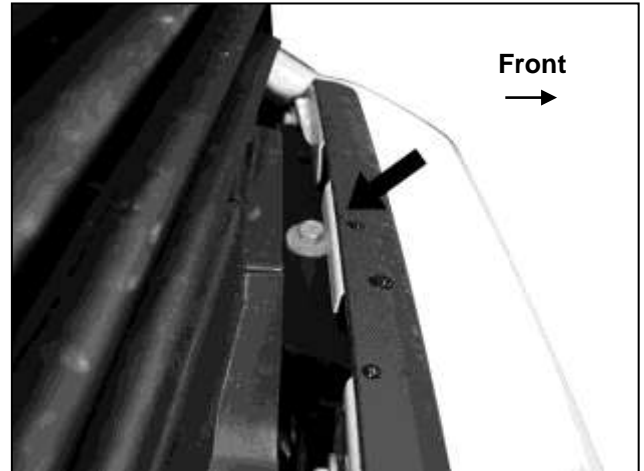

**(Fig 9) From above, remove the hex bolts attaching the bumper assembly to the frame bumper brackets (top visible-arrow)**

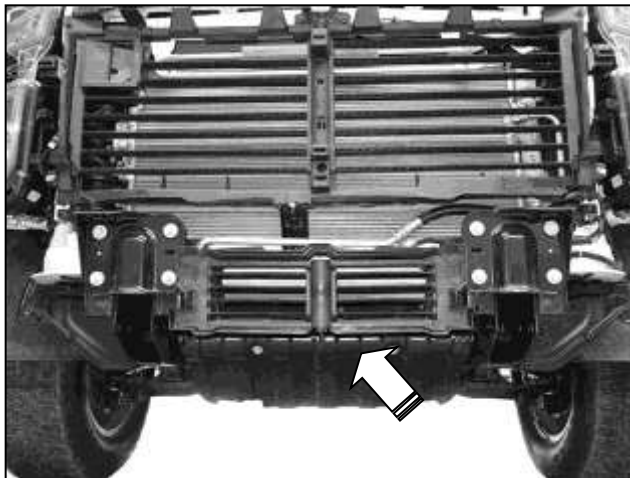

**(Fig 10) Remove tow hooks, bumper brackets and shutter assembly (arrow) if equipped**

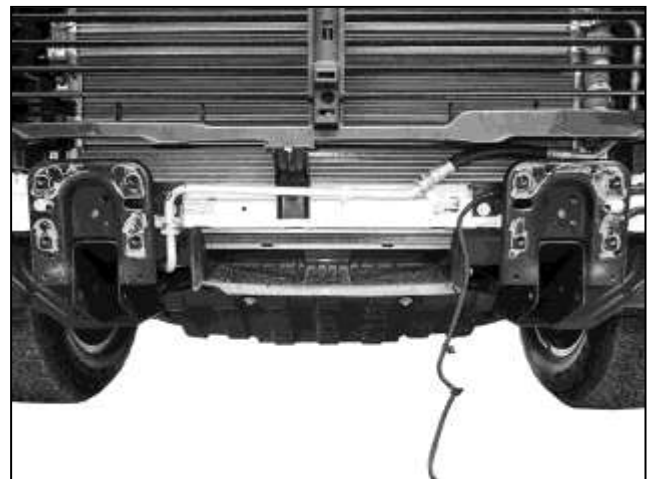

**(Fig 11) Attach Frame Brackets to end of frame**

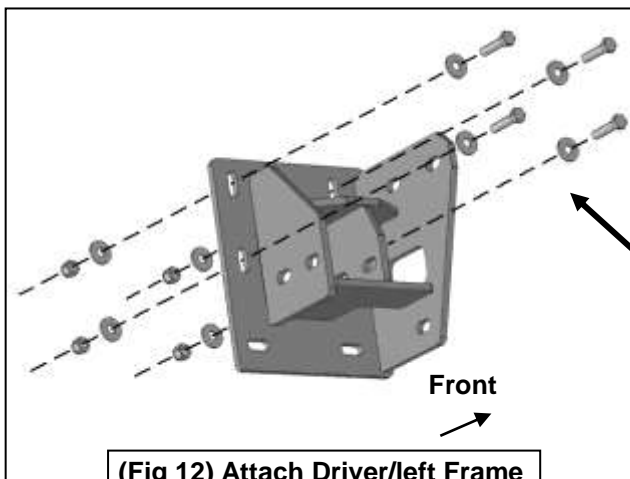

**(Fig 12) Attach Driver/left Frame Bracket to end of frame**

- (4) 12mm x 50mm Hex Bolts
- (8) 12mm Flat Washers
- (4) 12mm Nylon Lock Nuts

**ALUMINUM ELEVATION FRONT BUMPER  
2020-2022 CHEVY SILVERADO 25-3500**

**Driver/left Side Installation Pictured**

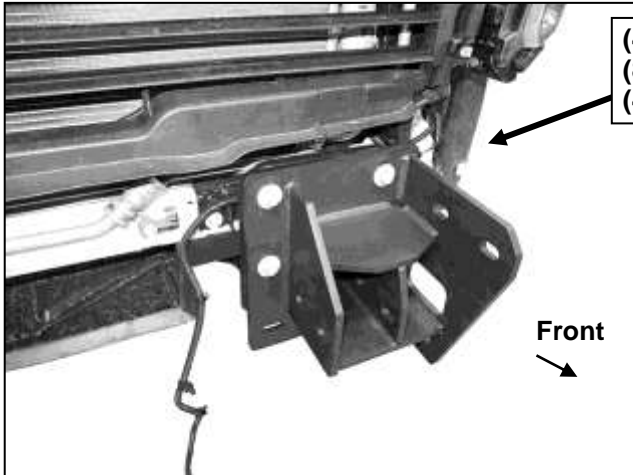

**(Fig 13) Attach Driver/left Frame Bracket to end of frame**

- (4) 12mm x 50mm Hex Bolts
- (8) 12mm Flat Washers
- (4) 12mm Nylon Lock Nuts

- 10mm Double Bolt Plate
- (2) 10mm Flat Washers
- (2) 10mm Nylon Lock Nuts

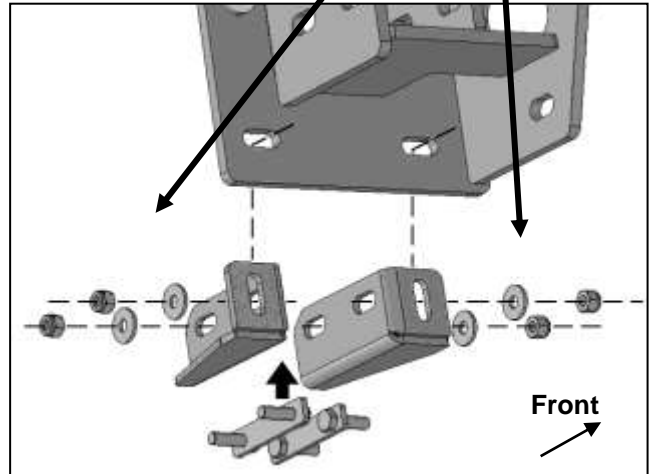

**(Fig 14) Attach (1) Left Facing and (1) Right Facing Support Bracket to the sides of the frame**

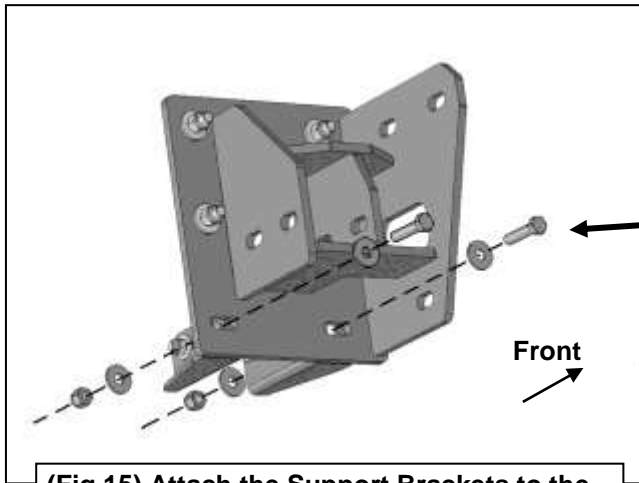

- (2) 12mm x 50mm Hex Bolts
- (4) 12mm Flat Washers
- (2) 12mm Nylon Lock Nuts

**(Fig 15) Attach the Support Brackets to the bottom slots in the driver/left Frame Bracket**

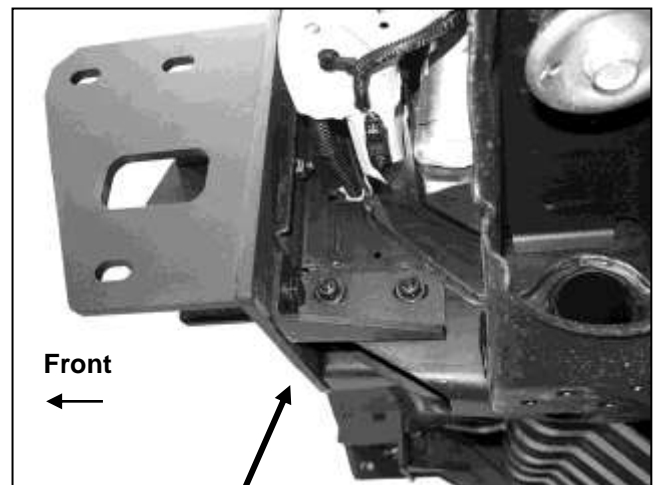

**(Fig 16) Left facing Support Bracket installed**

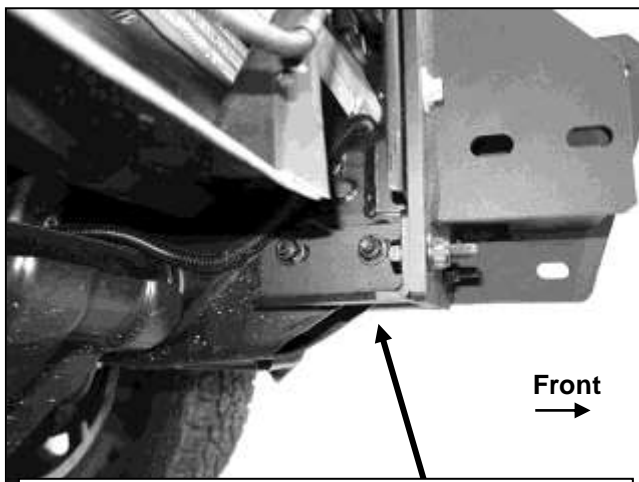

**(Fig 17) Right facing Support Bracket installed**

**ALUMINUM ELEVATION FRONT BUMPER  
2020-2022 CHEVY SILVERADO 25-3500**

**Driver/left Side Installation Pictured**

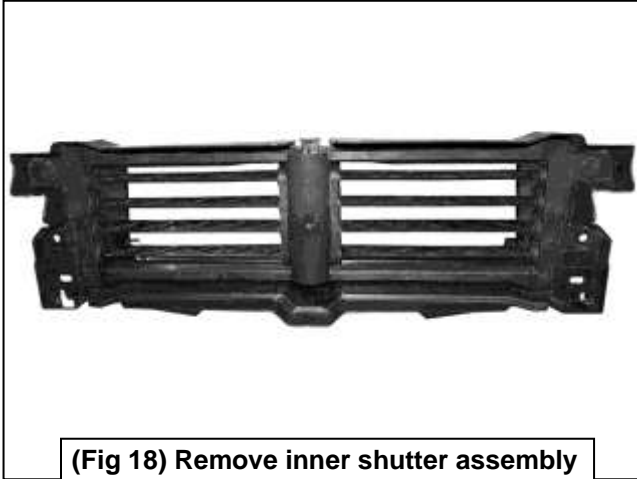

**(Fig 18) Remove inner shutter assembly from plastic outer housing (if equipped)**

- (2) 6mm x 20mm Hex Bolts**
- (4) 6mm Flat Washers**
- (2) 6mm Nylon Lock Nuts**

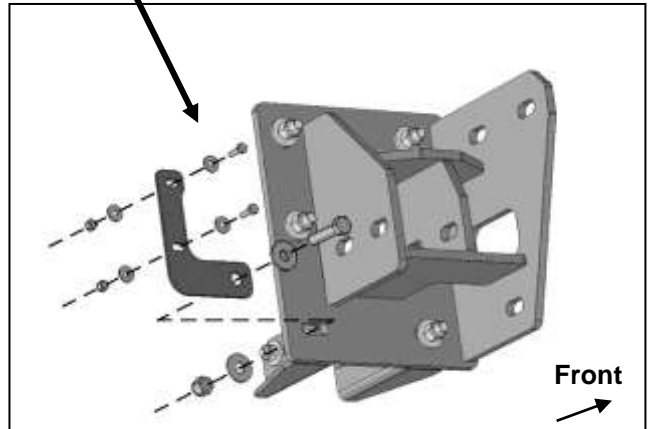

**(Fig 19) Attach "L" Relocation Brackets to front of Frame Brackets. Attach shutter assembly, (if equipped), to front of Relocation Brackets**

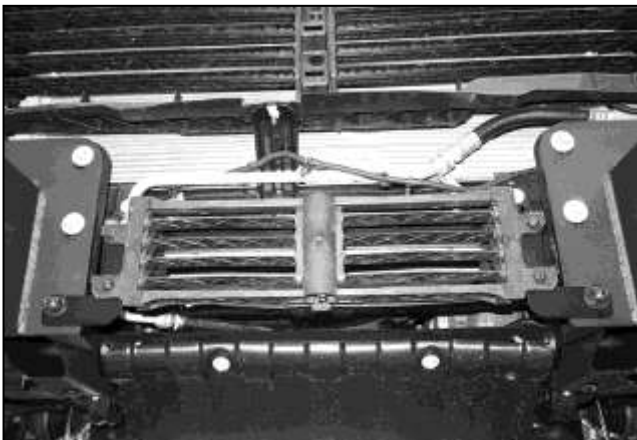

**(Fig 20) Attach shutter assembly, (if equipped), to front of Relocation Brackets**

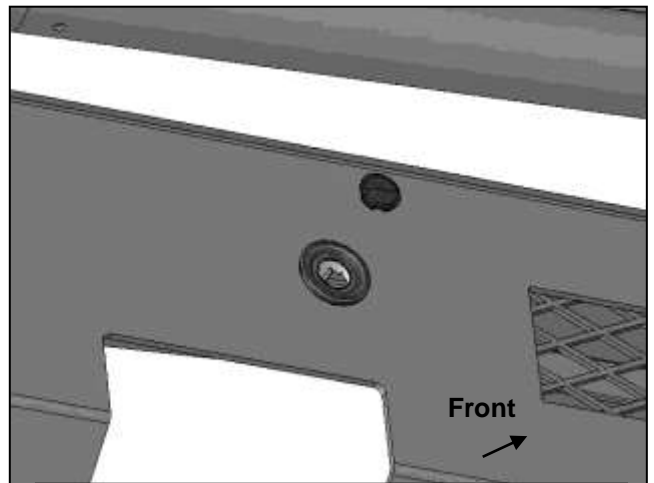

**(Fig 21) Models without sensors, insert Plug**

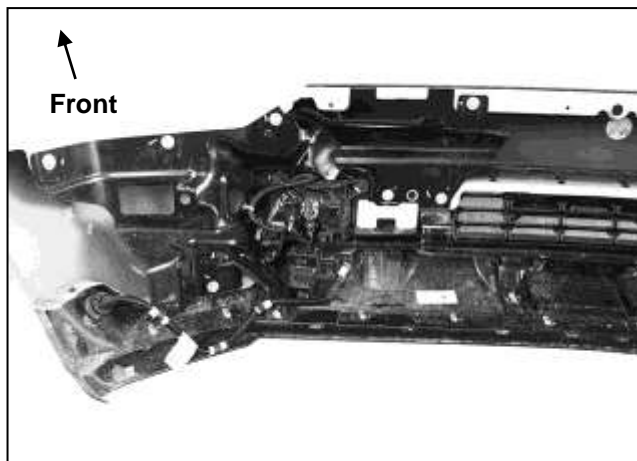

**(Fig 22) Disassemble bumper and remove fog lights, sensors and wiring harness as equipped**

**ALUMINUM ELEVATION FRONT BUMPER  
2020-2022 CHEVY SILVERADO 25-3500**

**Driver/left Side Installation Pictured**

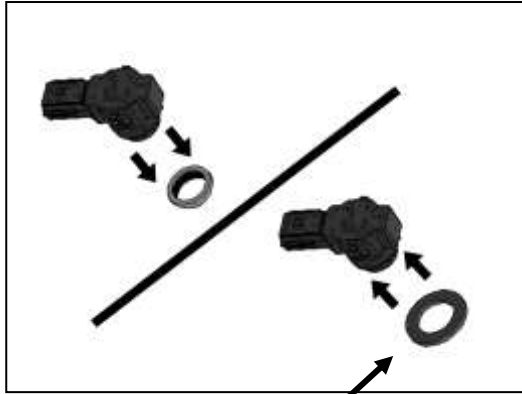

**(Fig 23) Remove silicone seal from sensor. Slide large Seal over end of sensor (arrow)**

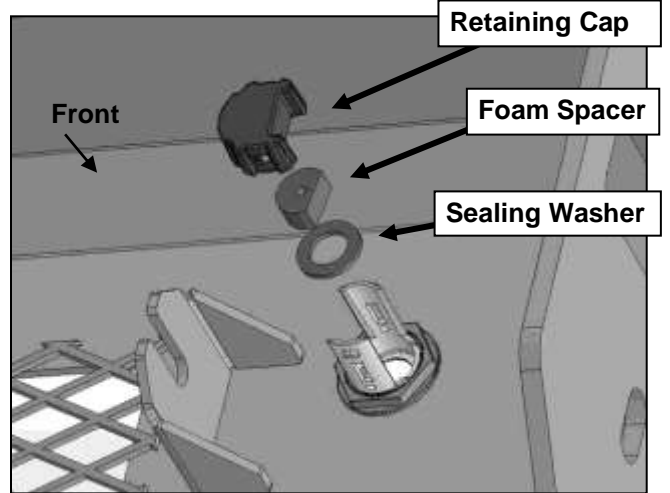

**(Fig 24) Insert sensor into back of Mount. Attach Foam Spacer to back of sensor. Snap Retaining Cap onto end of Mount, over sensor and Spacer**

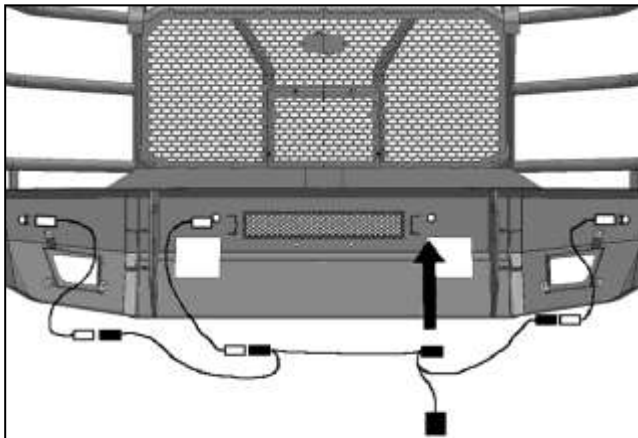

**(Fig 25) Reinstall factory wiring harness over Bumper Brackets on back of Bumper. NOTE: Use the included (3) Wire Harness Extensions as necessary to reach the parking sensors**

**WARNING!** Do not crawl under bumper unless it is properly supported on blocks or stands or the bumper may fall.

**RECOMMENDED TO REPLACE THE 12MM HEX BOLTS ON AN ANNUAL BASIS**

- (3) 12mm x 50mm Hex Bolts
- (6) 12mm Flat Washers
- (3) 12mm Nylon Lock Nuts

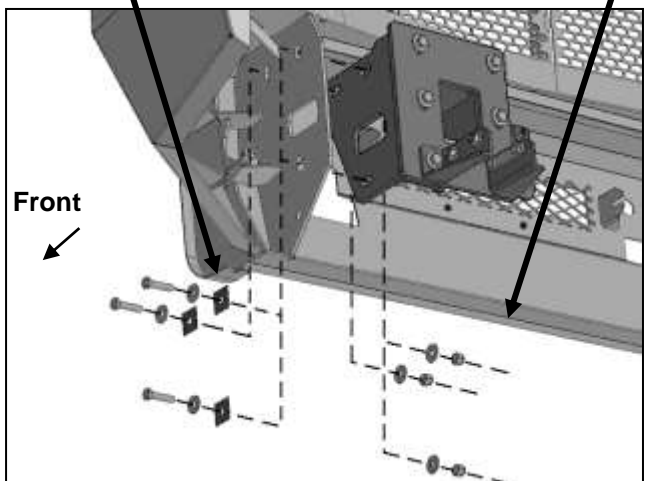

**(Fig 26) Attach Bumper to side of Bracket. NOTE: Insert Plastic Washers between Flat Washer and mounting plate on Bumper to minimize corrosion**



**ALUMINUM ELEVATION FRONT BUMPER  
2020-2022 CHEVY SILVERADO 25-3500**

**Driver/left Side Installation Pictured**

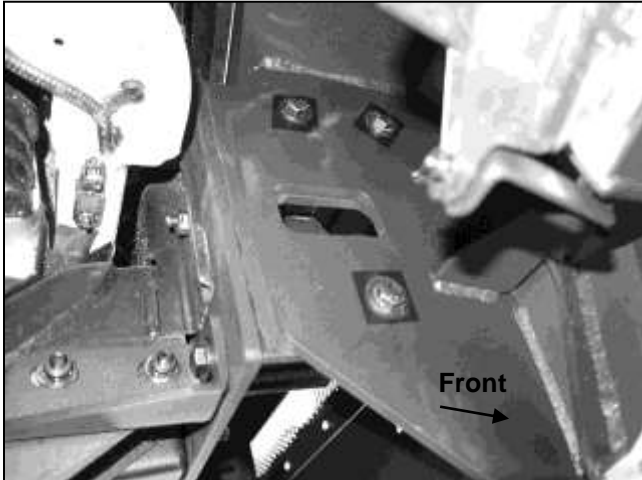

**(Fig 27) Passenger/right side of Bumper installed**

- (2) 12mm x 130mm Hex Bolts
- (4) 12mm Flat Washers
- (2) 12mm Nylon Lock Nuts

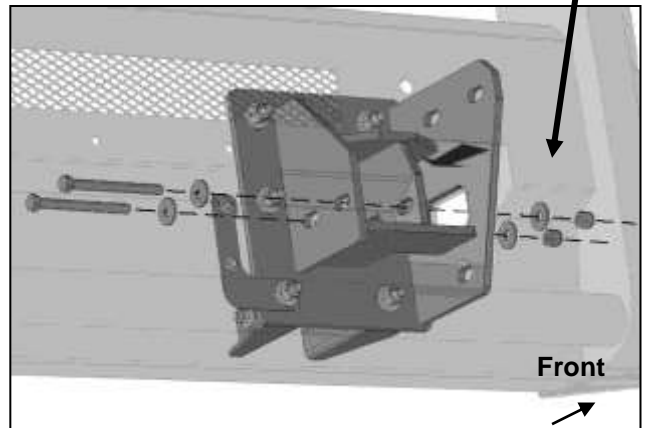

**(Fig 28) Attach tow hook upside-down to inside of Frame Bracket, (if equipped with tow hooks)**

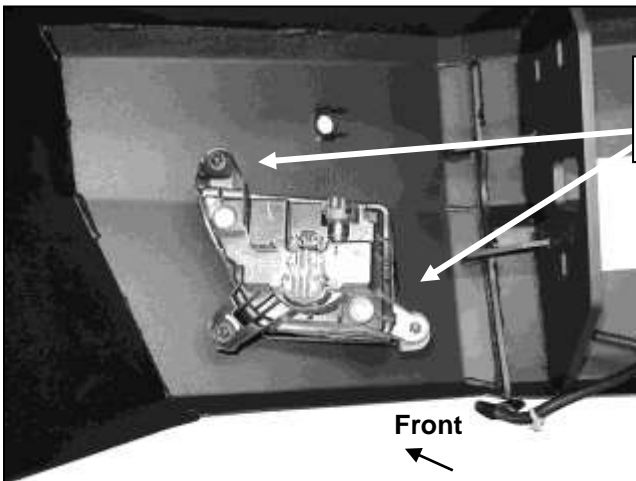

- (3) 6mm x 20mm Hex Bolts
- (6) 6mm Flat Washers
- (3) 6mm Nylon Lock Nuts

**(Fig 29) Attach passenger/right fog light to mounting tabs on driver/left side of Bumper**

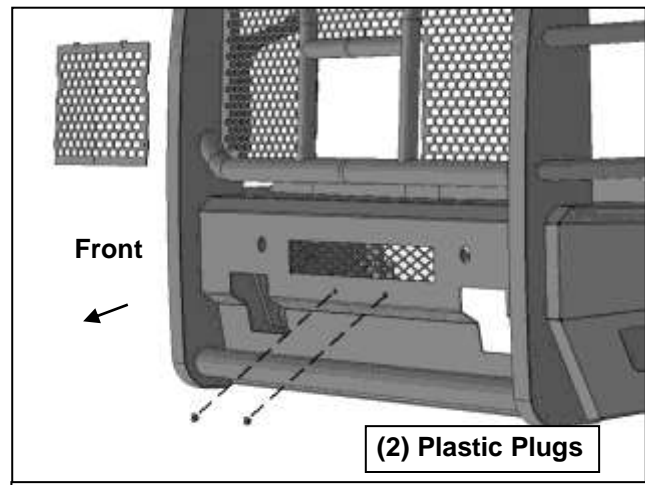

**(Fig 30) Attach License Plate Bracket to Bumper Models with camera, remove screen**



Special Note: While Aluminum does not rust, there is potential for galvanic corrosion if the coating is scratched between your bumper and the steel frame brackets + hardware (especially in extreme environments such as the coastlines or where road salt is used during winter). A visual inspection should be performed by the user at least on an annual basis to determine if excessive corrosion is present on or surrounding the hardware.