



INSTALLATION INSTRUCTIONS

ELEVATION FRONT BUMPER

2015-16 CHEVY SILVERADO 25-3500

PARTS LIST:

1	Front bumper	24	12mm x 37mm OD x 3mm Flat Washers
1	Driver/left Mounting Bracket	14	12mm Lock Washers
1	Passenger/right Mounting Bracket	14	12mm Hex Nuts
1	Driver/left Lower Support Bracket	2	Plastic Plugs for License Plate
1	Passenger/right Lower Support Bracket	8	4mm x 10mm Button Head Screws
4	12mm x 40mm Bolt Plate	1	Wrench
10	12-1.75mm x 50mm Hex Bolts	4	Rubber Sensor Hole Block Offs

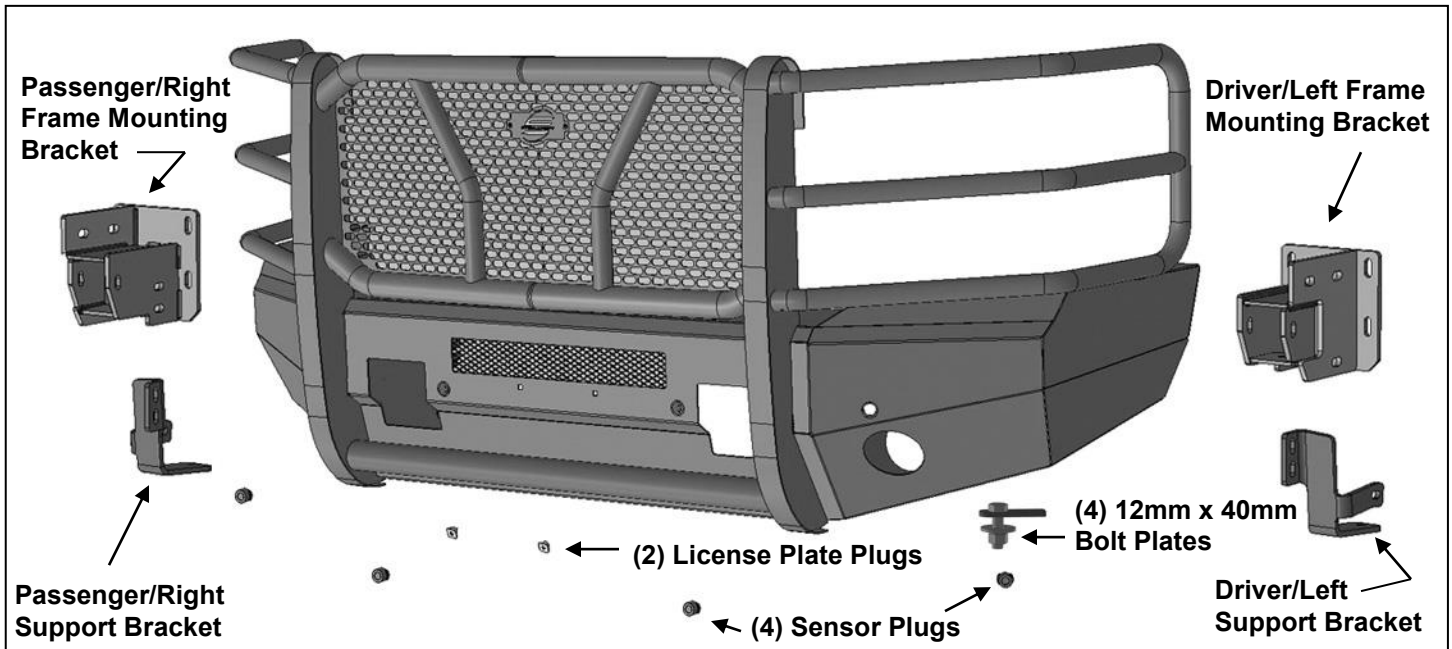

PROCEDURE:

REMOVE CONTENTS FROM BOX. VERIFY ALL PARTS ARE PRESENT. READ INSTRUCTIONS CAREFULLY BEFORE STARTING INSTALLATION. BUMPER IS HEAVY, ASSISTANCE IS HIGHLY RECOMMENDED TO AVOID POSSIBLE INJURY OR DAMAGE TO THE VEHICLE.

1. Open the hood and remove the plastic cover on top of the radiator and the grille, **(Figure 1)**.
2. Remove the license plate and bracket. On models with factory fog lights, unplug both lights. On models with bumper mounted sensors, unplug all sensors. Release the wiring harnesses from the clips attached to the back of the bumper and move all wiring harnesses away from bumper.
3. Release the rubber air deflector from the back of the bumper, if equipped, and remove it from vehicle. Next, remove the hardware at each end of the bumper attaching the bumper supports to each side of the frame, **(Figure 2)**.
4. Place blocks or jack stands under the front bumper to support it during mounting bolt removal. Once the bumper has been safely supported, from above the bumper, remove the (2) factory bumper bolts from each side, **(Figure 3)**. **WARNING!** Assistance is required to hold the bumper in place during bolt removal to prevent the bumper from falling. Remove the bumper assembly.
5. Remove the factory bumper brackets from the ends of frame and remove both tow hooks, **(Figure 4)**.
6. Select (2) 12mm Bolt Plates. Insert Bolt Plates into the inside of the frame and out the bottom and side of the frame, **(Figure 5)**. Select the driver side Support Bracket. Attach the Bracket to the outside of the frame with the included (2) 12mm Flat Washers, (2) 12mm Lock Washers and (2) 12mm Hex Nuts, **(Figures 6 & 7)**. Leave hardware loose at this time.

7. Next, slide the driver side Frame Mounting Bracket down and into position between the Support Bracket and the end of the frame. Attach the inner side of the frame Bracket to the (2) slots in the Support Bracket with (2) 12mm x 50mm Hex Bolts, (4) 12mm Flat Washers, (2) 12mm Lock Washers and (2) 12mm Hex Nuts, **(Figure 8)**. Snug but do not fully tighten hardware at this time.
8. Attach the Frame Bracket to the end of the frame with the (4) factory bumper bracket bolts, **(Figure 9)**. Snug but do not fully tighten the factory hex bolts at this time. **NOTE:** Bumper height will be adjusted with the factory bumper bracket bolts.
9. Select (1) tow hook. Insert the tow hook into the opening in the driver side Frame Bracket, **(Figure 9)**. Insert the long factory tow hook bolt through the outside of the Bracket, the tow hook and the inner plate on the Bracket. Secure with the factory hex nut. **IMPORTANT:** The long hex bolt and must be inserted from the outside of the Bracket to the inside to clear the mounting plate on the Bumper. Reuse the short factory tow hook hex bolt to attach the tow hook to the bottom plate on the Bracket, **(Figures 9 & 10)**. Fully tighten the tow hook hardware only at this time.
10. Repeat **Steps 5—9** to install the passenger side Brackets and tow hook.
11. With assistance, position the Bumper Assembly up to and over the Brackets. Temporarily support the weight of the Bumper. **WARNING:** To avoid possible injury or damage to the vehicle, do not proceed until the Bumper is fully and safely supported.
12. Line up the (3) holes in the driver side mounting plate on the inside of the Bumper with the (3) slots in the Frame Bracket. Attach the Bumper to the Bracket with the included (3) 12mm x 50mm Hex Bolts, (6) 12mm Flat Washers, (3) 12mm Lock Washers and (3) 12mm Hex Nuts, **(Figures 10 & 11)**. Do not fully tighten hardware at this time. Repeat this Step to attach the passenger side mounting plate to the Frame Bracket.
13. Level and adjust the bumper and fully tighten all 12mm hardware to 65-70ft-lbs.
14. **Models with fog lights and/or bumper sensors:**
 - a. Slide the driver side fog light into place through the opening in the bumper, **(Figure 12)**. Carefully push the attaching posts into the tabs on the bumper, **(Figure 13)**. Repeat this **Step** to install passenger side light.
 - b. On models with bumper mounted sensors, remove the rubber plugs from the sockets in the bumper assembly. Push the sensor in from the back of the bumper. Secure each sensor to the socket with (2) 4mm x 10mm Button Head Screws, **(Figure 14)**. **IMPORTANT:** Sensors fit snug in sockets. The 4mm Screws are used to apply slight pressure to lock the sensors in place. Tighten both screws evenly until they touch the sensor body only. Do not overtighten screws or damage to sensors will result.
 - c. Reattach the factory wiring harness to both lights and/or sensors.
15. Use the included (2) push-in Plastic Nuts to attach the front license plate, (if required), to the (2) holes in the front Bumper, **(Figure 15)**.
16. Back of Bumper is equipped with mounting tabs for LED center light. Follow manufacturers installation and wiring instructions for proper installation.
17. Do periodic inspections to the installation to make sure that all hardware is secure and tight.

To protect your investment, wax this product after installing. Regular waxing is recommended to add a protective layer over the finish. Do not use any type of polish or wax that may contain abrasives that could damage the finish. Mild soap may be used to clean the Heavy Duty Front Bumper assembly.

Driver Side Installation Pictured

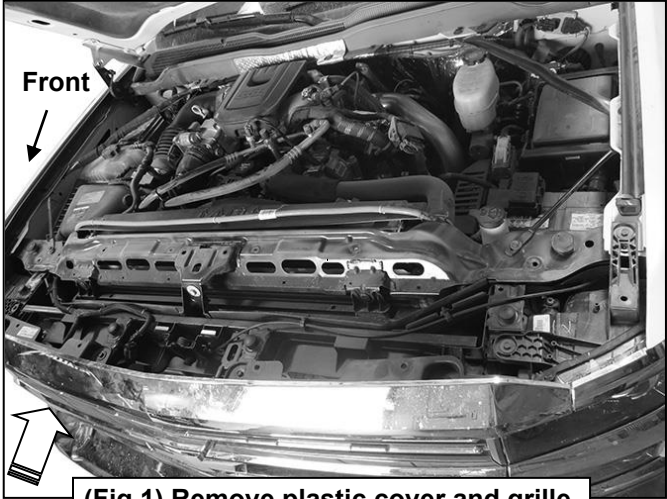

(Fig 1) Remove plastic cover and grille



(Fig 2) Remove bumper supports attaching outer end of bumper to frame (arrow)

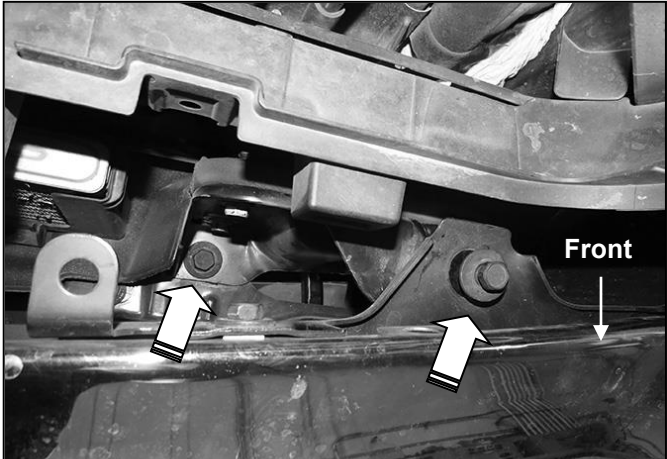

(Fig 3) Remove bumper bolts (arrows) to remove bumper (driver side pictured from above)

WARNING! Do not remove bumper bolts unless the bumper is properly supported on blocks or stands or the bumper may fall.

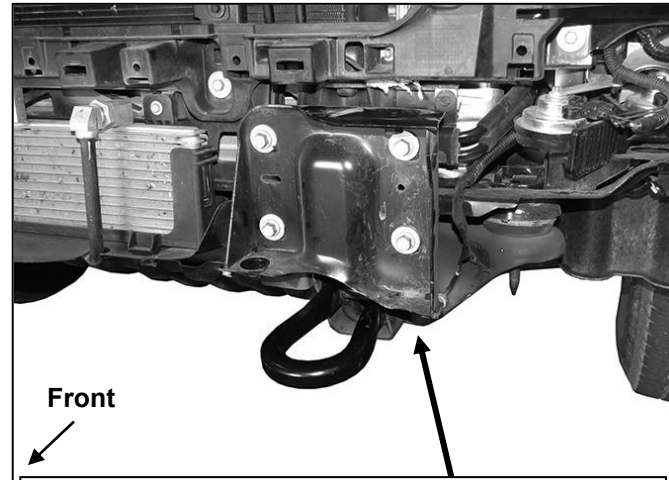

(Fig 4) Remove bumper brackets and tow hooks

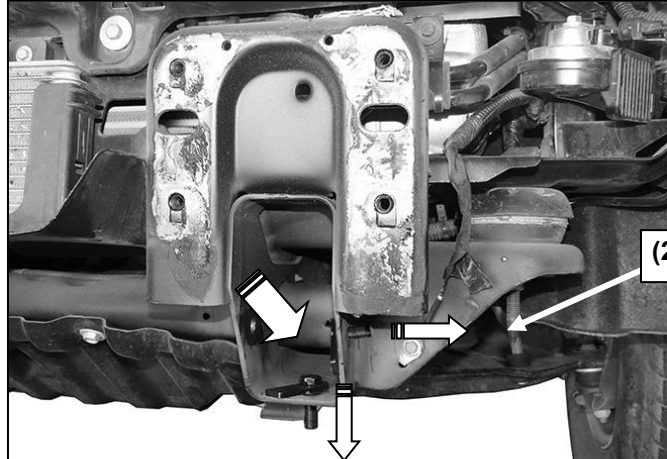

(2) 12mm Bolt Plates

(Fig 5) Insert 12mm Bolt Plates down through hole in bottom and out the side of the frame

WARNING! Do not crawl under bumper unless the bumper is properly supported on blocks or stands or the bumper may fall.

Driver Side Installation Pictured

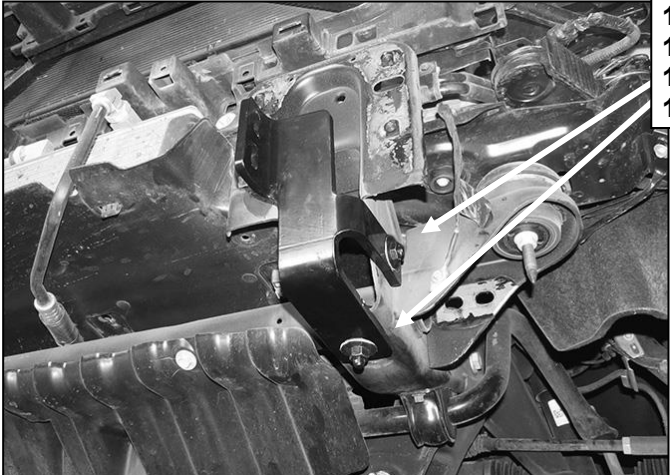

- 12mm Bolt Plate
- 12mm Flat Washer
- 12mm Lock Washer
- 12mm Hex Nut

(Fig 6) Attach driver side Support Bracket to frame

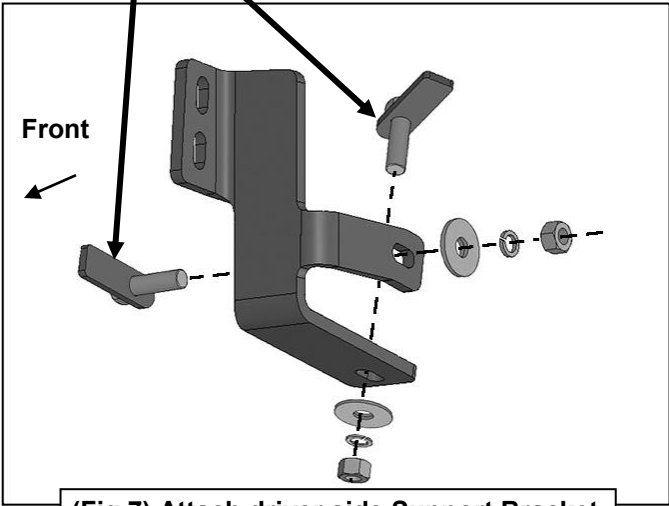

(Fig 7) Attach driver side Support Bracket

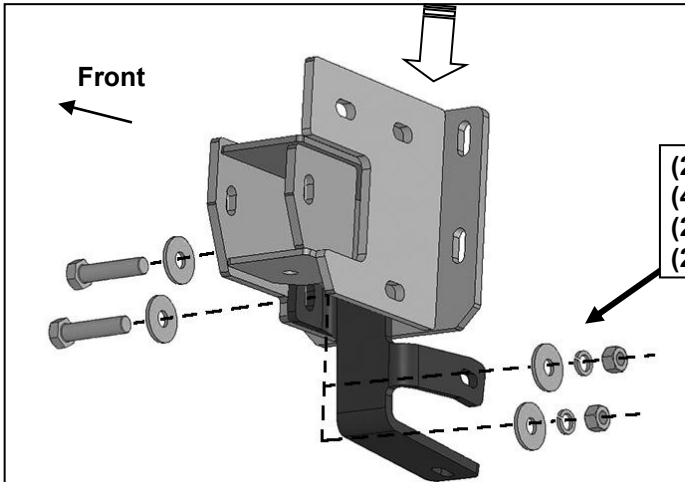

(Fig 8) Slide Mounting Bracket down between Support Bracket and mounting plate on end of frame

- (2) 12mm x 50mm Hex Bolts
- (4) 12mm Flat Washers
- (2) 12mm Lock Washers
- (2) 12mm Hex Nuts

Reuse factory bumper bolts

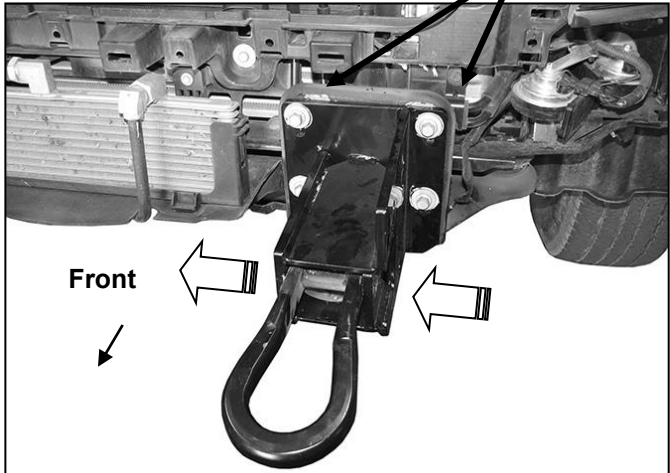

(Fig 9) Reuse factory bumper bolts to attach Mounting Bracket to end of frame. Reuse factory tow hook hardware to attach tow hook to inside of Bracket. **IMPORTANT:** Insert long tow hook bolt from outside to inside only (see arrow)

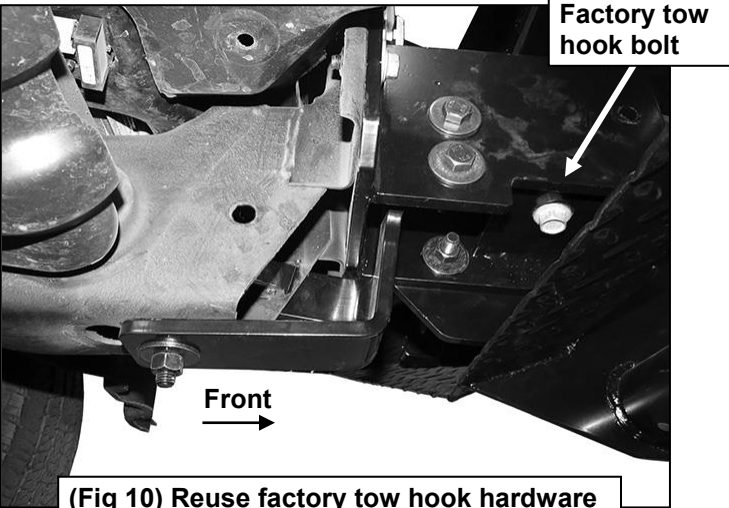

(Fig 10) Reuse factory tow hook hardware to attach tow hook to inside of Bracket

WARNING! Do not crawl under bumper unless the bumper is properly supported on blocks or stands or the bumper may fall.

Driver side installation pictured

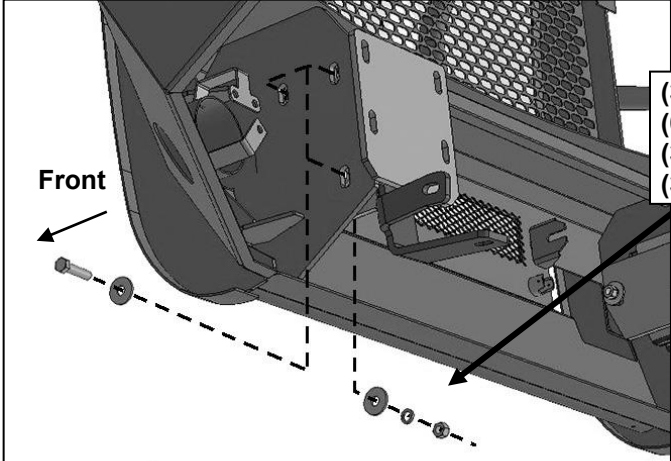

- (3) 12mm x 50mm Hex Bolts
- (6) 12mm Flat Washers
- (3) 12mm Lock Washers
- (3) 12mm Hex Nuts

(Fig 11) Attach Bumper assembly to Frame Brackets



(Fig 12) Factory fog light

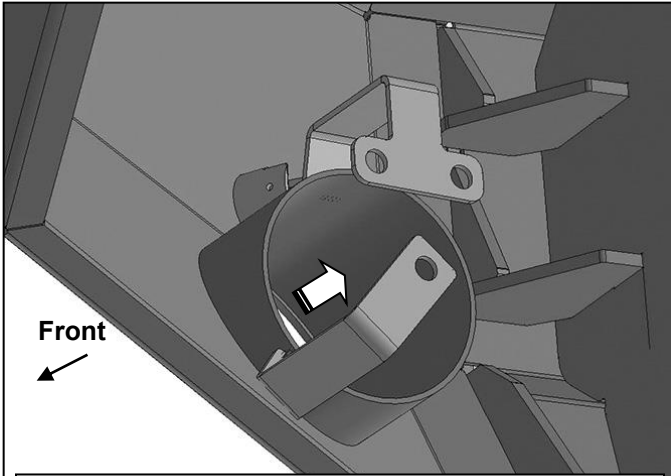

(Fig 13) Attach factory fog light to mounting tabs

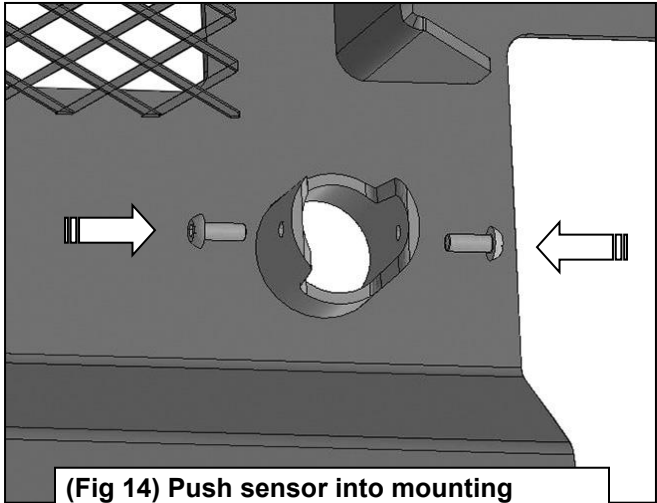

(Fig 14) Push sensor into mounting sleeve. Use 4mm Screws to lock sensor

IMPORTANT: Sensors fit snug in sockets. The 4mm Screws are only used to apply slight pressure to lock the sensors in place. Tighten both screws evenly until they touch the sensor body only. Do not overtighten screws or damage to sensors will result.

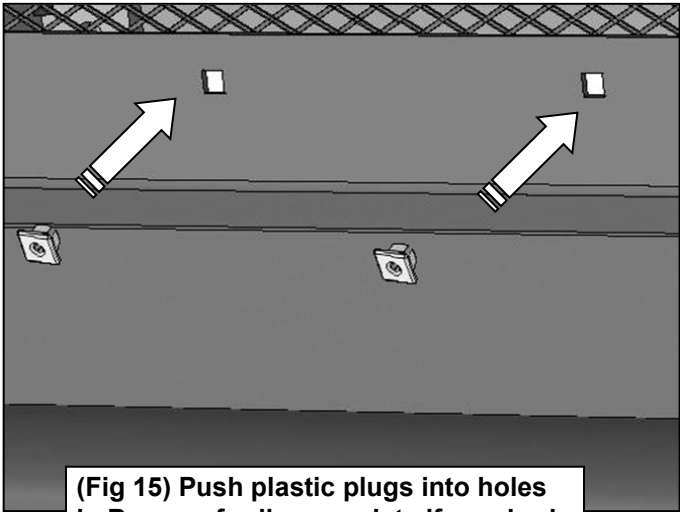

(Fig 15) Push plastic plugs into holes in Bumper for license plate if required