

PARTS LIST:

1	Driver/left T6 Sidebar (76in)	24	8mm x 24mm x 2mm Flat Washers
1	Passenger/right T6 Sidebar (76in)	24	8mm Lock Washers
3	PS Front & DS Center/Rear Mounting Brackets	18	8-1.25mm Hex Nuts
3	DS Front & PS Center/Rear Mounting Brackets	12	6-1.0mm x 25mm Button Head Bolts
6	8mm x 30mm Bolt/Nut Plates	24	6mm x 18mm x 1.6mm Flat Washers
6	8mm x 35mm Double Bolt Plates	12	6-1.0mm Flange Nuts
6	8mm Plastic Retainers	1	Allen Wrench
12	8-1.25mm x 30 Hex Bolts		

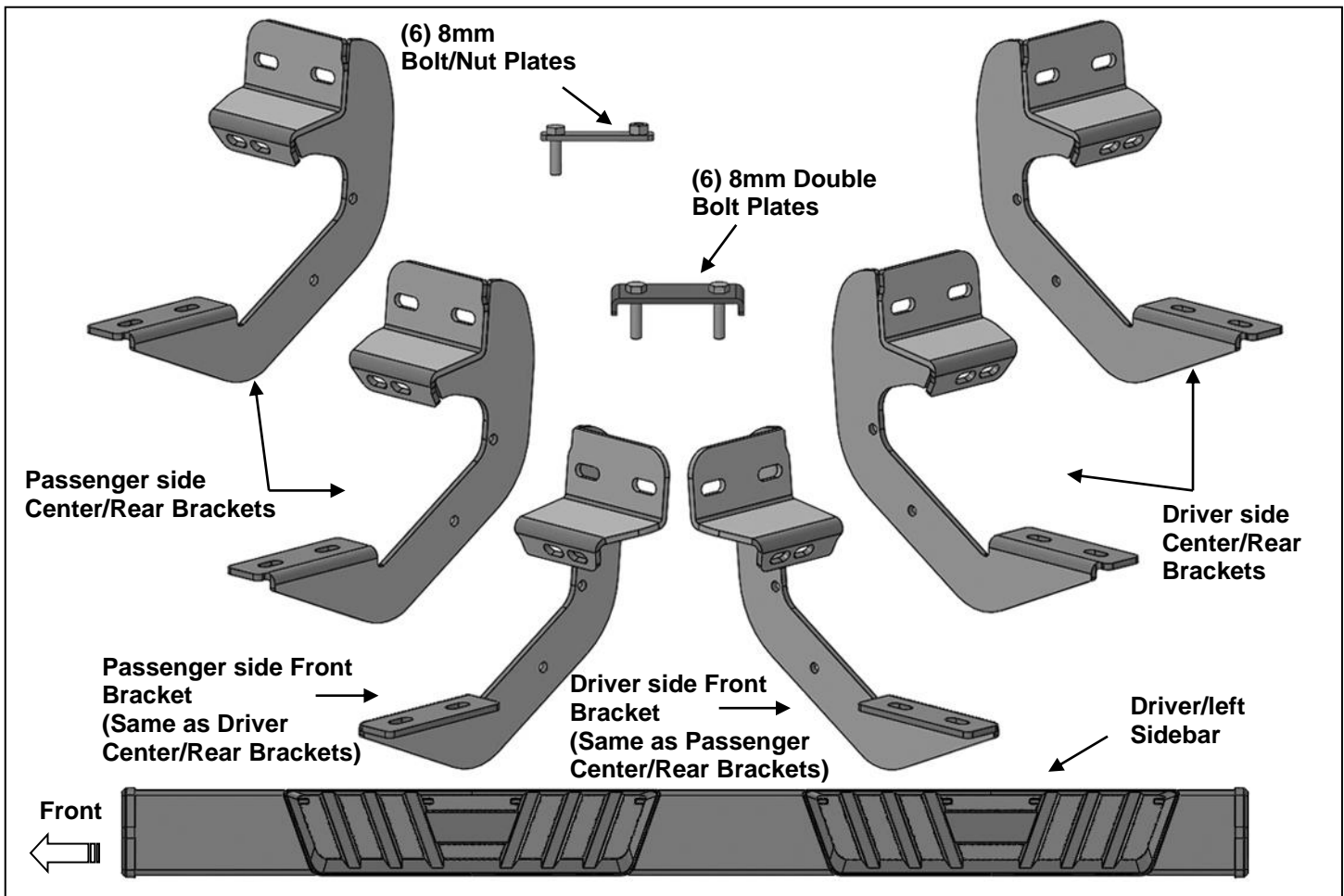

PROCEDURE:

1. REMOVE CONTENTS FROM BOX. VERIFY ALL PARTS ARE PRESENT. READ INSTRUCTIONS CAREFULLY BEFORE STARTING INSTALLATION. DRILLING MAY BE REQUIRED.
2. Starting at the driver front side of the vehicle, remove the sealing tape covering the factory holes in the side of the inner panel, **(Figure 1)**.
3. Determine the correct procedure to attach the Driver Front Bracket for your model/year:

Models without factory threaded inserts in body panel, (see Figure 1):

 - a. Select (1) 8mm Bolt-Nut Plate, **(Figure 2)**. Partially thread an 8mm Hex Bolt into the threaded nut on the Bolt-Nut Plate, **(Figure 3)**. Thread the Hex Bolt in until it is flush with the welded nut. Use the Hex Bolt as a handle and insert the Bolt-Nut Plate into the oval hole, **(Figure 4)**. Feed the threaded bolt on the Bolt-Nut Plate through one of the hex shaped factory holes.
 - b. Thread (1) 8mm Plastic Retainer onto the threaded end and down tight against the body panel, **(Figure 5)**. **NOTE:** The Plastic Retainer is designed to keep the Bolt-Nut Plate from falling into the body panel and to aid in Bracket installation.

- c. Select the driver side Front Bracket, **(Figure 6)**. Attach the Bracket to the threaded end of the Bolt Plate with (1) 8mm Flat Washer, (1) 8mm Lock Washer and (1) 8mm Hex Nut, **(Figure 6)**.
- d. Remove the 8mm Hex Bolt from the nut on the Bolt Plate from **Step 3a**. Rotate the Bolt on the Bolt-Nut Plate until the threaded nut lines up with the remaining hole in the Bracket and hex hole in the body panel, **(Figure 5)**. Attach the Bracket to the threaded nut with (1) 8mm x 30mm Hex Bolt, (1) 8mm Lock Washer and (1) 8mm Flat Washer, **(Figure 6)**. Do not tighten hardware.

Models with factory threaded inserts, (see Figure 7):

- a. Attach the driver side Front Bracket to the threaded inserts with (2) 8mm x 30mm Hex Bolts, (2) 8mm Lock Washers and (2) 8mm Flat Washers, **(Figure 8)**. Leave hardware loose.
4. Next, attach the Bracket to the back of the pinch weld with (2) 6mm Button Head Bolts, (4) 6mm Flat Washers and (2) 6mm Flange Nuts, **(Figure 9)**. Do not fully tighten hardware at this time.
IMPORTANT: Most 2009-12 models are not equipped with factory holes and will require drilling through the pinch weld to attach the Bracket. Do not drill through pinch weld at this time, **(see Step 9)**.
5. Move along the side of the body panel to the center mounting location, **(Figure 10)**. Repeat the appropriate **Steps 2—4** to install the driver side Center Bracket.
6. Move to the rear location, **(Figure 11)**. Repeat the appropriate **Steps 2—4** to install the Driver side Rear Bracket.
7. Carefully unwrap and select the driver/left T6 Sidebar. Use the illustration above to help identify the correct Sidebar. Place the Sidebar on top of the Brackets. **IMPORTANT:** Do not slide, (front to back), the Sidebar on the Brackets or damage to the finish may result. Locate the channel opening in the bottom of the Sidebar. Select (3) 8mm Double Bolt Plates, **(Figure 12)**. Insert the Bolt Plates into the channel in the bottom of the Sidebar closest to the Brackets, **(Figure 13)**. Lift the Sidebar up and guide the studs through the Brackets.
8. Attach the Sidebar to the Brackets with (6) 8mm Flat Washers, (6) 8mm Lock Washers and (6) 8mm Hex Nuts, **(Figure 14)**. Do not tighten hardware at this time.
9. Properly level and adjust the Sidebar and fully tighten all hardware.
2009-12 models requiring drilling to attach Brackets to pinch weld:
 - a. Level the Sidebar to the vehicle. Make sure all (3) Brackets are tight against the bottom of the body panel and tighten all mounting hardware.
 - b. Mark the location of the slots onto the pinch weld.
 - c. Temporarily remove the Sidebar and the (3) Mounting Brackets. Drill (2) 1/4" holes through the pinch weld for each Bracket. **IMPORTANT:** Do not drill too close to the bottom edge of the pinch weld. Drill the holes in the center of the marked slots.
 - d. Repeat **Step 4** to attach the Brackets to the drilled holes in the pinch weld. Check for level then fully tighten all hardware.
10. Repeat **Steps 2—9** for Passenger/right Sidebar installation.
11. Do periodic inspections to the installation to make sure that all hardware is secure and tight.

To protect your investment, wax this product after installing. Regular waxing is recommended to add a protective layer over the finish. Do not use any type of polish or wax that may contain abrasives that could damage the finish. Mild soap may be used to clean the Sidebars.

Driver/left Side Installation Pictured

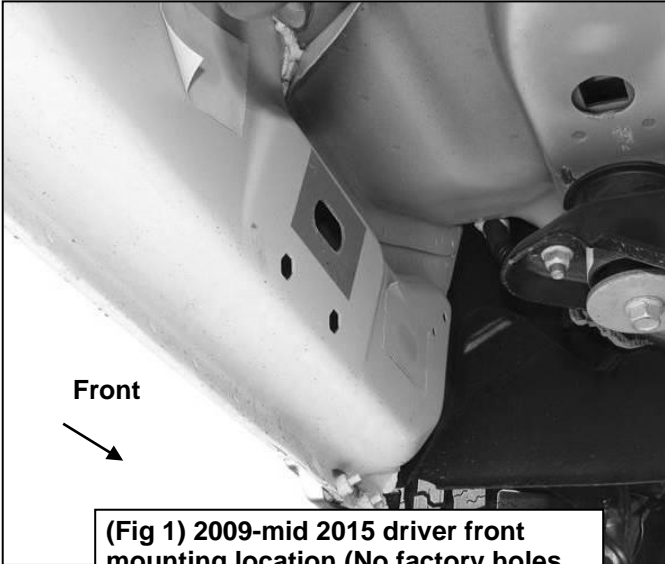

(Fig 1) 2009-mid 2015 driver front mounting location (No factory holes in pinch weld 2009-2012 models)

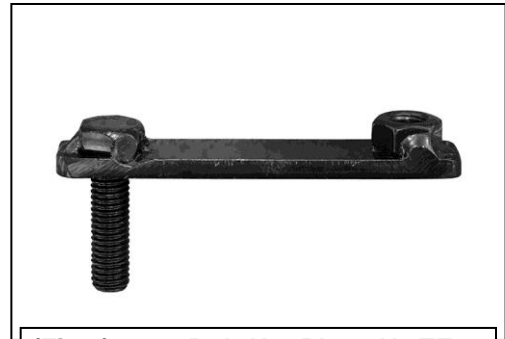

(Fig 2) 8mm Bolt-Nut Plate, NOTE: 8mm Bolt-Nut Plate is not required on models with threaded inserts

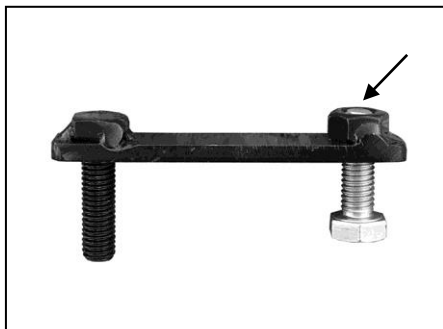

(Fig 3) Thread (1) 8mm Hex Bolt into the nut on the plate. Stop when bolt reaches end of nut as pictured

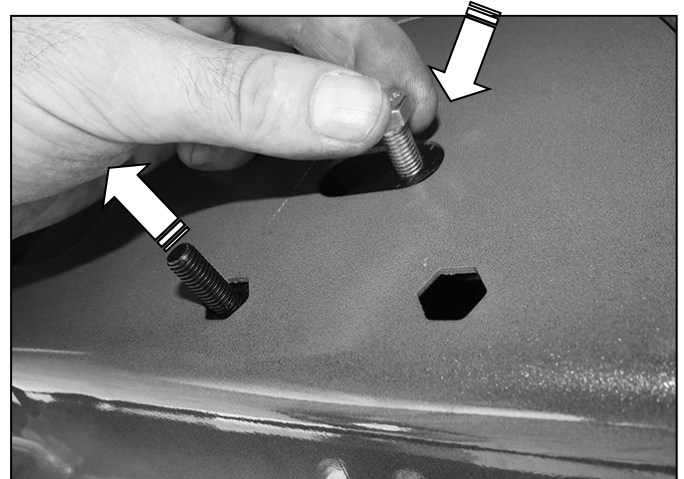

(Fig 4) Use the loose Hex Bolt as a handle. Insert the Bolt Plate into the oval hole and feed the threaded end out either factory hex shaped hole. IMPORTANT: Do not let go of the hex bolt until after Plastic Retainer has been threaded onto bolt (Fig 5)

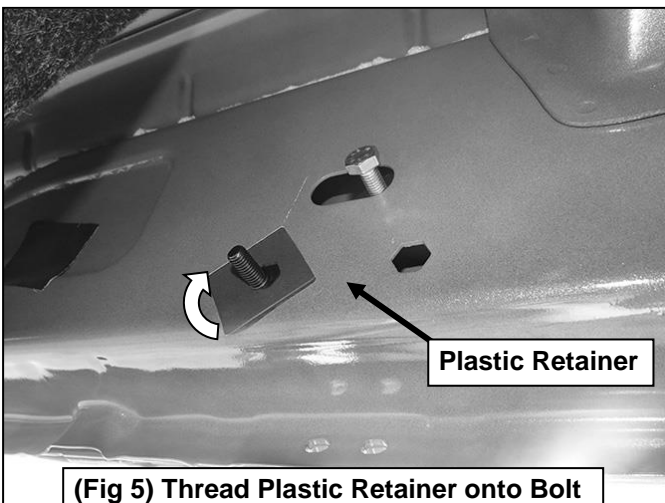

(Fig 5) Thread Plastic Retainer onto Bolt Plate to hold Bolt Plate in position.

Driver/left Side Installation Pictured

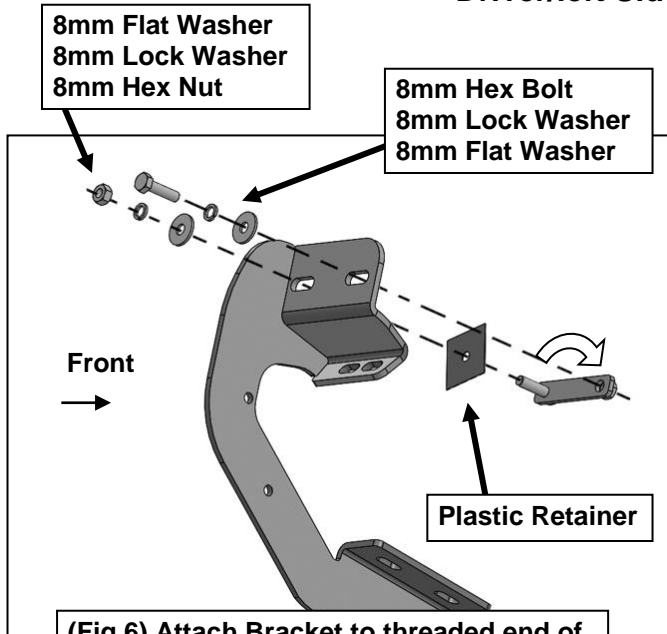

(Fig 6) Attach Bracket to threaded end of Bolt Plate first. Remove 8mm Hex Bolt (see Fig 3). Rotate Bolt Plate to line up with remaining factory hex shaped hole.

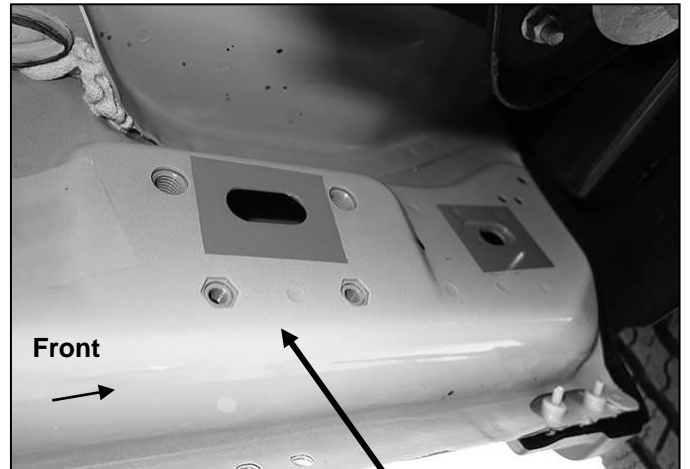

(Fig 7) Driver side front mid 2015-on (example of models with factory installed threaded inserts)

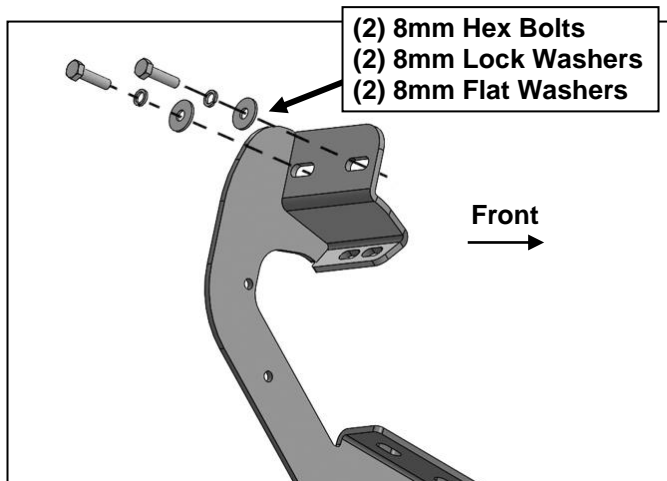

(Fig 8) Driver side front models with factory installed threaded inserts. Bolt Plate not required

IMPORTANT: 2009-2012 models without holes in pinch weld will require drilling 1/4" holes through pinch weld to attach the bracket. Do complete installation of Sidebars first, level Sidebar before drilling holes for bracket.

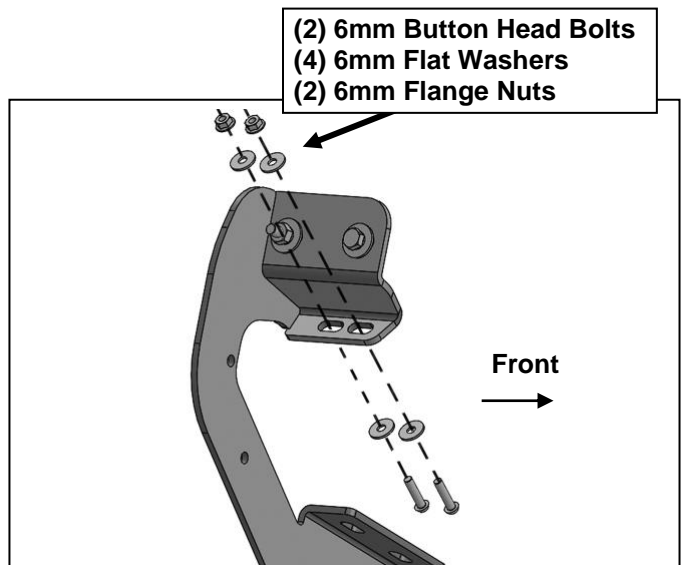

(Fig 9) Attach Bracket to back of pinch weld (models with factory holes in pinch weld only)

Driver/left Side Installation Pictured

IMPORTANT: 2009-2012 models without holes in pinch weld will require drilling 1/4" holes through pinch weld to attach the bracket. Do complete installation of Sidebars first, level Sidebar before drilling holes for bracket.

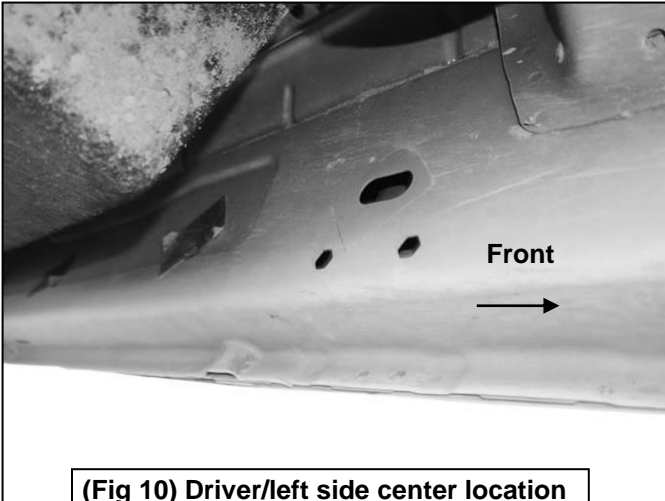

(Fig 10) Driver/left side center location

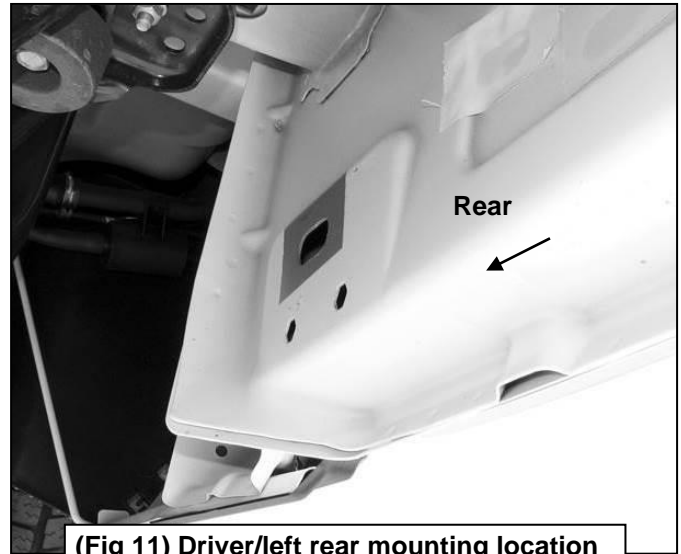

(Fig 11) Driver/left rear mounting location

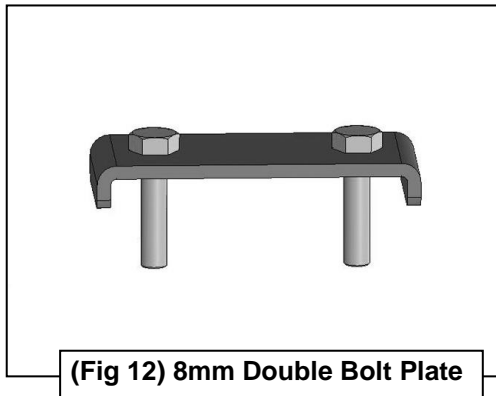

(Fig 12) 8mm Double Bolt Plate

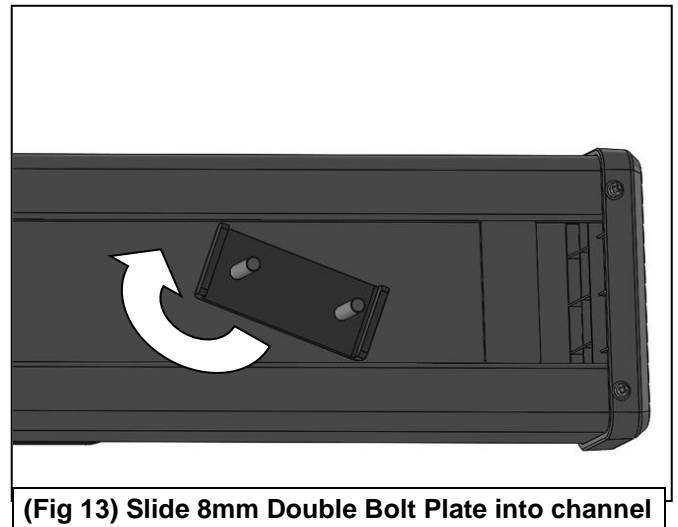

(Fig 13) Slide 8mm Double Bolt Plate into channel

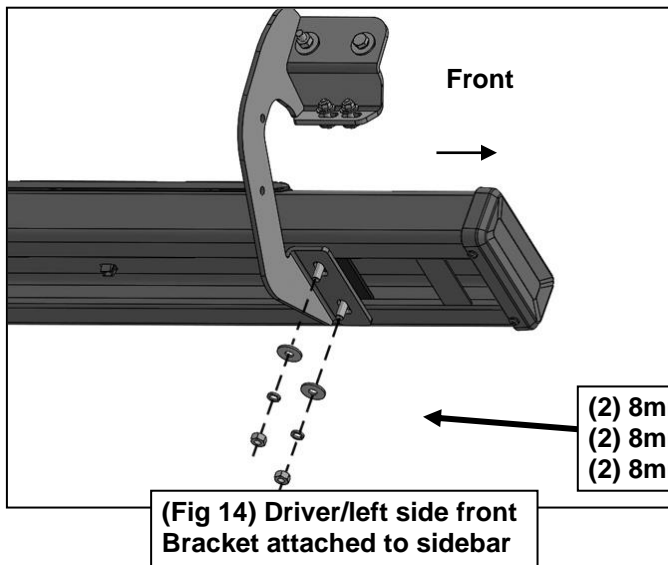

(Fig 14) Driver/left side front Bracket attached to sidebar

- (2) 8mm Flat Washers
- (2) 8mm Lock Washers
- (2) 8mm Hex Nuts