

**PARTS LIST:**

2	T-6 Side Bars	8	8mm Double Bolt Plates
1	Passenger/right Front Upper Bracket (all incl. DEF)	17	8-1.25mm x 25mm Hex Bolts
1	Passenger/right Front Lower Bracket (all incl. DEF)	33	8mm x 24mm x 2mm Flat Washers
7	Sidebar Brackets (use for left or right)	33	8mm Lock Washers
15	8mm U-Clip Nuts	17	8mm Hex Nuts
1	8mm Bolt Plate		

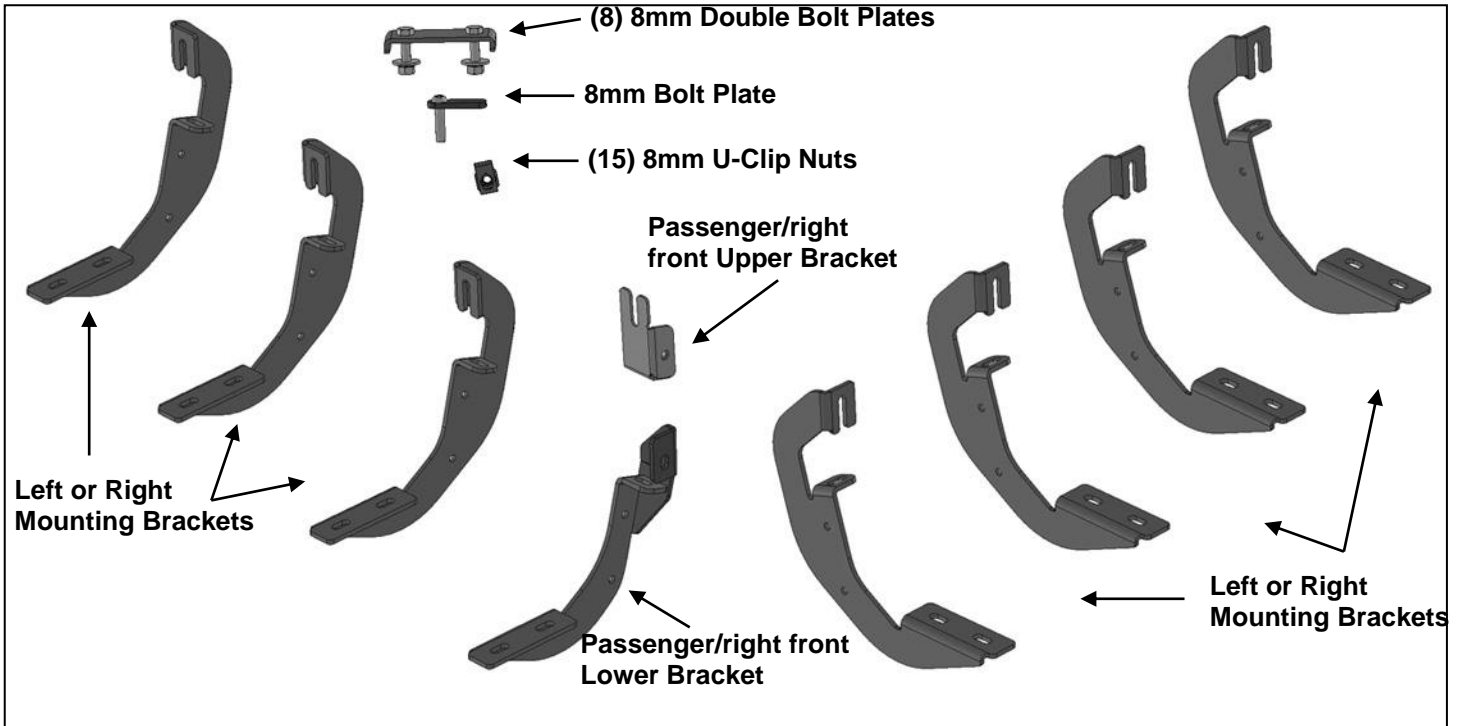

**PROCEDURE:**

**REMOVE CONTENTS FROM BOX. VERIFY ALL PARTS ARE PRESENT. READ INSTRUCTIONS CAREFULLY BEFORE STARTING INSTALLATION. ASSISTANCE IS RECOMMENDED. ON MODELS WITH DEF TANK, SELECT A FLAT, LEVEL AREA FOR INSTALLATION. MAY REQUIRE CUTTING.**

1. Start the installation under the driver side of the vehicle. Locate the 5 tabs along the bottom edge of the body, (pinch weld). Mounting Brackets will attach to the 1st, 2nd, (just in front of center of cab), 4th and 5th mounting tabs, **(Figure 1)**. Directly above each tab is a top mounting location on the side of the body panel. Hold a Bracket up in place to help determine the mounting holes to use along the body.
2. Determine the correct procedure for your model year and each Bracket location.

**Bottom mounting location on the edge of the pinch weld.**

**Flat tab on pinch weld with factory installed weld nut:**

Thread hex bolt into weld nut from the backside-down to clear paint from threads, **(Figure 2)**.

**Flat tab on pinch weld with hole:**

Select (1) 8mm Clip Nut. Slide the Clip Nut over the tab with the nut facing up behind the tab, **(Figures 3—5)**. Line up threaded nut with hole in tab. Repeat for each mounting location.

**Top mounting location on the side of the body panel.**

**Models with factory installed threaded insert in body panel:**

Thread 8mm Hex Bolt into threaded insert to clear paint as required, **(Figures 2 & 3)**.

**Large and small hole in side of body panel:**

Remove the rubber plug from the larger hole, **(Figure 4)**. Select (1) 8mm Clip Nut. Slide the Clip Nut into the larger hole. Line up the threaded nut with the smaller hole, **(Figure 5)**.

3. Select (1) Mounting Bracket. **NOTE:** (7) Brackets are universal and will fit all left side and (2) center and (1) rear locations only on right side of vehicle. Attach the Bracket to the Clip Nuts and/or the factory

threaded holes with (2) 8mm Hex Bolts, (2) 8mm Lock Washers and (2) 8mm Flat Washers, **(Figures 6—8)**. Snug but do not fully tighten the hardware.

4. Repeat **Steps 1—3** to install the (2) center and (1) rear driver/left side Brackets, **(Figures 6—8)**.
5. Select (1) T-6 Side Bar. Carefully position the Side Bar onto the (4) Mounting Brackets. **IMPORTANT:** Do not slide the Side Bar on the Brackets or damage to the finish may result. Select (4) 8mm Double Bolt Plates. Insert the Bolt Plates into the channels in the bottom of the Side Bar close to the Brackets, **(Figure 9)**. Lift the Side Bar up and guide the studs down through the Brackets.
6. Attach the Side Bar to the Brackets with (8) 8mm Flat Washers, (8) 8mm Lock Washers and (8) 8mm Hex Nuts, **(Figure 10)**. **NOTE:** The Side Bar is designed to fit close to the vehicle. It may be necessary to loosen the Bracket hardware and tilt the Brackets downward to insert the Side Bar between the Brackets and the body. Do not tighten hardware at this time.
7. Level and adjust the Side Bar and fully tighten all hardware.
8. Move to the passenger side of the vehicle. Determine if the vehicle is equipped with a plastic diesel exhaust fluid (DEF) tank, **(Figures 12 & 13)**.

**Models without DEF tank, skip to Step 9.**

**2007-16 Models with DEF tank:** The tank sits close to the side of the body. With specialized tools, the passenger/right front upper and lower Bracket can be installed but room is limited. It may be easier to drop the tank down to access the inner side of the body panel for upper bracket installation. Tank will not need to be removed, only dropped down for access to mounting location. **IMPORTANT:** If tank is full, it will be very heavy, and assistance is highly recommended to avoid injury or damage to the vehicle or the tank. It is recommended that installation is performed when the DEF tank is low on fluid before dropping the tank.

- a. On 07-16 models with plastic lower tray under tank, remove the (3) hex bolts attaching the tray to the frame, **(Figure 11)**, and remove tray.
- b. Release the tank filler hose. Release the plug for the sending unit on the top of the tank.
- c. Support the tank with a floor jack. Place a smooth flat surface, (wooden block for example), between the floor jack and the tank to avoid damaging the plastic tank. Do not push up on the tank; only support the weight of the tank with the jack.
- d. Remove the (2) bolts securing the tank straps to the vehicle, **(Figure 12)**. Tilt the straps to release from the brackets. Slowly lower the tank until the top of the tank is almost visible. Use blocks or stands to support the tank while installing the front Upper and Lower Brackets.
- e. Proceed to **Step 9**.

**2017-on Models with DEF tank:** Remove only the plastic cover from the tank, **do not remove tank**, **(Figures 13 & 14)**.

9. Locate the first tab on the edge of the pinch weld on the passenger side, **(Figures 2—4, 16, 18 & 21)**. Select the Front Upper Bracket, **(Figure 15)**. Repeat **Steps 2 & 3** to attach the Upper Bracket to the side of the body panel, **(Figure 16 & 18)**. Do not tighten hardware at this time.
10. Line up the hole in the bottom of the Upper Bracket with the hole in the tab on the pinch weld.
  - a. **Models with a weld-nut:** Slide the Bracket over the weld-nut, **(Figure 16)**. Attach the Lower Bracket to the bottom of the body and weld-nut with (1) 8mm x 25mm Hex Bolt, (1) 8mm Lock Washer and (1) 8mm Flat Washer, **(Figure 19)**. Leave loose at this time.
  - b. **Models with flat tab and hole:** Insert the 8mm Bolt Plate down through the hole in the Upper Bracket and mounting tab, **(Figure 17)**. Attach the Lower Bracket to the bottom of the body and Bolt Plate with (1) 8mm Flat Washer, (1) 8mm Lock Washer and (1) 8mm Hex Nut, **(Figures 18 & 19)**. Leave loose at this time.
11. Attach the Lower Bracket to the front facing side of the Upper Bracket with (1) 8mm x 25mm Hex Bolt, (1) 8mm Lock Washer and (1) 8mm Flat Washer, **(Figures 19 & 20)**. Leave loose at this time.
12. Move to the 2nd mounting location, **(Figure 21)**. Repeat **Steps 1—3** for the (3) remaining passenger/right Bracket installations. **NOTE:** Cradles on Brackets installed on passenger side will face forward.
13. Repeat **Steps 5—7** to install the passenger/right Side Bar, **(Figure 22)**.
14. Once the Side Bars are installed, lined up to side of vehicle and all hardware fully tightened, reinstall the DEF tank and cover, if equipped, as described in **Step 8**.

- a. **2017-on 2500-3500 DEF tank models only:** Hold the DEF cover up in place and mark the 2nd Bracket location onto the cover, **(Figures 21 & 23)**. Use a sharp knife or hacksaw blade to carefully cut a slot in the plastic cover to clear the 2nd Bracket, **(Figure 24)**.

15. Do periodic inspections to the installation to make sure that all hardware is secure and tight.

**To protect your investment,** wax this product after installing. Regular waxing is recommended to add a protective layer over the finish. Do not use any type of polish or wax that may contain abrasives that could damage the finish.

**For stainless steel:** Aluminum polish may be used to polish small scratches and scuffs on the finish. Mild soap may be used also to clean the Side Bar.

**For gloss black finishes:** Mild soap may be used to clean the Side Bar.

### Driver/Left Side Installation Pictured

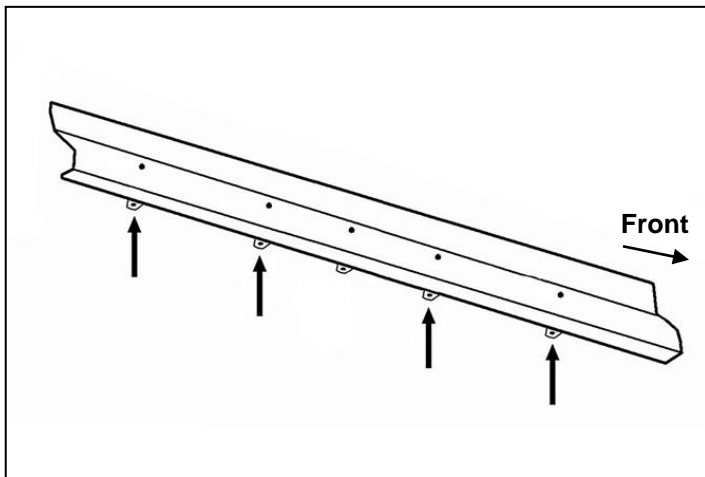

(Fig 1) Back of driver side (4) mounting locations

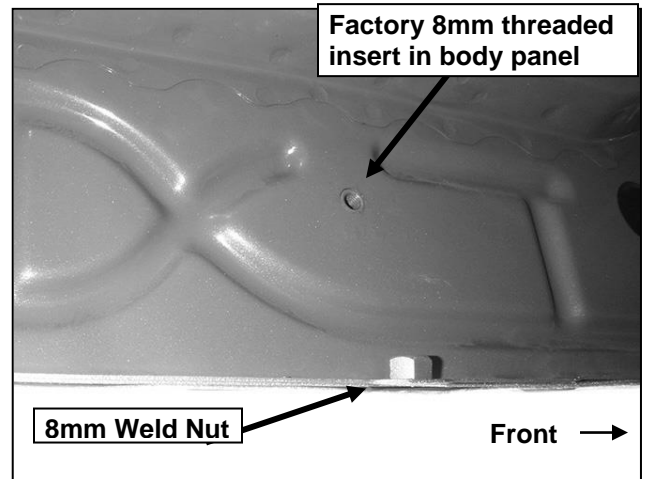

(Fig 2) Driver side front mounting location

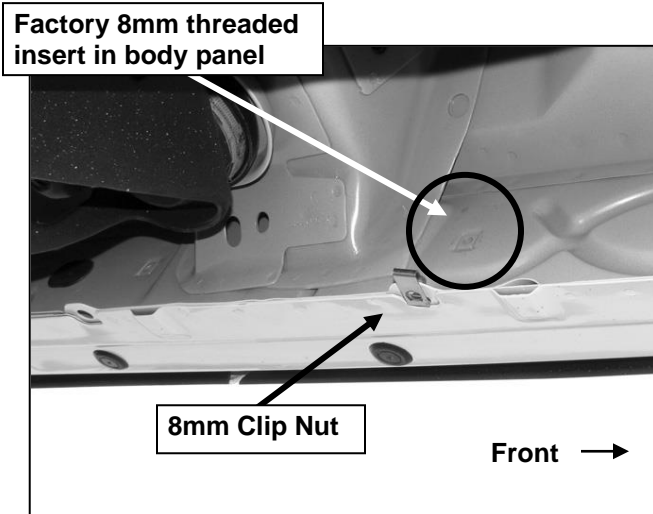

(Fig 3) Driver side 2nd mounting location

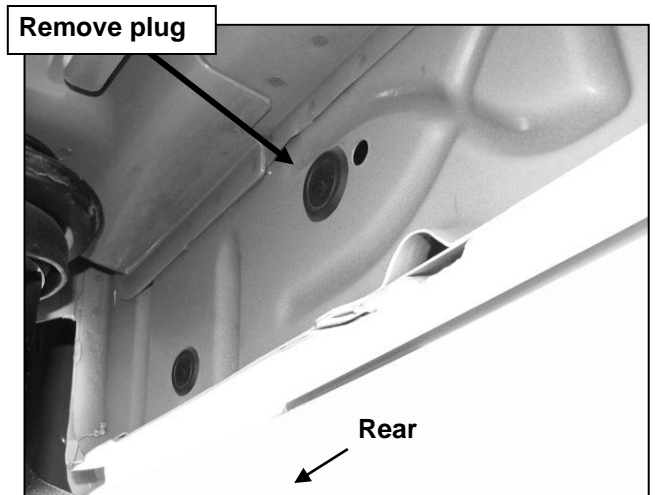

(Fig 4) Driver side rear mounting location

**Driver/Left Side Installation Pictured**

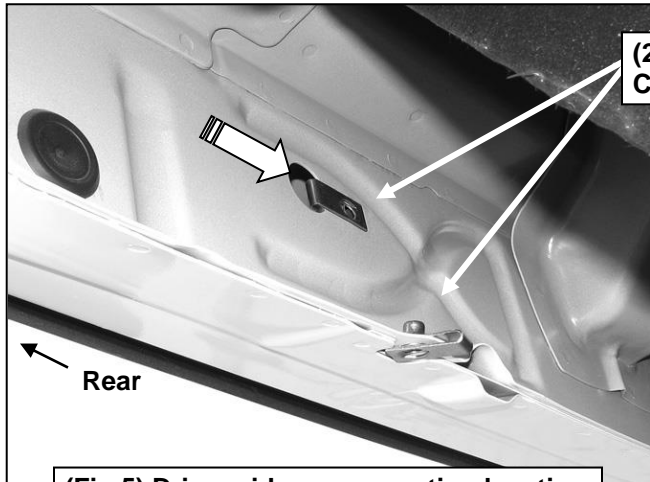

**(Fig 5) Driver side rear mounting location**

**(2) 8mm  
Clip Nuts**

**(2) 8mm x 25mm Hex Bolts  
(2) 8mm Lock Washers  
(2) 8mm Flat Washers**

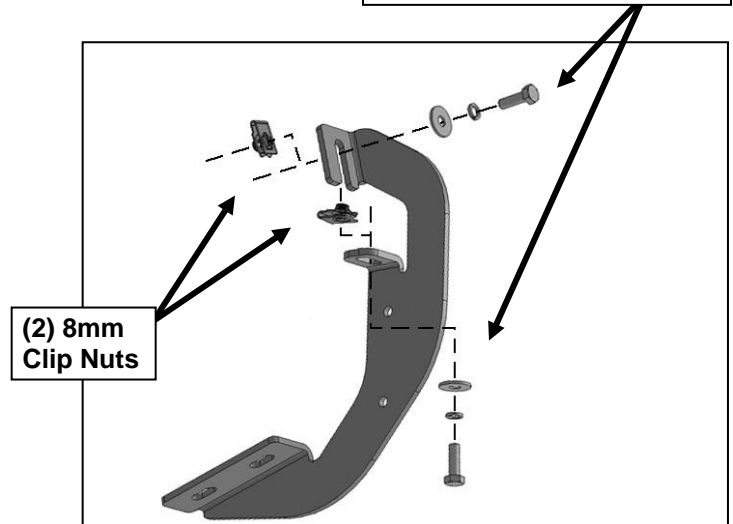

**(2) 8mm  
Clip Nuts**

**(Fig 6) Example of bracket installation**

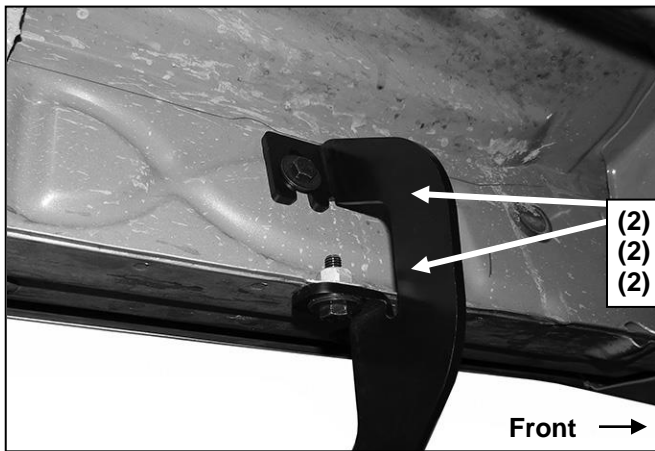

**(2) 8mm x 25mm Hex Bolts  
(2) 8mm Lock Washers  
(2) 8mm Flat Washers**

**(Fig 7) Example driver/left front bracket installed.  
NOTE: factory threaded weld nuts in body panel**

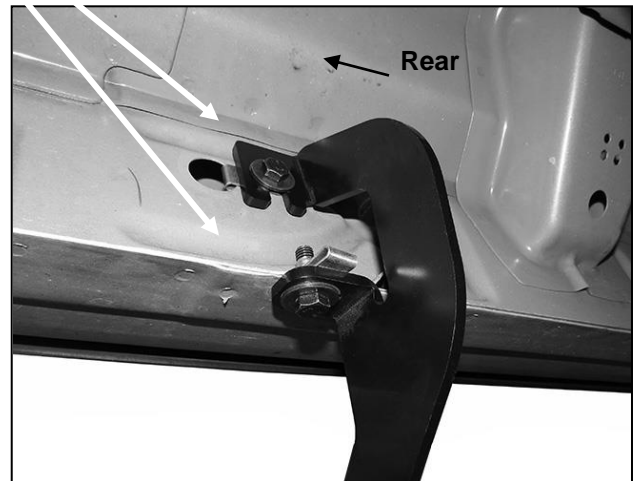

**(Fig 8) Example driver/left rear  
bracket installed. NOTE: 8mm Clip  
Nuts used to attach to body panel**

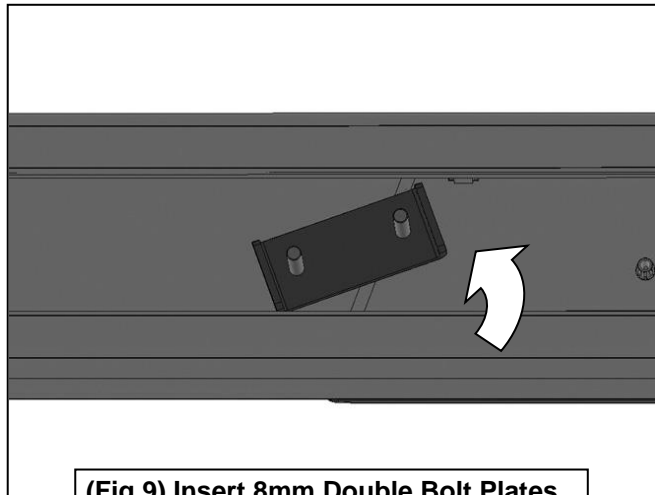

**(Fig 9) Insert 8mm Double Bolt Plates  
into tracks on bottom of Sidebar**

### Passenger/right Side Installation Pictured

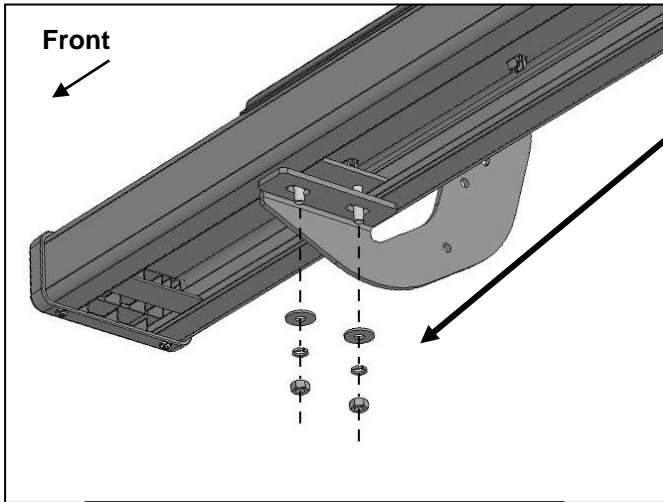

(Fig 10) Attach Sidebar to Brackets

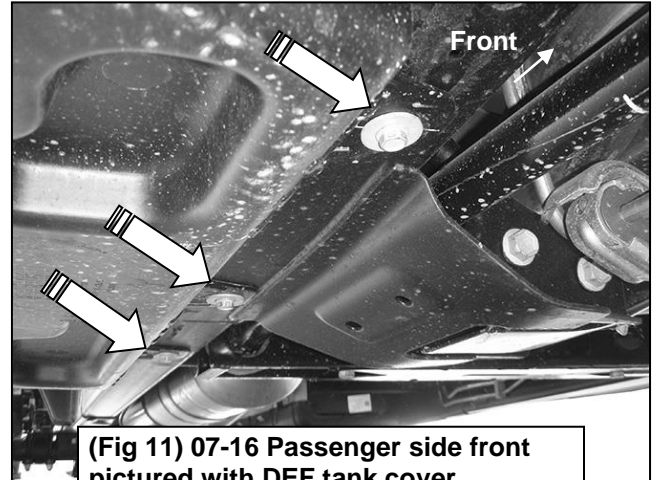

Remove (2) factory bolts to remove tank straps

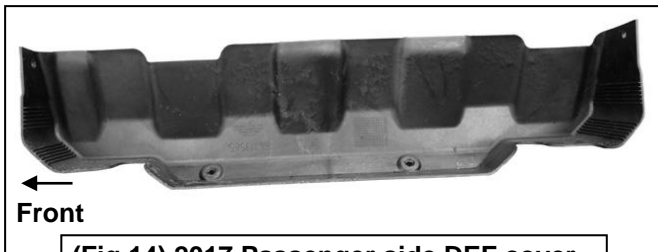
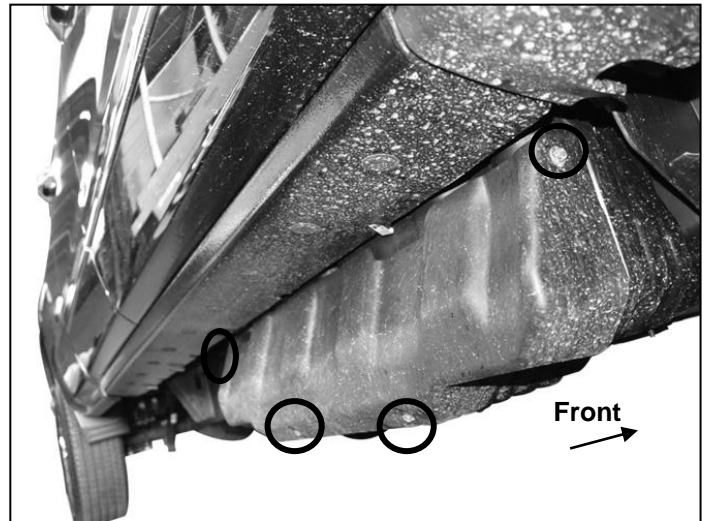
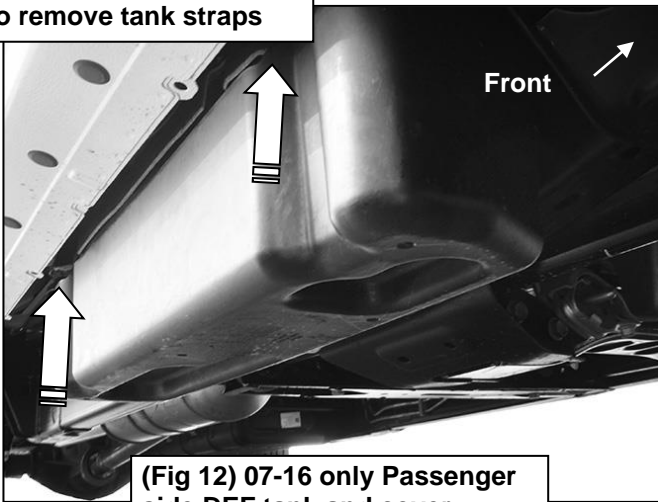

### Passenger/right Side Installation Pictured

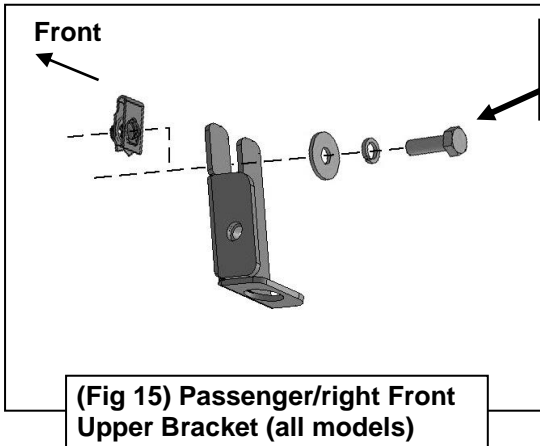

8mm x 25mm Hex Bolt  
8mm Lock Washer  
8mm Flat Washer

Models with weld nut on tab use:  
8mm x 25mm Hex Bolt  
8mm Lock Washer  
8mm Flat Washer  
to bolt Lower Bracket to weld nut

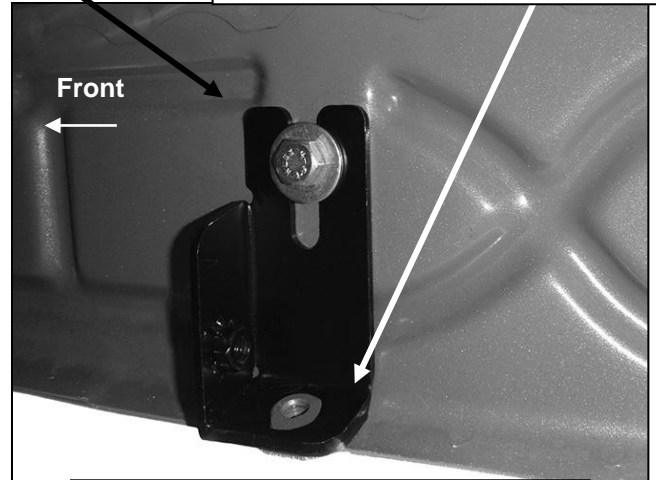

On models with flat tab (see Fig 3 and 4),  
insert 8mm Bolt Plate (Fig 16) down  
through Upper Bracket and mounting tab

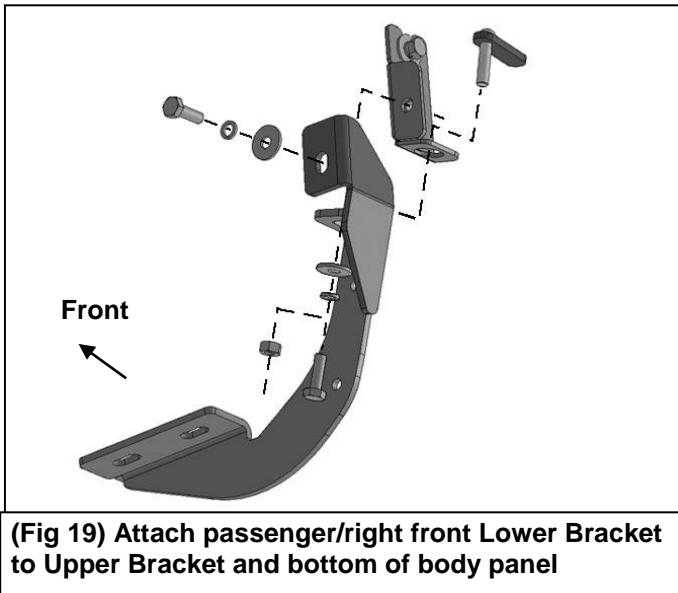
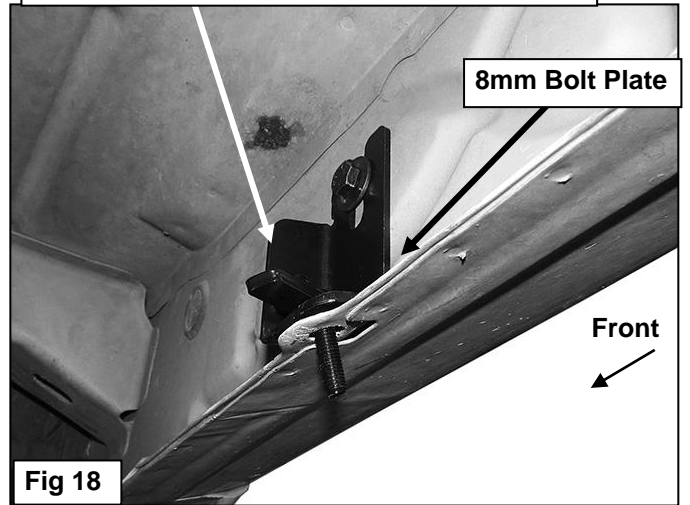

### Passenger/right Side Installation Pictured

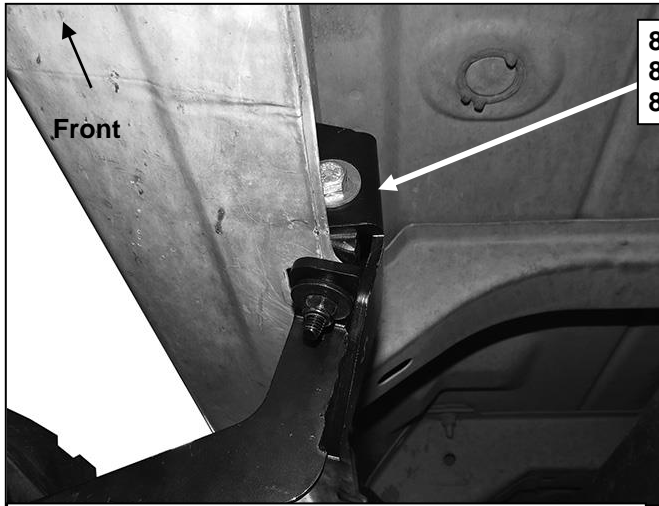

8mm x 25mm Hex Bolt  
8mm Lock Washer  
8mm Flat Washer

(Fig 20) Passenger/front Lower Bracket installed

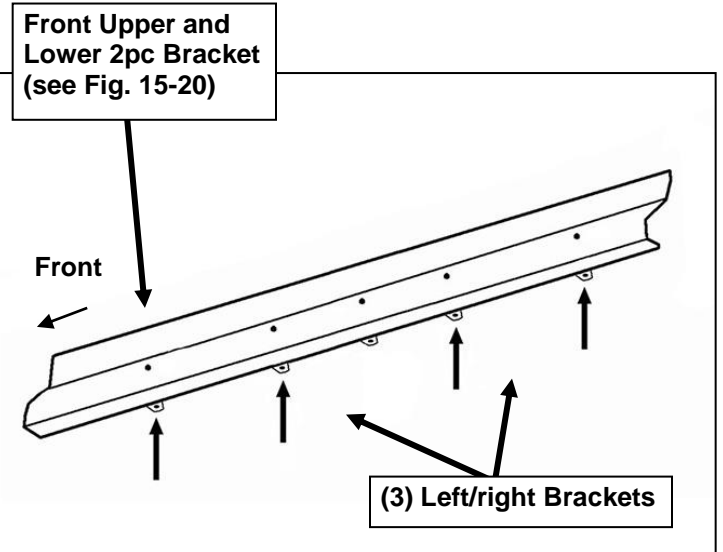

Front Upper and Lower 2pc Bracket (see Fig. 15-20)

(3) Left/right Brackets

(Fig 21) Passenger side mounting locations from back of body panel

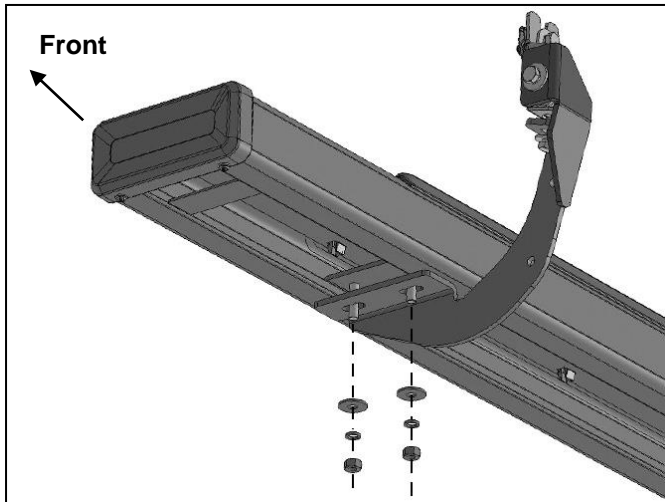

(Fig 22) Attach Side Bar to passenger/right Brackets (front 2pc upper and lower Bracket illustrated)

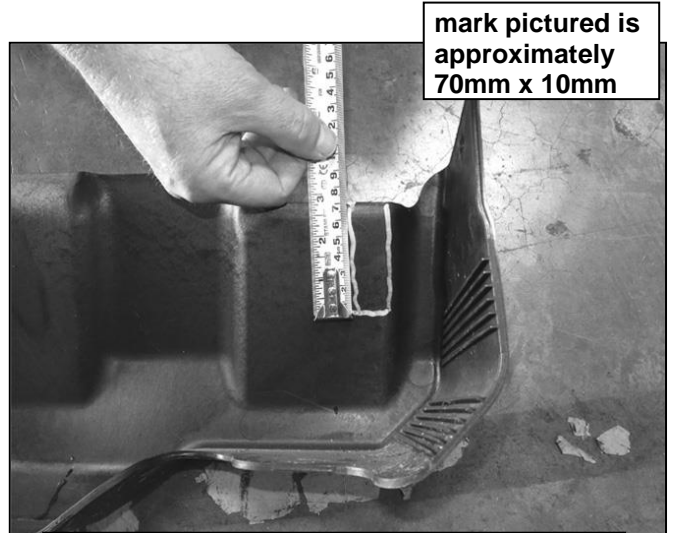

mark pictured is approximately 70mm x 10mm

(Fig 23) Cut 2017-on Passenger side DEF cover to clear 2nd Bracket only (see Fig 21)

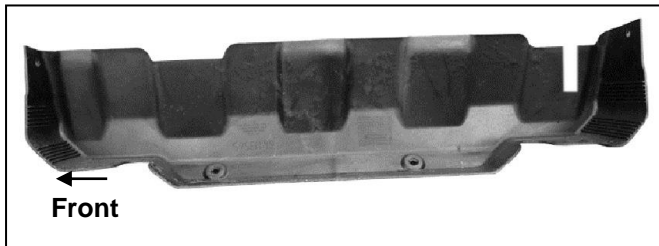

(Fig 24) 2017-on DEF cover cut for example only