

**Parts List:**

1	Driver/left side Upgraded 4" Oval Str. Sidebar	2	Passenger/right side Center & Rear Support Brackets
1	Passenger/right side Upgraded 4" Oval Str. Sidebar	6	10-1.5mm x 30mm Hex Bolts
1	Driver/left side Front Mounting Bracket	12	10mm x 24mm x 2mm Flat Washers
1	Passenger/right side Front Mounting Bracket	6	10-1.5mm Nylon Lock Nuts
1	Driver/left side Center Mounting Bracket	12	8-1.25mm Combo Bolts
1	Passenger/right side Center Mounting Bracket	6	8-1.25mm x 35mm Hex Bolts
1	Driver/right side Rear Mounting Bracket	6	8mm x 28mm x 3mm Flat Washers
1	Passenger/right side Rear Mounting Bracket	6	8mm Lock Washers
1	Driver/left side Front Support Bracket	12	6-1.0mm x 25mm Hex Bolts
1	Passenger/right side Front Support Bracket	24	6mm x 22mm x 2mm Flat Washers
2	Driver/left side Center & Rear Support Brackets	12	6-1.0mm Nylon Lock Nuts

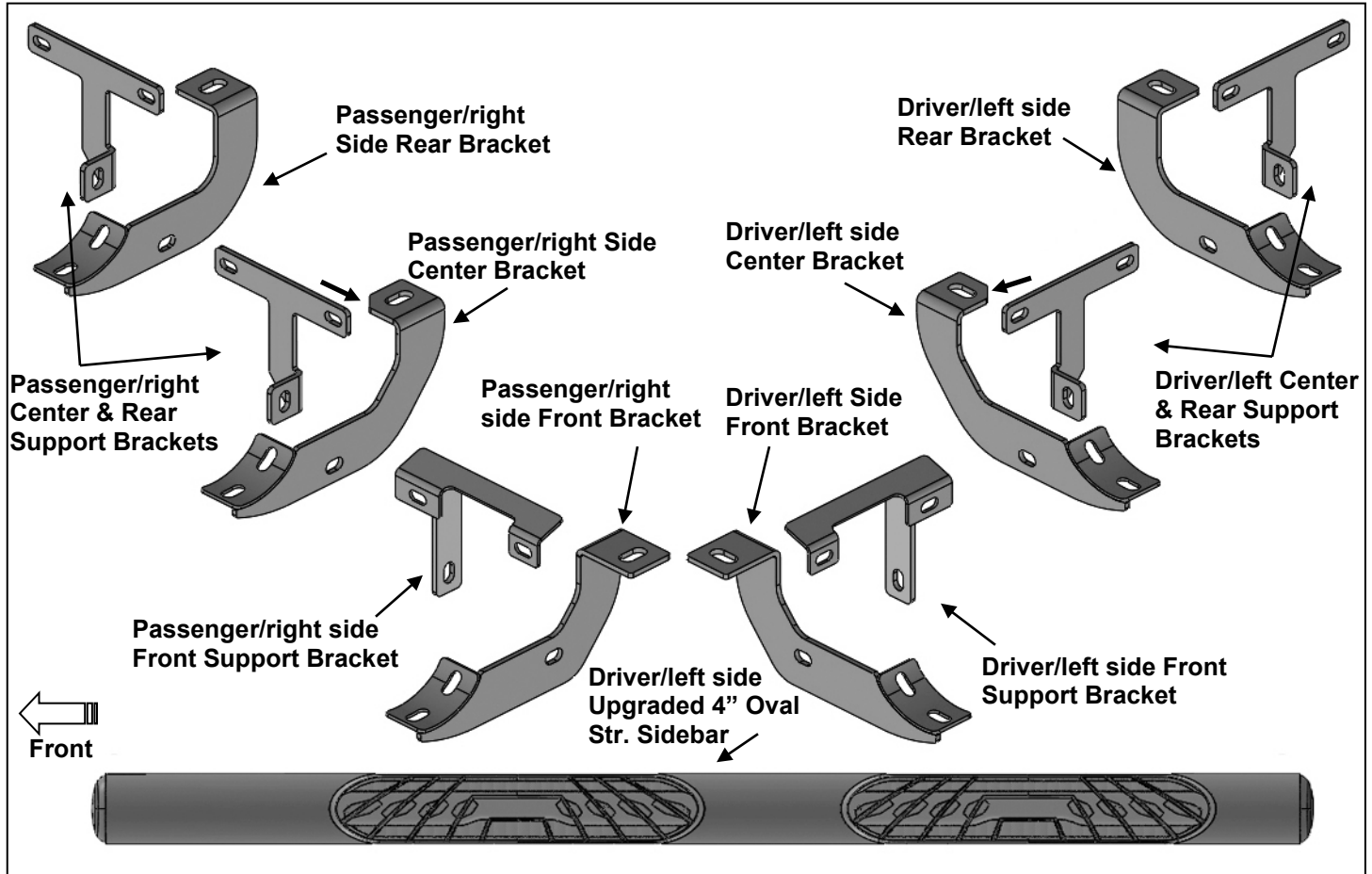

**PROCEDURE:**

1. REMOVE CONTENTS FROM BOX. VERIFY ALL PARTS ARE PRESENT. READ INSTRUCTIONS CAREFULLY BEFORE STARTING INSTALLATION. FACTORY INSTALLED OR AFTERMARKET "ROCK RAILS," SIDE STEPS OR RUNNING BOARDS MUST BE REMOVED.
2. Start installation toward the front of the driver side of the vehicle and find the front threaded insert located in between the first pair of holes along the pinch weld, (Figure 1).
3. Select the Driver/left side Front Mounting Bracket, (Figure 2). **IMPORTANT:** Use the illustration above and Figure 3 to properly identify the Mounting Bracket. Attach the Bracket to the threaded insert using (1) 8mm Hex Bolt, (1) 8mm Lock Washer and (1) 8mm Flat Washer, (Figure 3). Do not tighten hardware at this time.
4. Next, select the Driver/left side Front Support Bracket, (Figure 4). **IMPORTANT:** Use the illustration above to help identify the correct Support Bracket. Align the Bracket to the back of the pinch weld and

to the **rear** side of the Front Mounting Bracket. Attach the Support Bracket to the pinch weld using (2) 6mm Hex Bolts, (4) 6 mm Flat Washers and (2) 6mm Nylon Lock Nuts, (**Figures 4 & 5**). **NOTE:** Insert bolts from the outside of the pinch weld and through the Bracket. Use (1) 10mm Hex Bolt, (2) 10mm Flat Washers and (1) 10mm Nylon Lock Nut to secure the Support Bracket to the Mounting Bracket, (**Figures 4 & 5**). Do not tighten hardware at this time.

5. Move along the body panel to the center mounting location and locate the threaded insert and pair of holes on the pinch weld, (**Figure 6**). Repeat **Steps 3 & 4** to install the Center Brackets, (**Figures 8 & 9**). **NOTE:** The Center and Rear Mounting Brackets look similar but each one is unique. Notice the bottom corner trim on the Center Mounting Bracket in the illustration above and **Figure 7**.
6. Move to the last, rear, mounting location and locate the threaded insert and pair of holes on the pinch weld, (**Figure 10**). Repeat **Steps 3 & 4** to install the Rear Brackets, (**Figures 11 & 12**). **NOTE:** The Center and Rear Mounting Brackets look similar but each one is unique. Notice the rounded corners on the Rear Mounting Bracket in the illustration above and **Figure 7**.
7. Select the Driver/left Sidebar. Use the illustration above to select the correct Sidebar. Carefully position the Sidebar onto the (3) Mounting Brackets. **IMPORTANT:** Do not slide, (front to back or rotate), the Sidebar on the Brackets or damage to the finish on the Sidebar may result. Attach the Sidebar to the Mounting Brackets with (6) 8mm x 25mm Combination Hex Bolts, (**Figures 13—15**). Do not tighten hardware. **NOTE:** Mounting cradles on Brackets should be inline and pointing toward the rear of the vehicle for proper installation. Snug all hardware but do not tighten.
8. Level and adjust the Sidebar and tighten all hardware.
9. Repeat **Steps 1—8** for Passenger/right Sidebar installation.
10. Do periodic inspections to the installation to make sure that all hardware is secure and tight.

**To protect your investment**, wax this product after installing. Regular waxing is recommended to add a protective layer over the finish. Do not use any type of polish or wax that may contain abrasives that could damage the finish. Mild soap may be used to clean Sidebar.

### Driver/Left Side Installation Pictured

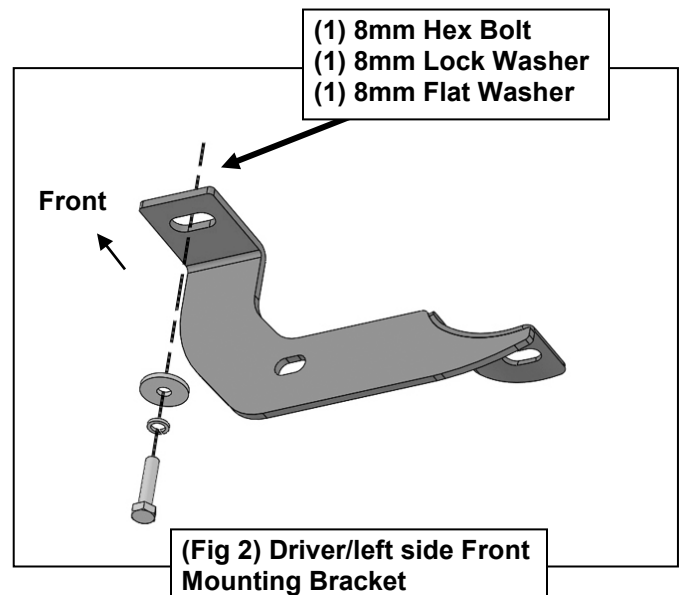
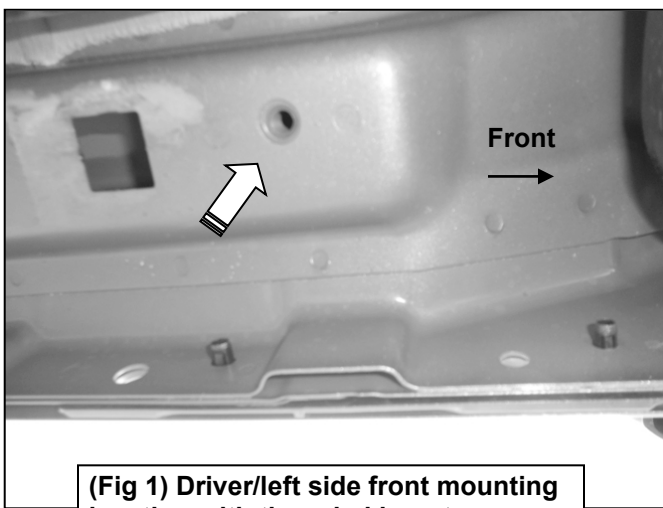

### Driver/Left Side Installation Pictured

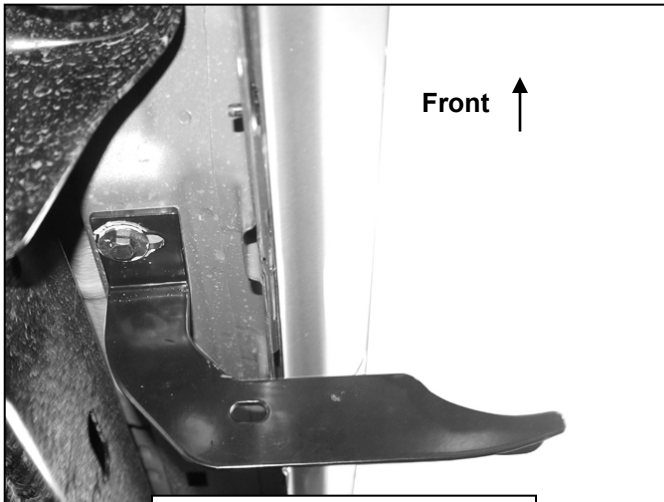

(Fig 3) Driver/left side Front Mounting Bracket installed

- (2) 6mm Hex Bolts
- (4) 6mm Flat Washers
- (2) 6mm Nylon Lock Nuts

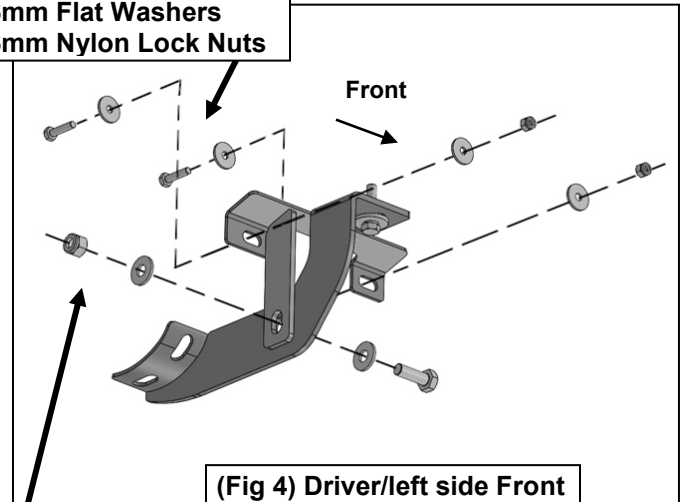

(Fig 4) Driver/left side Front Support Bracket

- (2) 6mm Hex Bolts
- (4) 6mm Flat Washers
- (2) 6mm Nylon Lock Nuts

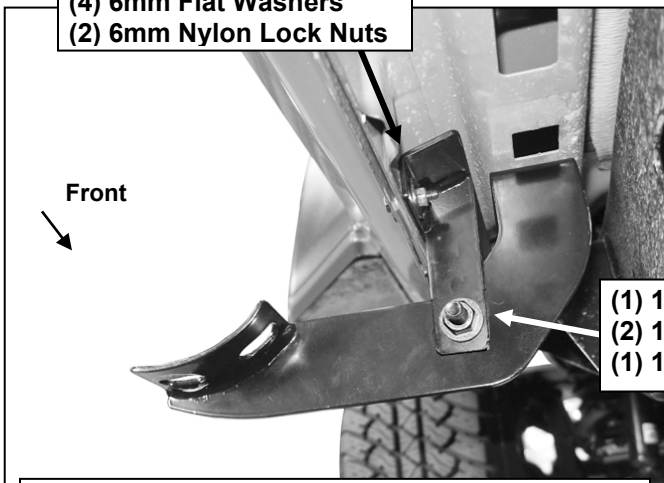

- (1) 10mm Hex Bolt
- (2) 10mm Flat Washers
- (1) 10mm Nylon Lock Nut

(Fig 5) Attach Support Bracket to back of pinch weld and to rear side of Mounting Bracket

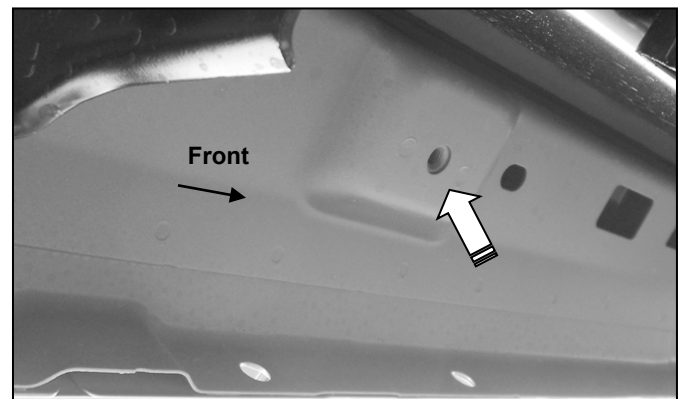

(Fig 6) Driver/left side center mounting location

### Driver/left Side Installation Pictured

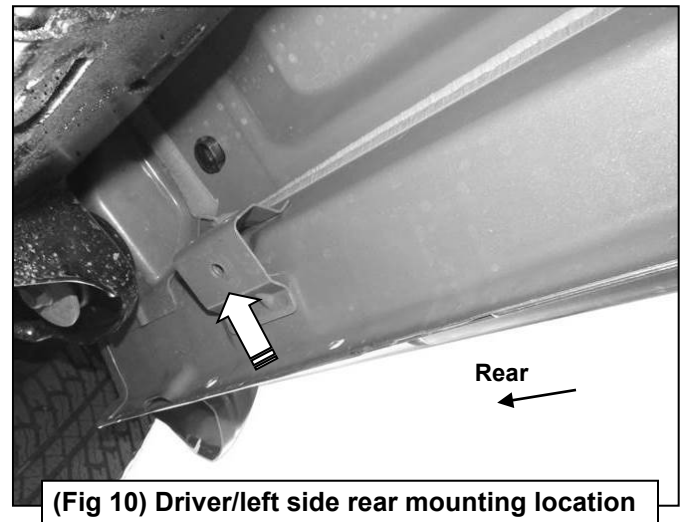
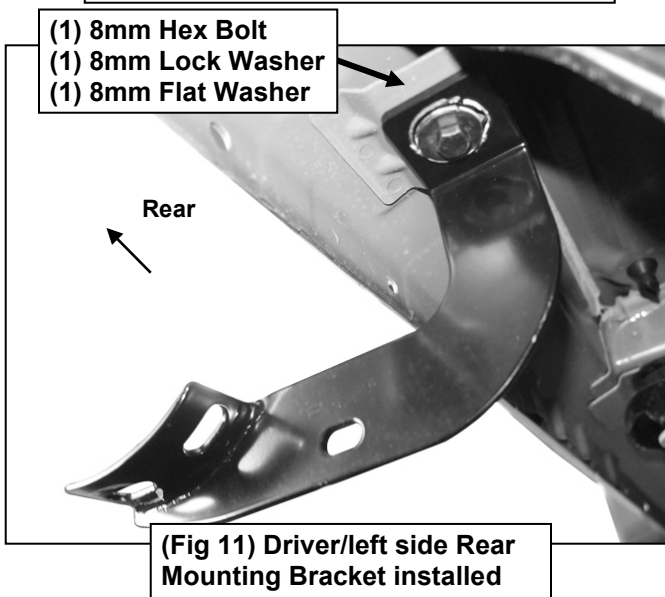
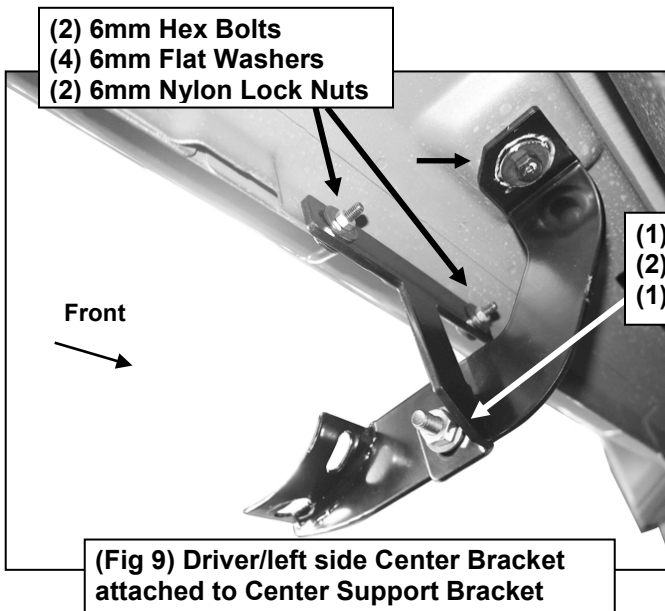
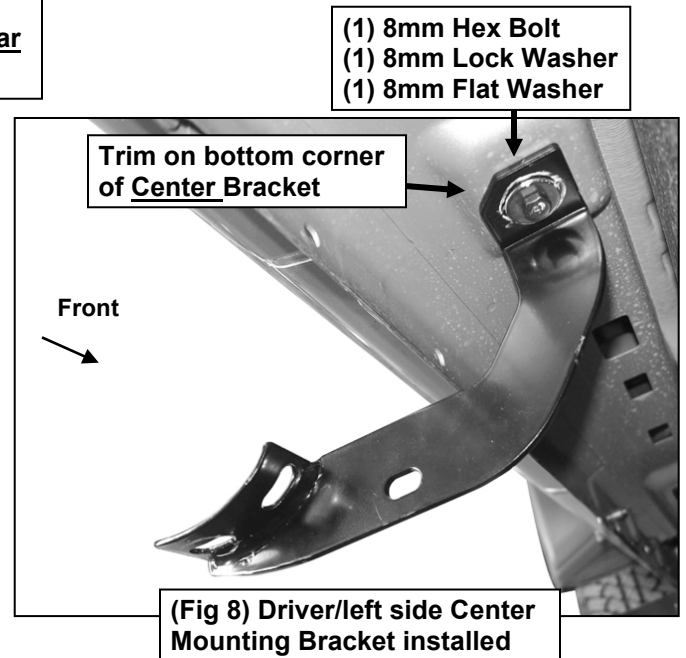
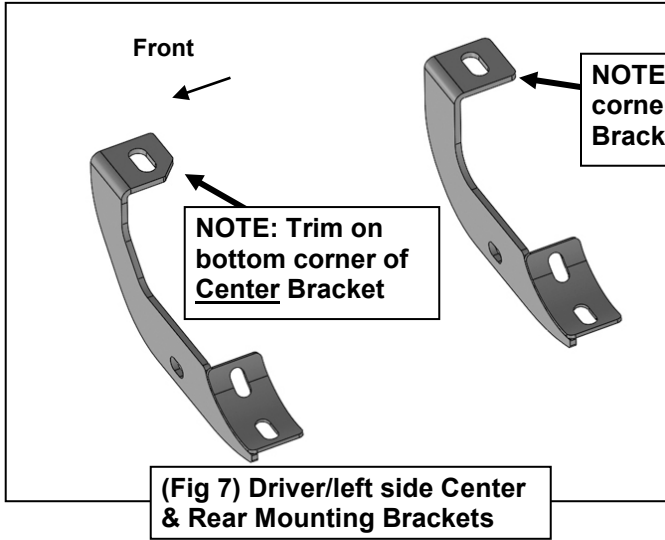

### Driver/left Side Installation Pictured

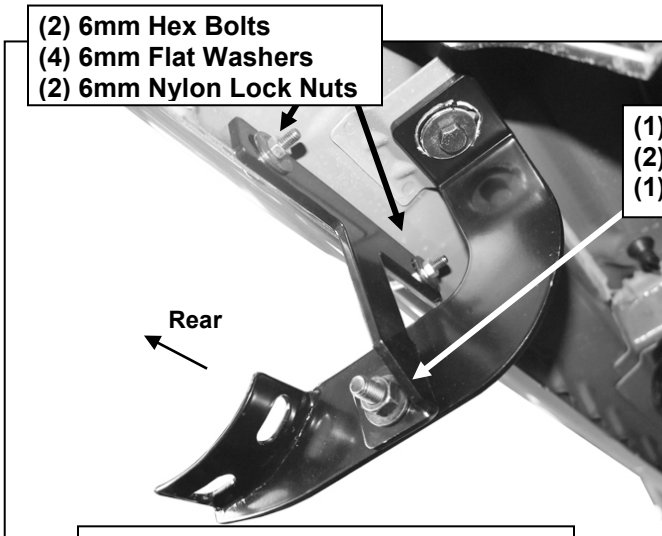

(Fig 12) Driver/left side Rear Bracket attached to Rear Support Bracket



(Fig 13) Driver/left side Front Brackets attached to Sidebar

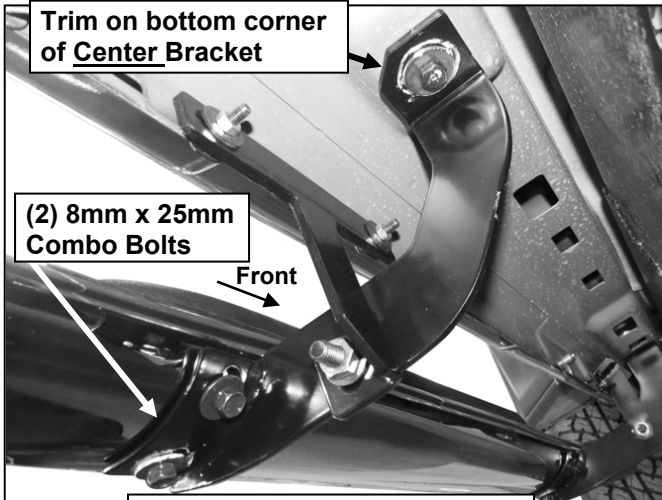

(Fig 14) Driver/left side Center Brackets attached to Sidebar

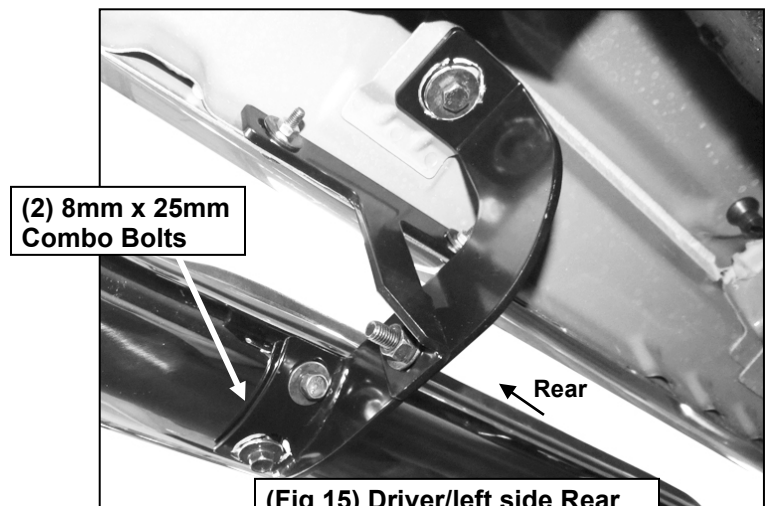

(Fig 15) Driver/left side Rear Brackets attached to Sidebar