

PARTS LIST:

Qty	Description	Qty	Description
1	Bull Bar	4	12-1.75mm x 35mm Hex Bolts
1	Driver/Left Mounting Bracket	8	12mm x 32mm OD x 3mm Large Flat Washers
1	Passenger/Right Mounting Bracket	4	12mm x 24mm OD x 2.5mm Flat Washers
4	12mm x 40mm Bolt Plates	8	12mm Hex Nuts
8	12mm Lock Washers		

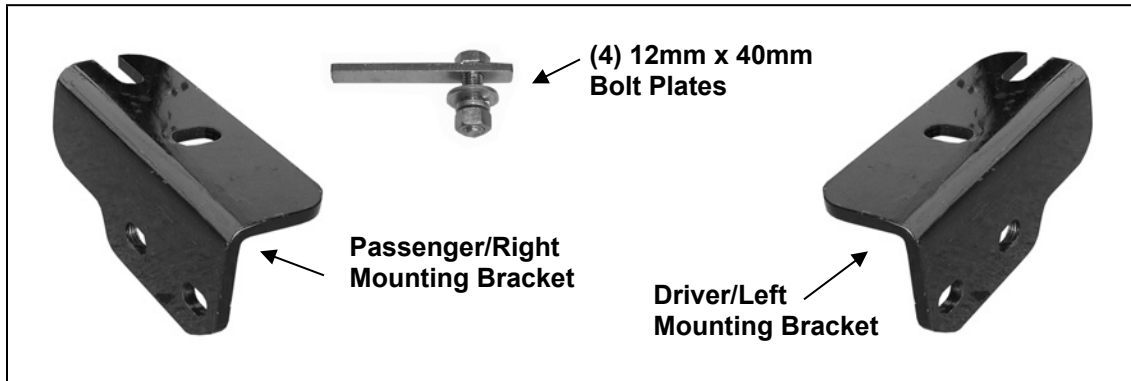

PROCEDURE:

- 1. REMOVE CONTENTS FROM BOX. VERIFY ALL PARTS ARE PRESENT. READ INSTRUCTIONS CAREFULLY BEFORE STARTING INSTALLATION. CUTTING MAY BE REQUIRED.**

2. Vehicles with Factory Tow Hooks

Remove the driver side tow hook by removing the front bolt and loosening the rear bolt, **(Figure 1)**. Slide the tow hook off. Leave the rear bolt in place to hold the double nut plate in the frame and aligned with the holes. **NOTE:** This Bull Bar is not compatible with the factory tow hooks and tow hooks will not be reinstalled.

Position the driver side Mounting Bracket up to the bottom of the frame, **(Figure 2)**. Slide the Bracket under the rear bolt. Bolt the Bracket in place with the factory tow hook bolts and factory double nut plate. Repeat for passenger side Bracket installation.

Vehicles without Tow Hooks

Remove the plastic lower bumper cover, **(Figure 4)**. Insert (2) 12mm Bolt Plates through the opening in the open front end of the frame on the driver side and down through the holes in the bottom of the frame, **(Figure 2)**. Bolt the Bracket to the Bolt Plates with (2) 12mm x 24mm STD Flat Washers, (2) 12mm Lock Washers and (2) 12mm Hex Nuts. Snug but do not tighten the hardware at this time. Repeat for passenger side Bracket installation.

- 3. With assistance, position the Bull Bar onto the inside of the Mounting Brackets, (Figure 3).** Use the included (4) 12mm x 35mm Hex Bolts, (8) 12mm x 32mm Large Flat Washers, (4) 12mm Lock Washers and (4) 12mm Hex Nuts to attach the Bull Bar to the Mounting Brackets. Do not tighten at this time.

- 4. Align and adjust the Bull Bar properly, and tighten all hardware.**

IMPORTANT-Vehicles without Tow Hooks only

Temporarily remove the Bull Bar. Hold the plastic cover up in position and trace the outline of the Brackets onto the inside of the cover, **(Figures 4 & 5)**. Use a sharp knife or hacksaw blade to carefully cut the openings for the Brackets. Make small cuts and check the fit often for best

results. Once properly trimmed to clear the Brackets, reinstall the cover. Reinstall the Bull Bar as described in **Steps 3 & 4**.

5. Do periodic inspections to the installation to make sure that all hardware is secure and tight.

To protect your investment, wax this product after installing. Regular waxing is recommended to add a protective layer over the finish. Do not use any type of polish or wax that may contain abrasives that could damage the finish.

For stainless steel: Aluminum polish may be used to polish small scratches and scuffs on the finish. Mild soap may be used also to clean the Bull Bar.

For gloss black finishes: Mild soap may be used to clean the Bull Bar.

Driver Side Installation Pictured

Remove tow hooks if equipped

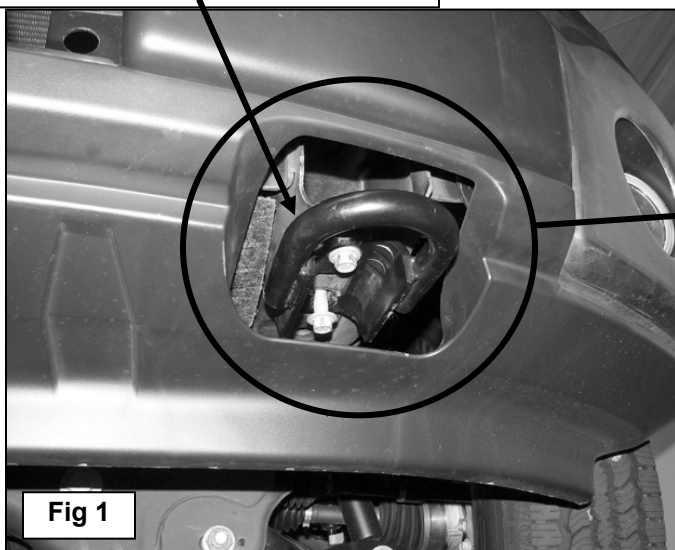

NOTE: On vehicles without tow hooks, the area circled above may be covered, (see **Figure 4**). Remove the lower plastic bumper cover to access the front of the frame channel for Bracket installation

Fig 1

Insert Bolt Plates through opening in end of frame channel



Use the factory tow hook hardware or the included:
(2) 12mm x 40mm Bolt Plates
(2) 12mm Flat Washers
(2) 12mm Lock Washers
(2) 12mm Hex Nuts

Fig 2

Driver Side Installation Pictured

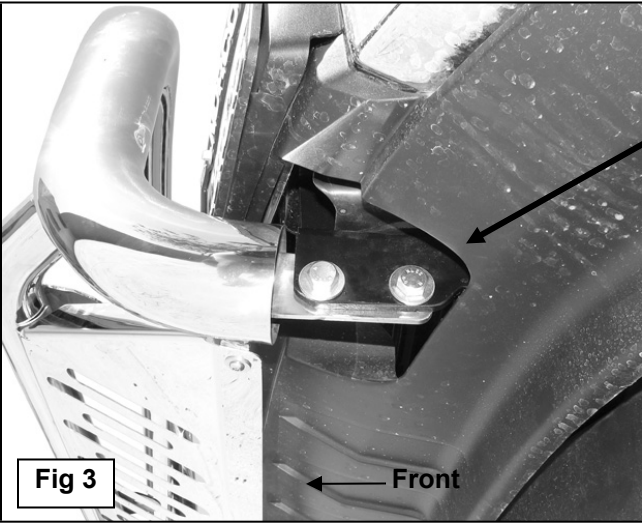

- (2) 12mm x 35mm Hex Bolts
- (4) 12mm x 32mm Large Flat Washers
- (2) 12mm Lock Washers
- (2) 12mm Hex Nuts



Do not cut through the front edge of the cover

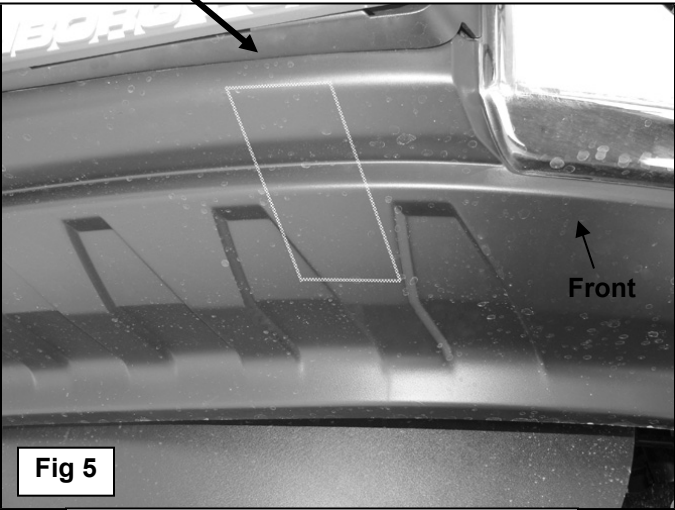

NOTE: Outline illustrated for example only. Only remove enough plastic for Bracket clearance. Do not cut through the front or rear edge of the cover.

Models without tow hooks: Install and adjust Brackets and Bull Bar. Temporarily remove the Bull Bar. Hold plastic cover up against Brackets. Mark outline of Brackets onto back of cover

