

PARTS LIST:

Qty	Description	Qty	Description
1	Grille Guard	8	12-1.75mm x 35mm Hex Bolts
2	Upper Frame Mounting Brackets (for trucks without tow hooks only)	22	12mm x 32mm OD x 3mm Flat Washers
1	Driver/Left Lower Frame Mounting Bracket	14	12mm Lock Washers
1	Passenger/Right Lower Frame Mounting Bracket	12	12-1.75mm Hex Nuts
1	Driver/Left Upper Support Bracket	4	8mm x 20mm Button Head Allen Bolts
1	Passenger/Right Upper Support Bracket	4	8mm x 22mm OD x 2mm Flat Washers
1	Driver/Left Lower Support Bracket	4	8mm Lock Washers
1	Passenger/Right Lower Support Bracket	2	5-.8mm x 15mm Button Head Allen Bolt
2	12-1.5mm x 30mm Special Fine Thread Hex Bolt (for trucks without tow hooks only)	4	5mm x 10mm OD x 1mm Flat Washers
1	Wrench	2	5mm Nylon Lock Nuts

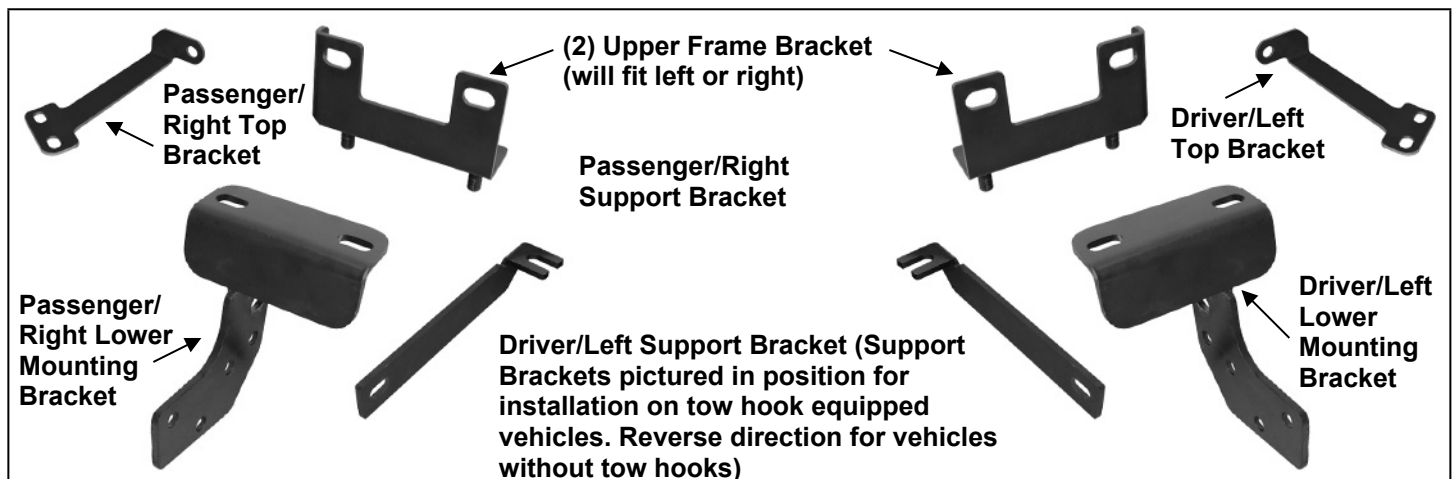

PROCEDURE:

1. **REMOVE CONTENTS FROM BOX. VERIFY ALL PARTS ARE PRESENT. READ INSTRUCTIONS CAREFULLY BEFORE STARTING INSTALLATION. CUTTING IS REQUIRED. ASSISTANCE IS RECOMMENDED.**
2. Starting at the underside of the front bumper, carefully remove the plastic splash guard. **NOTE:** Depending on the model of truck, the splash guard may be attached to the bottom of the truck with hex bolts and several two-piece plastic push-in clips. Remove all hex bolts then locate the clips behind the bumper cover, **(Figure 1A)**. Pry up on the center pin of the clip with a small flat blade screwdriver and remove the entire clip, **(Figure 1B)**. Pay close attention to the type and location of all factory hardware for reinstallation. The splash guard may also be attached to the bumper cover with rivets at the corners. Use wire cutters to remove the rivets. Once all fasteners have been removed, move splash guard to a clean stable work area.
3. Next, determine if the truck is equipped with tow hooks.

For models without tow hooks:

 - a. Remove the hex nuts from the two lower factory bumper bolts, **(Figure 2)**.
 - b. Select (1) Frame Bracket, (will fit left or right-without tow hooks only), and the driver side Mounting Bracket, **(Figure 3)**. Bolt the two Brackets together with (2) 12mm Flat Washers, (2) 12mm Lock Washers and (2) 12mm Hex Nuts. Snug the hardware but do not tighten at this time.
 - c. Insert the assembled Mounting Bracket up from behind the bumper and align the holes in the Mounting Bracket with the bumper bolts. Attach the Bracket to the bumper bolts using the factory hex nuts and snug but do not tighten the hardware, **(Figure 4)**.

NOTE: On some vehicles, it may be easier to assemble the two-piece bracket on the vehicle. Install the Upper Frame Bracket first, then bolt the Lower Frame Bracket to the bottom as previously described.

- d. Install the driver side Lower Support Bracket with the bent end toward the front of the vehicle, **(Figure 3)**. Bolt the Support Bracket to the inside of the Lower Mount using the top round hole in the Lower Mounting Bracket with the included (1) 12mm x 35mm Hex Bolt, (2) 12mm Flat Washers, (1) 12mm Lock Washer and (1) 12mm Hex Nut, **(Figure 4)**.
- e. Attach the flat end of the driver side Bracket to the frame with (1) 12-1.5mm x 30mm **Special Fine Thread** Hex Bolt, (1) 12mm Flat Washer and (1) 12mm Lock Washer, **(Figure 4)**. **IMPORTANT:** The hole in the bottom of the frame is **fine thread**. Only use the 12-1.5mm x 30mm Hex Bolt provided in the hardware kit. Snug but do not tighten all hardware at this time.

For models with tow hooks:

- a. Remove the (2) hex nuts holding the front of the tow hook to the back of the bumper, **(Figure 5)**.
 - b. Select the driver side Lower Mounting Bracket, **(Figure 6)**. Hang the Bracket from the tow hook mounting studs using the factory Hex Nuts, **(Figure 7)**. Do not tighten hardware at this time.
 - c. Bolt the flat end of the driver side Support Bracket to the inside of the Lower Mounting Bracket using the second round hole from the top, **(Figures 6 & 8)**. Use the included (1) 12mm x 35mm Hex Bolt, (2) 12mm Flat Washers, (1) 12mm Lock Washer and (1) 12mm Hex Nut.
 - d. Attach the bent end of the Support Bracket to the rear tow hook bolt. Loosen the rear mounting bolt for the tow hook. Insert the slotted end under the head of the factory bolt, **(Figure 8)**.
 - e. Snug but do not tighten all hardware at this time.
4. Repeat the appropriate **Step 3** for the passenger side Mounting Bracket installation.
 5. Move to the top of the grille opening and open the hood, **(Figure 9)**. Remove the driver side inner headlight mounting screw. Insert the driver side Top Bracket between the radiator support and the headlight housing, **(Figure 10)**. Reinstall the factory hex bolt and snug but do not tighten at this time. Repeat this **Step** for the passenger side Top Bracket installation.
 6. With assistance, hold the Grille Guard up to the outside of the Mounting Brackets. Bolt the Grille Guard to the Brackets with (6) 12mm x 35mm Hex Bolts, (12) 12mm Flat Washers, (6) 12mm Lock Washers and (6) 12mm Hex Nuts, **(Figure 11)**. Do not tighten hardware at this time.
 7. Line up the driver side Top Bracket with the (2) threaded inserts in the bottom of the headlight guard tube. Bolt the Bracket to the inserts with (2) 8mm x 20mm Button Head Allen Bolts, (2) 8mm x 22mm x 1.5mm Flat Washers and (2) 8mm Lock Washers, **(Figure 12)**. Repeat this Step to attach the passenger side Top Bracket. Do not tighten hardware at this time.
 8. **IMPORTANT:** Slowly close the hood to check for clearance between the hood and the Top Brackets. Adjust as necessary then snug but do not tighten the hardware.
 9. Stand back from the vehicle and check to see that the Grille Guard is centered and level on the vehicle and adjust as necessary. **IMPORTANT:** Once properly aligned, tighten only the hardware securing the lower frame Mounting Brackets to the truck. Do not tighten the hardware on the Grille Guard.
 10. Remove the Grille Guard but leave the lower Mounting Brackets on the vehicle.
 11. Next, hold the splash guard up to the bumper cover and align it with the mounting points, **(Figure 13)**. Mark the location of the Mounting Brackets onto the back of the splash guard. Cut an approximately 1/2" wide by 4" long slot in the splash guard as pictured in **Figure 14**. **NOTE:** The size of the slot is an estimate only and may vary due to different factory designs for the splash guards and front bumper covers. Also, additional cutting may be required to clear the Support Bracket on vehicles equipped with tow hooks. **IMPORTANT:** To maintain the integrity of the splash guard, do not cut the slot any larger than necessary. Do not cut through the front or back edges of the cover, **(Figure 14)**. Make several small cuts first and check the fit often for a clean installation.
 12. Check the fit and reinstall the splash guard using the factory hardware. Use the included (2) 5mm x 15mm Allen Bolts, (4) 5mm Flat Washers and (2) 5mm Lock Nuts to replace the rivets if required, **(Figure 15)**.
 13. Re-install, level and adjust the Grille Guard as described in **Step 7**. Tighten all hardware.
 14. Do periodic inspections of the installation to make sure that all hardware is secure and tight.

To protect your investment, wax this product after installing. Regular waxing is recommended to add a protective layer over the finish. Do not use any type of polish or wax that may contain abrasives that could damage the finish.

For stainless steel: Aluminum polish may be used to polish small scratches and scuffs on the finish. Mild soap may be used also to clean the Grille Guard.

For gloss black finishes: Mild soap may be used to clean the Grille Guard

Driver Side Installation Pictured

Pry up the center pin to remove the complete fastener

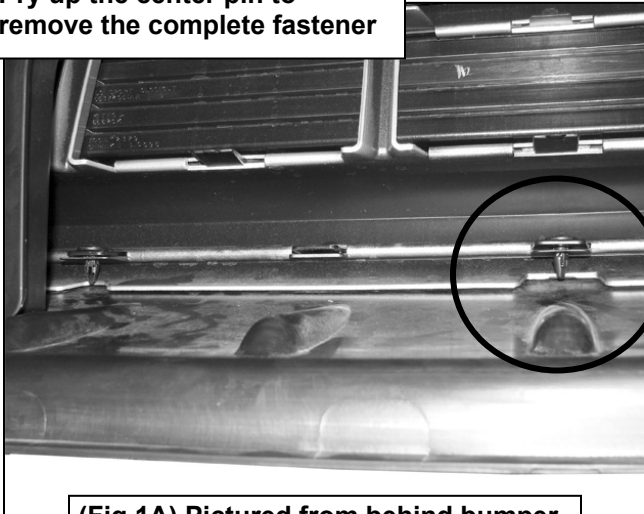

(Fig 1A) Pictured from behind bumper

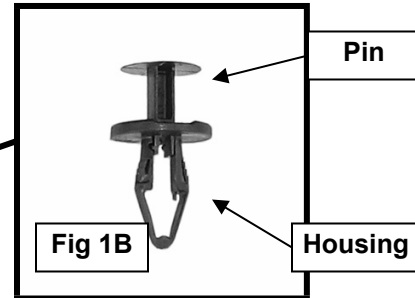

For illustration only, clips may differ depending on model and year

Remove the (2) factory hex nuts from the lower bumper bolts

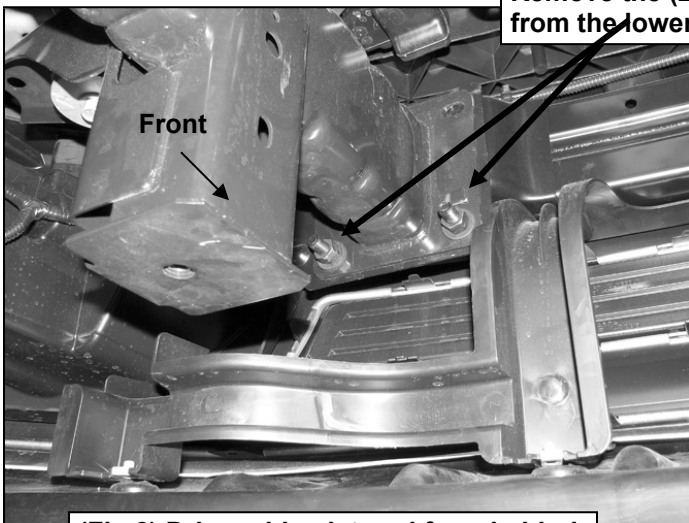

(Fig 2) Driver side pictured from behind bumper (non tow hook models)

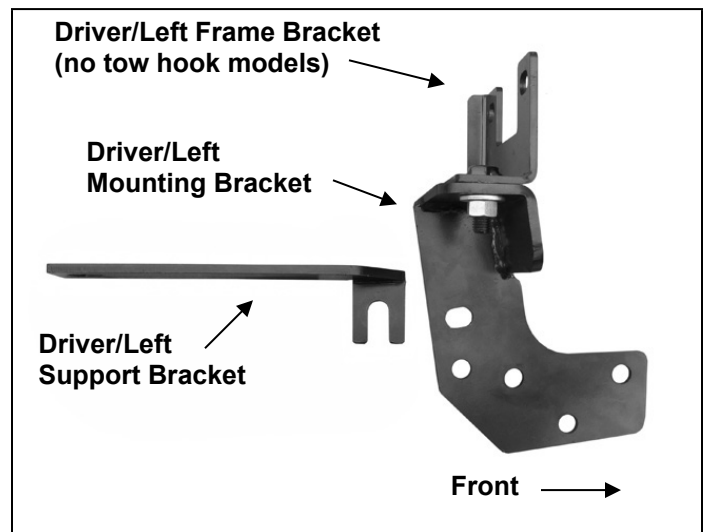

(Fig 3) Driver side Brackets Pictured (non tow hook models)

Driver Side Installation Pictured

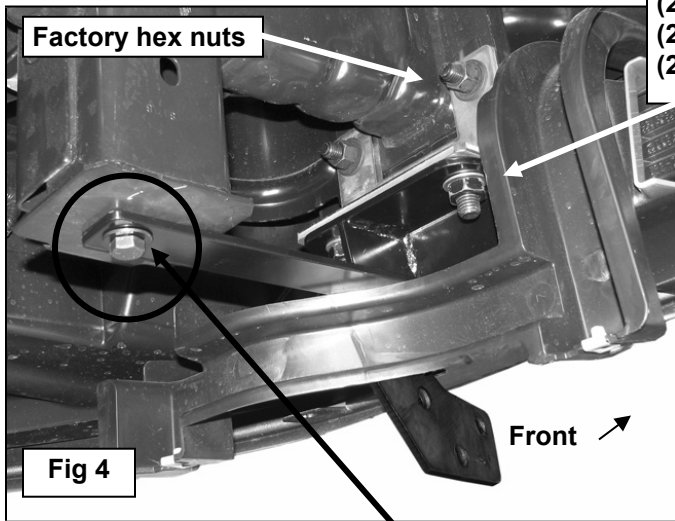

- (2) 12mm Flat Washers
- (2) 12mm Lock Washers
- (2) 12mm Hex Nuts

IMPORTANT: For models without tow hooks, only use the supplied 12-1.5mm x 30mm Fine Thread Hex Bolt 12mm Lock Washer 12mm Flat Washer

Installation pictured without the splash guard for illustration

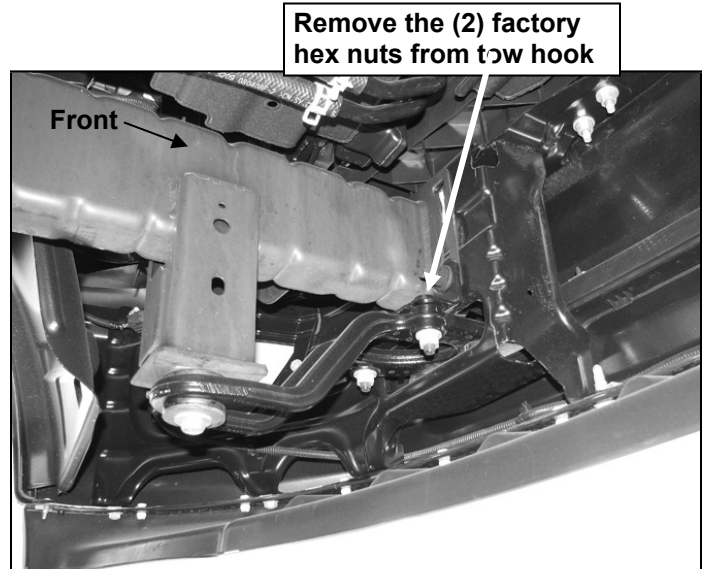

(Fig 5) Driver side mounting location pictured from behind bumper on tow hook equipped model

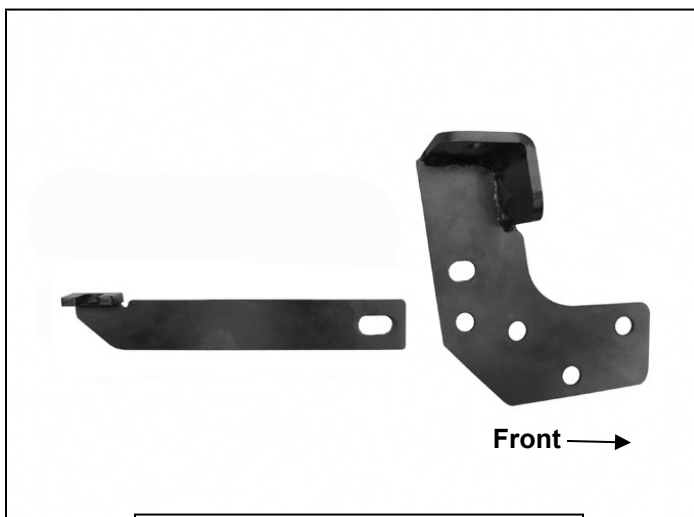

(Fig 6) Driver side Brackets pictured (models with tow hooks)

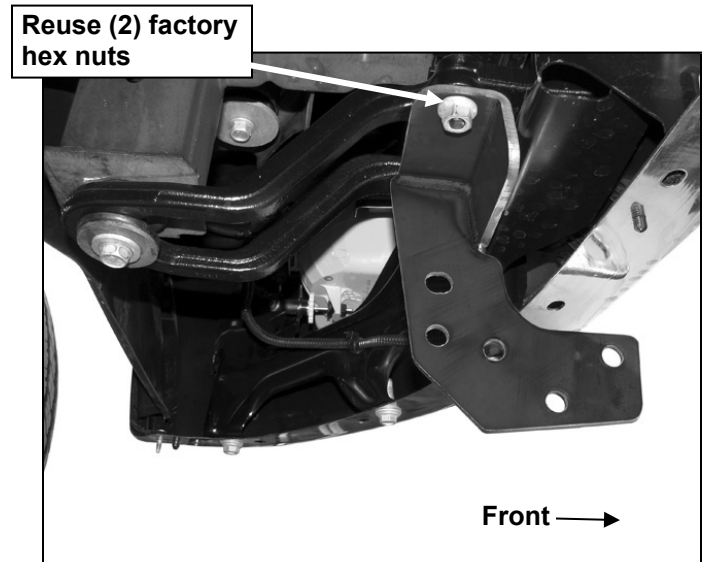

(Fig 7) Attach the driver side Frame Mounting Bracket to the bottom of the tow hook

Driver Side Installation Pictured

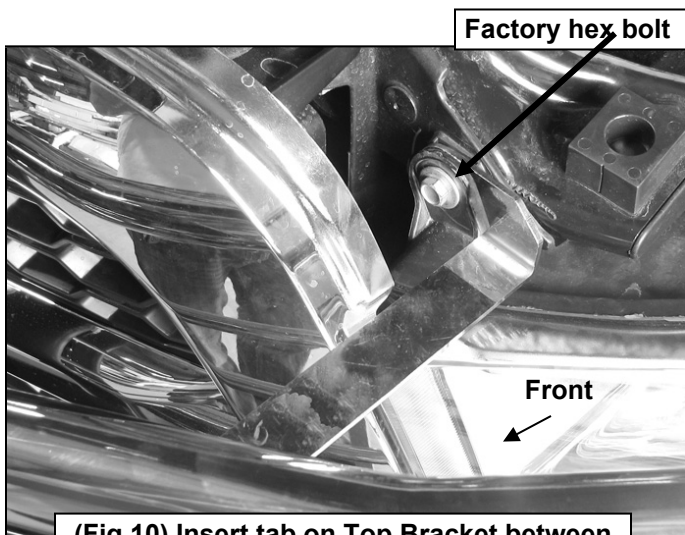
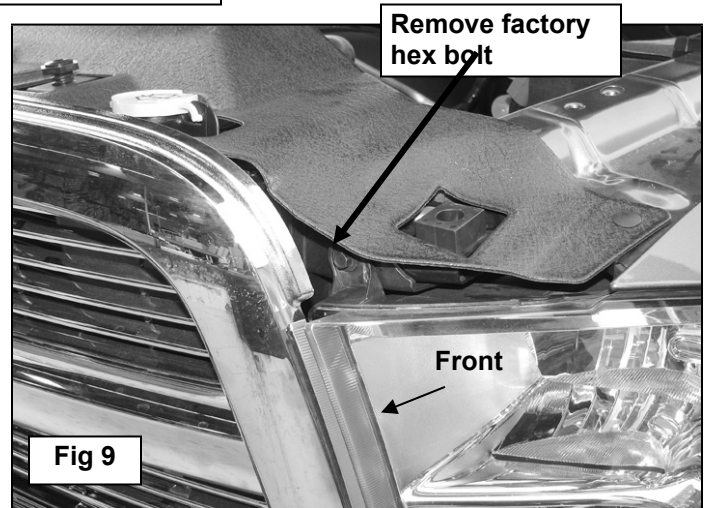
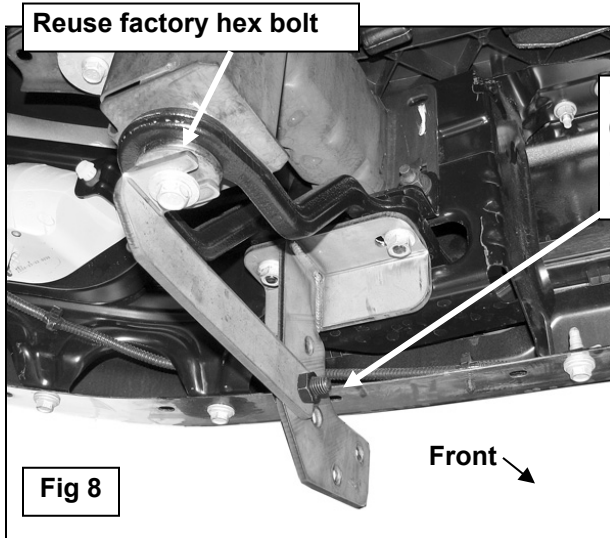

(Fig 10) Insert tab on Top Bracket between the headlight housing and radiator support

Installation pictured without the splash guard for instruction purposes only

- (3) 12mm x 35mm Hex Bolts
- (6) 12mm Flat Washers
- (3) 12mm Lock Washers
- (3) 12mm Hex Nuts

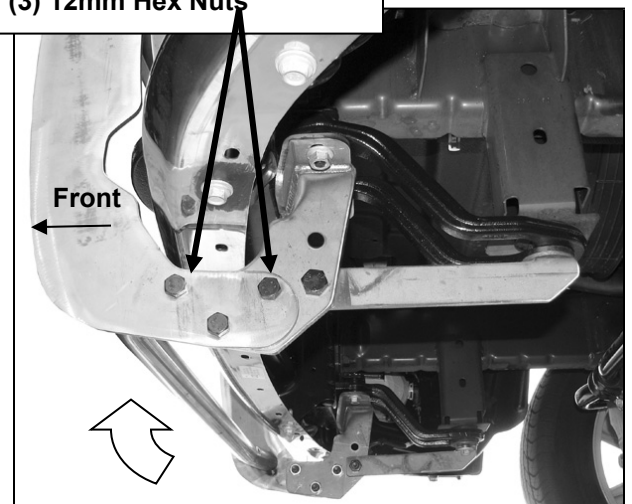

(Fig 11) Rotate the Grille Guard up into position

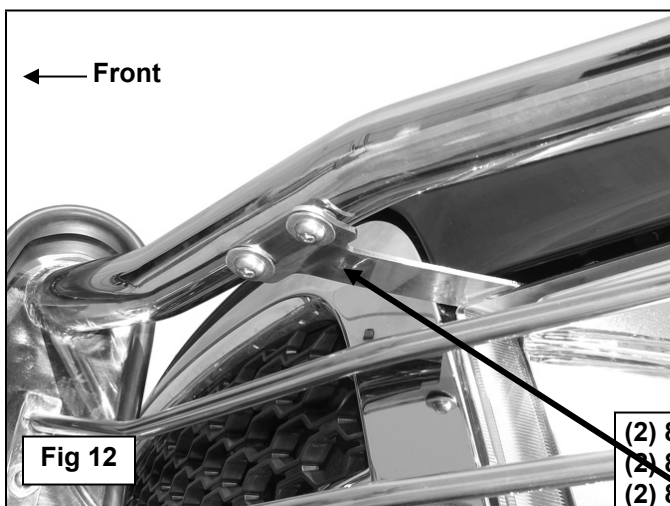

- (2) 8mm x 20mm Button Head Bolt
- (2) 8mm Lock Washers
- (2) 8mm Flat Washers

Driver Side Installation Pictured

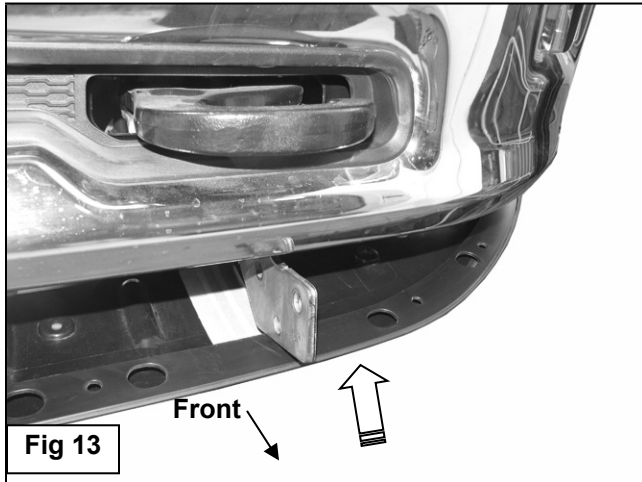

Hold the splash guard up to the brackets and mark location for cutting to clear brackets. Cut only what is needed to insert bracket through the splash guard of the splash guard.

Do not cut through the front or rear edge of the splash guard

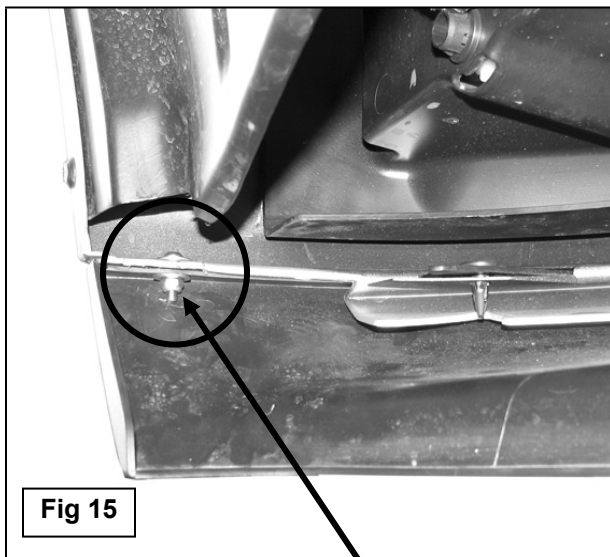
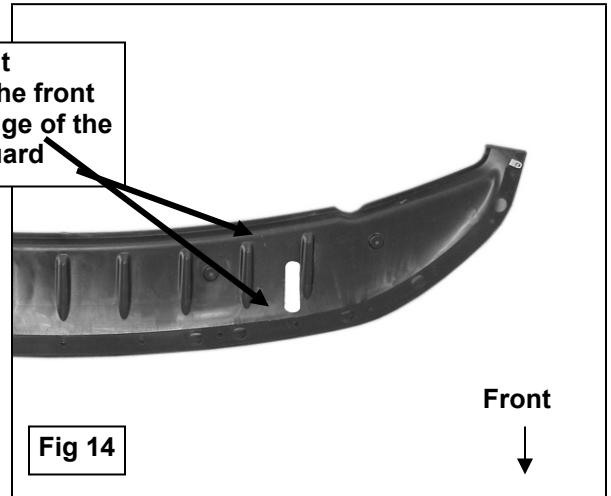

If required, replace the rivet at the corner of the splash guard with the supplied:
5mm x 15mm Button Head Allen Bolt
(2) 5mm Flat Washers
5mm Nylon Lock Nut

