

# INSTALLATION INSTRUCTIONS

## GRILLE GUARD

DODGE CHARGER 06 -08

FIGURE #1

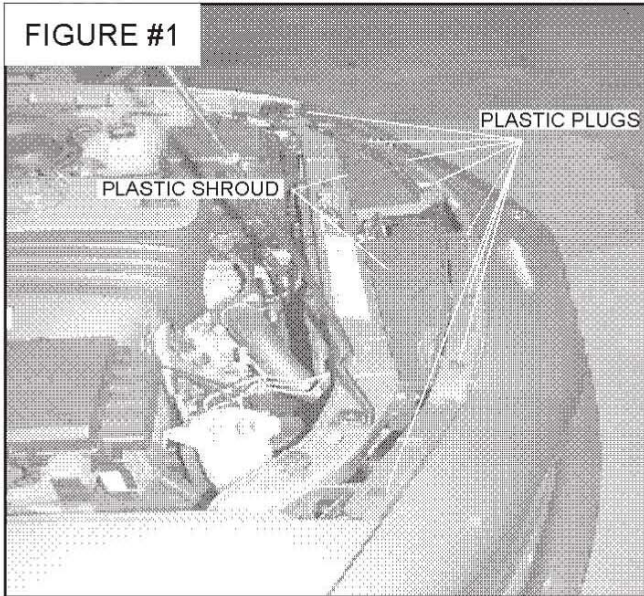

### SECTION #1 REMOVE THE FASCIA

**STEP #1:** Open the hood. Remove the two black plastic shrouds around the hood latch mechanism. See Figure #1.

**STEP #2:** Remove the eight black plastic plugs that are indicated in Figure #1 using a pair of plug pullers. The third ones in on each side are difficult to remove.

**STEP #3:** Remove the two bolts (one per side) using a 10 mm socket and ratchet. Remove the two inner nuts (one on each side) from the inside of the fender. See Figure #2 and Figure #3 (Installers note: Our installers had some difficulty reaching these nuts. The easiest way is to use a 1/4" drive air ratchet and a 10 mm deep well socket.)

FIGURE #2

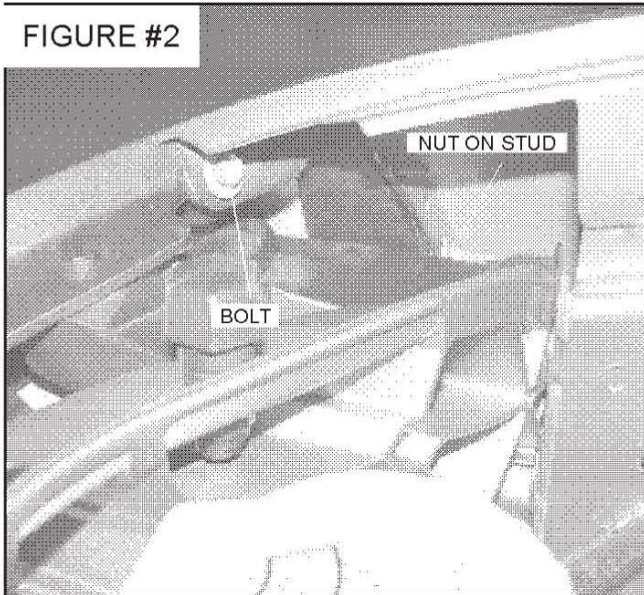

**STEP #4:** Remove the six black plastic plugs from inside each fender well (three on each side) and the two pull plugs (one on each side). Peel back the black inner fender to expose the 10 mm bolt that is holding the fascia to the fender. See FIGURE #4.

**STEP #5:** Remove the eight bolts from the bottom of the fascia using a 7 mm socket. Also remove the two lamps in the driving lights (if equipped).

**STEP #6:** Remove the fascia from the front of the vehicle. Pull from the two sides near the headlights (it is best to use two people to do this). The side marker lamps will pop off when you remove the fascia, however they are attached with wires and will not fall to the floor. Feed them back through the openings and set aside.



FIGURE #3

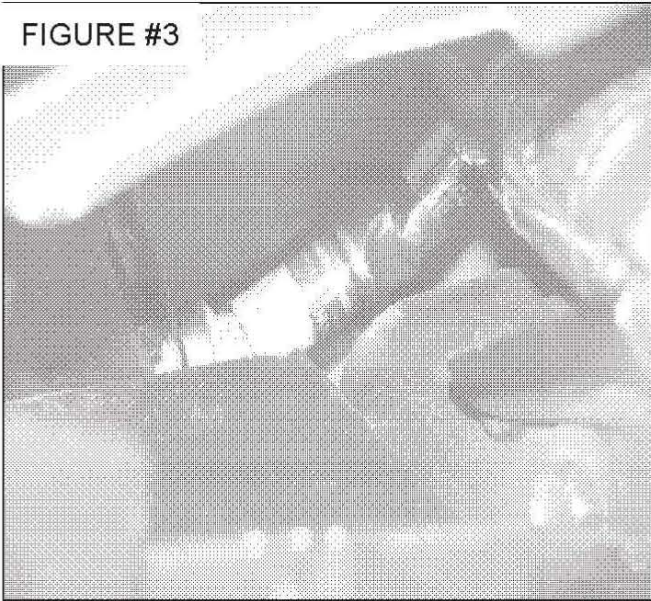

FIGURE #4

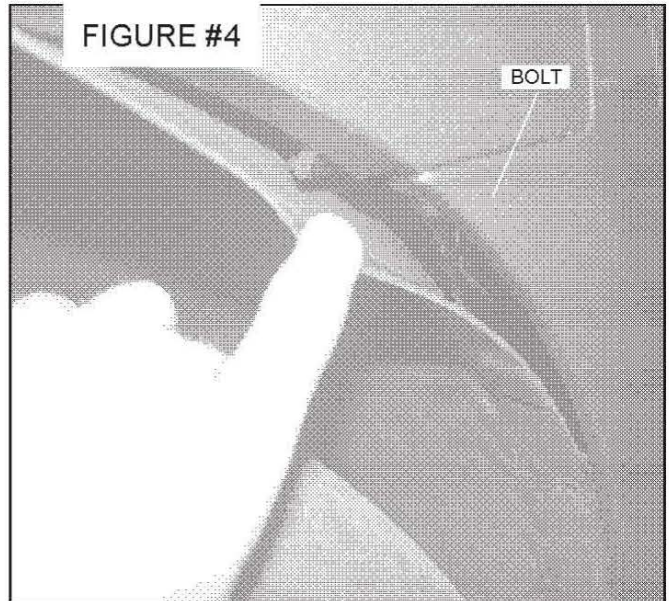

FIGURE #5

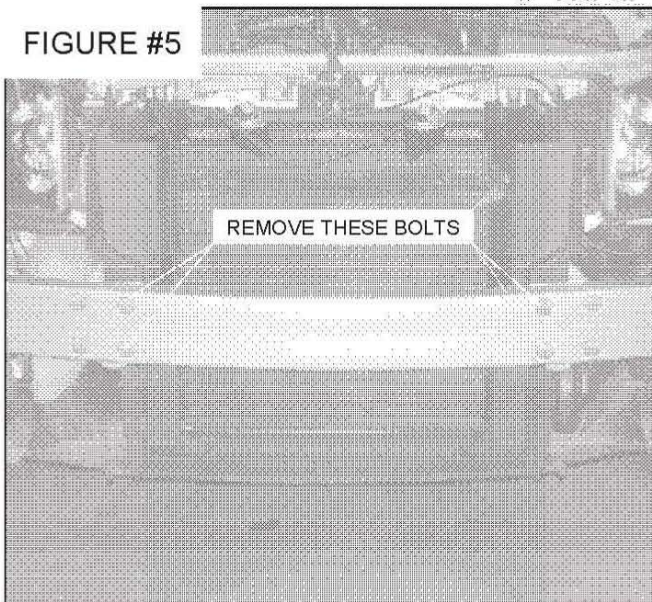
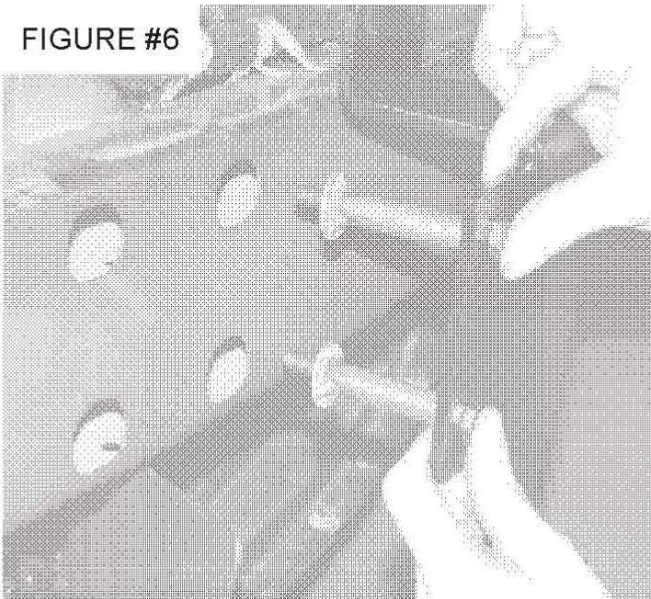

FIGURE #6



## SECTION #2 INSTALL THE BRACKETS

**STEP #1:** Locate the 8 holes in the inner bumper (4 on each side). Use a 13 mm socket on a 6" extension to remove the four innermost bolts. See Figure #5.

**STEP #2:** Get one of the inner mounting brackets with the flange on it. Place two 8 mm x 95 mm bolts through the flange and place two 3" crush tubes over the bolts. The completed assembly will look like Figure #6.

**STEP #3:** Starting with the drivers side. Place the ends of the bolts through the same holes where you removed the bolts in the inner bumper. Hold the bracket up flush to the front of the inner bumper so the side flange is pointing toward the outside of the vehicle and the bottom flange is facing forward. See figure #7. The bolts will use the factory threads in the inner bumper. Finger tighten these bolts for now to allow for adjustment later. Repeat this procedure on the passenger side.

**STEP #4:** Set the inner mounting brackets so the outer edge of the lower tab is between 29 7/8" and 30" apart. The edge of the bracket will be 12" from the end of the inner bumper. See Figure #7 Once these brackets are in place. Tighten down the bolts fully.



FIGURE #7

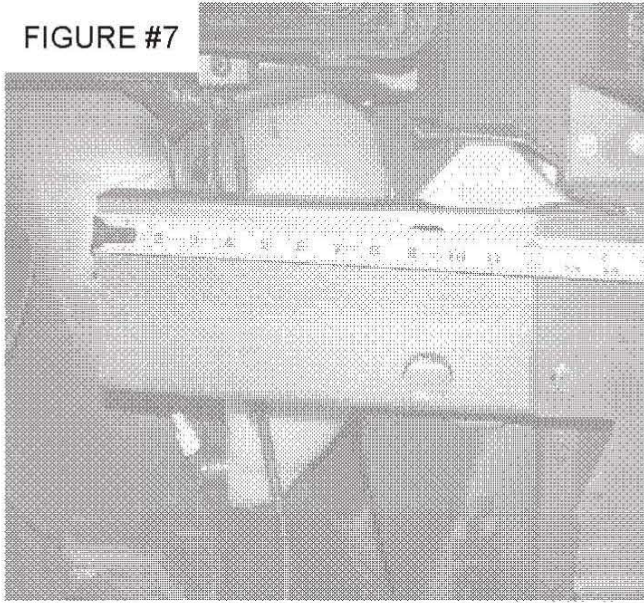

**STEP #5:** Attach the inner upper mounting brackets to the top of the inner mounting brackets installed in STEP #3. There are different sides for driver and passenger. Hold in place with two 3/8" x 1" bolts and winglock nuts. Adjust the bracket so the top of the bracket is 3" off the top of the inner bumper (Installers note: If you do not set the height properly the brackets will not go through the grille as they should. Since these brackets need to be tight before the fascia is returned to the vehicle, accurate measurements are vital. The outer edge of the brackets needs to be 29 1/4" apart. Adjust as needed. Figure #8 shows the passenger side inner and inner upper bracket installed properly.

### SECTION #3 REINSTALL THE FASCIA

**NOTE:** If you are installing the Setina Bodyguard PB5 Fender Protector on this vehicle, you should follow the instructions at this time for installing the inner brackets before reinstalling the fascia.

FIGURE #8

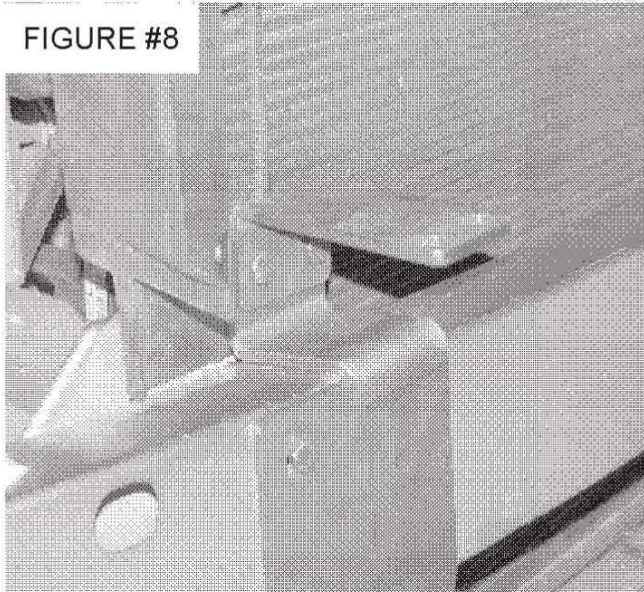

**STEP #1:** Notch the inner plastic webbing. Hold the webbing back up to the bumper and mark where it meets the inner mounting brackets. Notch the bottom of the webbing to accommodate the mounting brackets and the webbing sits flush when the fascia is reinstalled.

**STEP #2:** Check fit by returning the fascia to the vehicle. The inner mounting brackets tab should protrude through the grille on the top and the lower air dam opening on the bottom. See Figure #10. If it does not fit, remove the fascia and adjust the upper bracket up or down as needed.

FIGURE #9

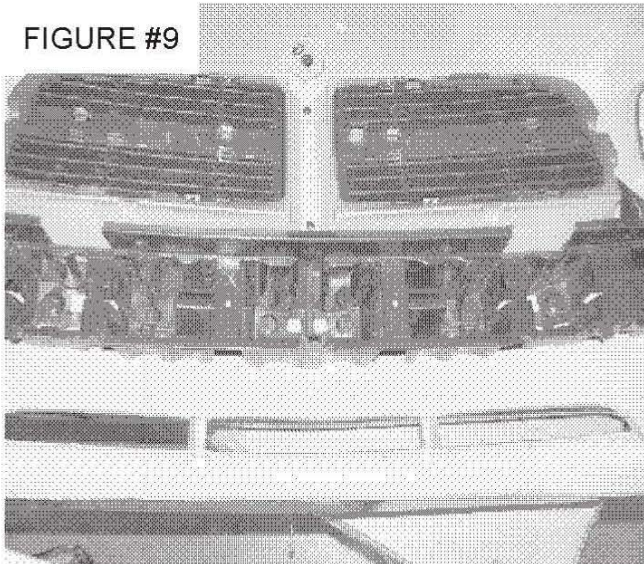

**STEP #3:** Once proper fit is achieved. Reattach the light bulbs to the driving lights (if equipped) Feed the side marker lights back through the headlight openings in the grille and then slide the fascia back in place. There are alignment pins and studs to assist with proper installation. Once the fascia is back in its proper spot. Begin by reinstalling two black plastic plugs on top of the fascia (removed in STEP #2) to hold it in place while you attach the other bolts. When the fascia is attached, reinstall the marker lights.



FIGURE #10

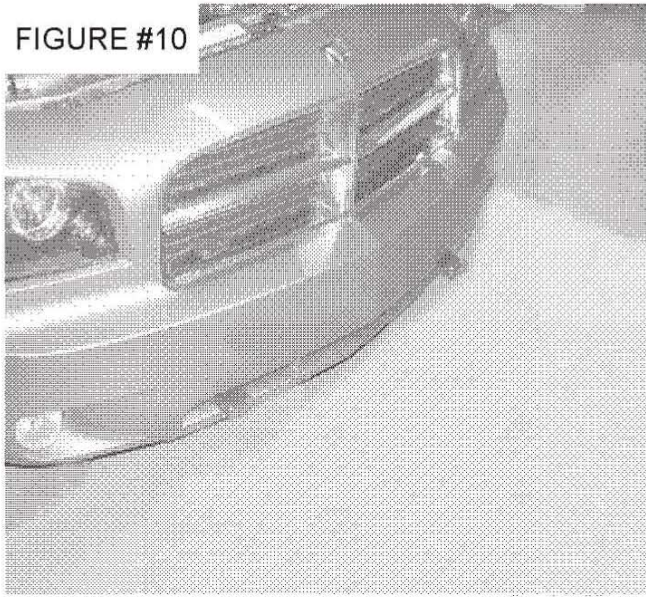

FIGURE #10

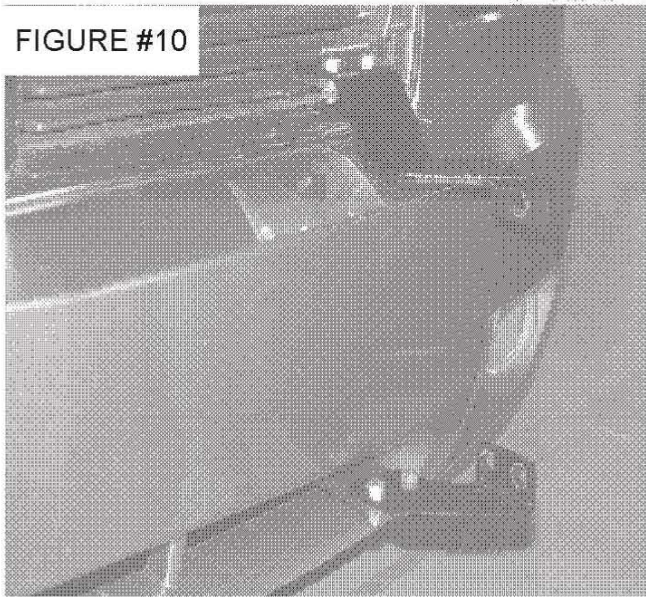
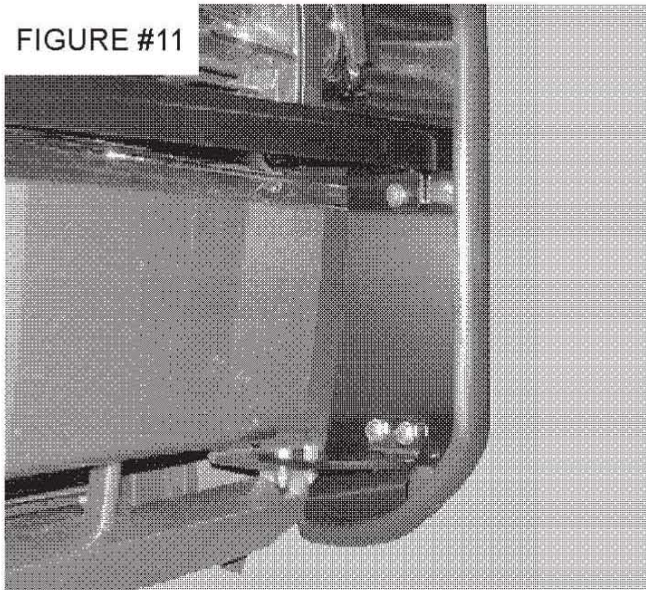

FIGURE #11



**STEP #4:** Reinstall the nuts to the studs inside the fender first, then the bolts (removed in STEP #3). Then the bolts in the fenders (removed in STEP #3) then install the eight bolts on the bottom (Installers Note: Be careful not to overtighten these lower bolts or you will strip them out). Once all the bolts are in place, replace the remaining black plastic plugs on the top of the fascia and the fender wells. Once all the fasteners are back in place, snap the side marker lights back into their recesses.

## SECTION #4 COMPLETING THE INSTALLATION

**STEP #1:** Attach the Upper Outer Mounting brackets to the top of the inner bracket (where it comes through the grille). The side flanges should be pointing down and toward the outside of the vehicle as shown in Figure #11. Use 3/8" x 1" bolts and wizlock nuts, finger tight for now to allow for adjustment later.

**STEP #2:** Attach the Lower Outer Mounting bracket to the top of the lower flange (where it comes out of the air dam). The side flanges should be pointing up and toward the outside of the vehicle. Use 3/8" x 1" bolts and wizlock nuts, finger tight for now to allow for adjustment later.

**STEP #3:** Lift the bumper assembly up to the brackets. Align the holes in the sideplates with the ones on the upper and lower mounting brackets. Use 3/8" x 1" TORX head bolts and wizlock nuts to hold in place, finger tight for now to allow for adjustment later. See Figure #11

**STEP #4:** Adjust the bumper so its pushing surface is perpendicular to the ground and there is an even gap between the back of the sideplates and the vehicles bumper. Tighten all the remaining bolts to secure in place.



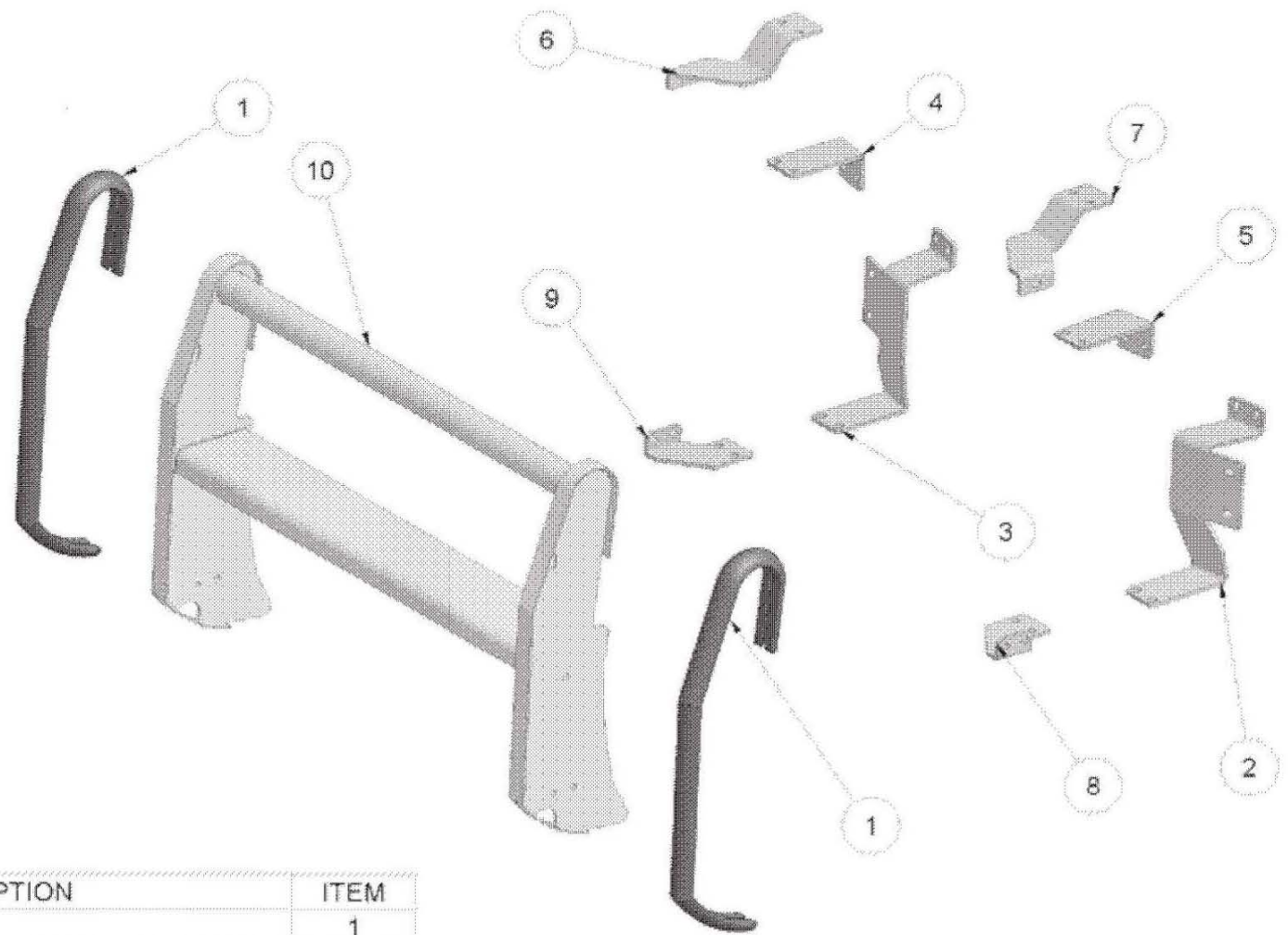

QTY	DESCRIPTION	ITEM
2	Rubber Pad	1
1	Bolt Bag	BB
1	Inner Mounting Bracket - Driver Side	2
1	Inner Mounting Bracket - Passenger Side	3
1	Upper Inner Mounting Bracket - Drivers Side	4
1	Upper Inner Mounting Bracket - Passenger Side	5
1	Upper Outer Mounting Bracket - Drivers Side	6
1	Upper Outer Mounting Bracket - Passenger Side	7
1	Outer Lower Mounting Bracket - Driver Side	8
1	Outer Lower Mounting Bracket - Passenger Side	9
1	Bumper Assembly	10

Bolt Bag Content	
QTY	DESCRIPTION
4	Crush Tubes
4	M8 x 95 Bolt
6	Black Plugs
6	3/8" x 1" Bolt
12	3/8" x 1" Bolt
18	3/8" Wizlock