

PARTS LIST:

1	Grille Guard	2	12mm x 35mm Bolt Plates
1	Driver/Left Frame Mounting Bracket	1	12mm ID x 42mm x 42mm x 5.75mm Square Washer
1	Passenger/Right Frame Mounting Bracket	2	3/8-16" x 1-1/4" Quick Release Bolts
1	Driver/Left Top Bracket	4	12mm Plastic Washers
1	Passenger/Right Top Bracket	4	3/8" x 1-1/4" Plastic Washers
1	Driver/Left Top Support Bracket	10	12-1.75mm x 35mm Hex Bolts
1	Passenger/Right Top Support Bracket	12	12mm x 32mm OD x 3mm Flat Washers
1	Driver/Left Top Support Brace	12	12mm Lock Washers
1	Passenger/Right Top Support Brace	2	12mm Hex Nuts
1	50mm x 75mm x 1.0mm Adhesive Foam Tape	4	3/8" x 1-1/4" OD Flat Washers
2	12mm Double Nut Plates	2	3/8-16" Nylon Lock Nuts

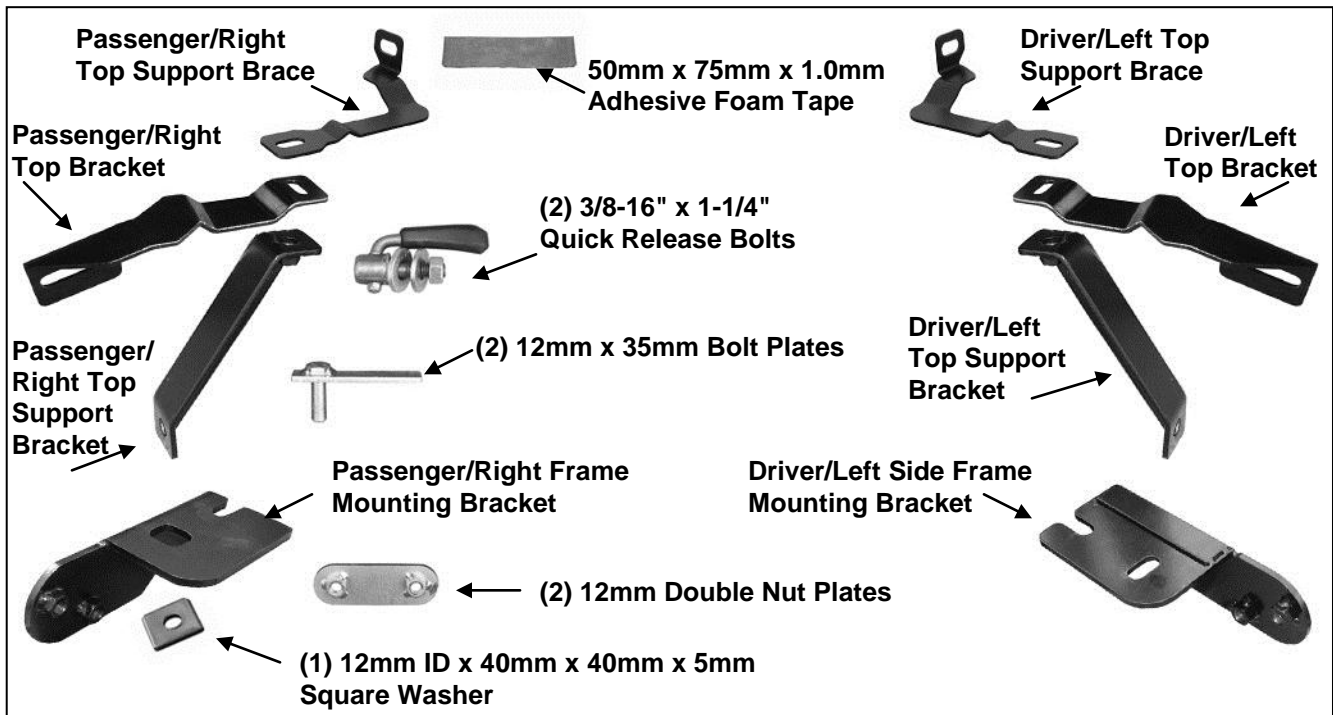

PROCEDURE:

1. REMOVE CONTENTS FROM BOX. VERIFY ALL PARTS ARE PRESENT. READ INSTRUCTIONS CAREFULLY BEFORE STARTING INSTALLATION. ASSISTANCE IS RECOMMENDED. CUTTING MAY BE REQUIRED (VEHICLES WITHOUT TOW HOOKS). LICENSE PLATE MUST BE RELOCATED ON VEHICLES EQUIPPED WITH ECOBOOST.
2. **WARNING!** This Grille Guard is designed to swivel forward by partially loosening the Top Bracket Quick Release Bolts and the upper bolts on the Frame Mounting Brackets when the hood needs to be opened for service. Make sure that all hardware is fully tightened after closing the hood. **Read Page 7, "Opening and closing of hood,"** before installing the Grille Guard. **NOTE:** It may be necessary to remove/relocate the front license plate and license plate bracket. It is not required, but strongly recommended. If local/state law requires a license plate, a license plate relocation kit is available.
3. Determine if the vehicle is or is not equipped with factory tow hooks.

Installation on vehicles without Tow Hooks:

- a. On some vehicles, it may be necessary to remove the lower plastic portion of the bumper to gain access to the ends of the frame rails, (**Figure 1**). An opening in the lower bumper cover will need to be cut out, (if closed), to allow the Mounting Brackets to pass through. Do not trim the

plastic cover until after the Lower Mounting Brackets have been installed and properly aligned on the vehicle, (See **Step 12a** for instructions). Insert the 12mm Double Nut Plate through the opening in the front of the frame, (driver and passenger side). Line up the threaded holes with the two holes in the bottom of the frame, (**Figures 2A & 2B**).

- b. Driver side Frame Bracket installation:** Bolt the Frame Bracket to the Double Nut Plate with the supplied (2) 12mm x 35mm Hex Bolts, (2) 12mm Flat Washers and (2) 12mm Lock Washers, (**Figure 4**). Snug but do not tighten the hardware at this time.
- c. Passenger side Frame Bracket installation:** In the rearmost location, bolt the Frame Bracket to the Double Nut Plate with the supplied (1) 12mm x 35mm Hex Bolt, (1) 12mm Flat Washer and (1) 12mm Lock Washer. In the forward location, use (1) 12mm x 35mm Hex Bolt, (1) 12mm Lock Washer and (1) Square Spacer Plate to cover the large opening in the Mounting Bracket, (**Figures 5A & 5B**). Snug but do not tighten the hardware at this time.
- d.** Do not reinstall the plastic lower bumper cover at this time if removed, (See **Step 12a**).

Installation on vehicles with Factory Tow Hooks:

- a.** Remove the factory tow hooks, (**Figure 3**). **NOTE:** This Grille Guard is not compatible with the factory tow hooks and they will not be reinstalled.

Driver side Frame Bracket installation: Repeat **Step 3b**, (see above).

Passenger side Frame Bracket installation: Repeat **Step 3c**, (see above).

- 4.** Move the driver side and passenger side Frame Mounting Brackets in as far as possible, (loosen hardware slightly if necessary).
- 5.** Next, open the hood on the vehicle and locate the top of the bumper bracket. Locate the open outer hole in the bracket, (**Figure 6**). Insert (1) 12mm x 35mm Bolt Plate into the gap at the top of the bracket and out through the hole with the threaded end facing to the rear (**Figures 7A & 7B**). Place the driver side Top Support Bracket over the threaded end of the Bolt Plate and secure with (1) 12mm Flat Washer, (1) 12mm Lock Washer and (1) 12mm Hex Nut, (**Figure 8**). Snug but do not tighten hardware.
- 6.** Cover the top of the plastic bumper with removable tape, (masking tape), during installation, (**Figure 10**). Also place a piece of Foam Tape on the bottom of both Top Brackets any place that the Bracket may come in contact with the plastic bumper to prevent damage to the painted finish on the vehicle
- 7.** Select the driver side Top Support Brace. Remove the factory hex bolt in the radiator mount. Bolt the Support Brace in place with the factory hex bolt, (**Figure 9**). Leave loose at this time. Select the driver side Top Bracket and insert it between the Support Bracket and the Rear Brace. Line up the holes in the (3) Brackets and bolt together with (1) 12mm x 35mm Hex Bolt, (1) 12mm Flat Washer and (1) 12mm Lock Washer, (**Figure 10**). Do not tighten hardware at this time.
- 8.** Repeat **Steps 5 - 7** for passenger side Top Bracket, Support Bracket and Brace installation.
- 9.** With help, place the Grille Guard face down on a clean surface in front of the vehicle, (**Figure 11**). Position the mounting tabs on the Grille Guard up to the outside of the Mounting Brackets. Line up the lower holes in the Frame Mounting Brackets with the holes in the Grille Guard. Insert (1) 12mm Plastic Washer between the Mounting Bracket and the Grille Guard on both Brackets and bolt together with the included (2) 12mm x 35mm Hex Bolts, (2) 12mm Lock Washers, (4) 12mm Flat Washers and (3) 12mm Hex Nuts, (**Figure 12**). Snug but do not tighten hardware at this time.
- 10.** With assistance, use the two previously installed Hex Bolts as a hinge and rotate the Grille Guard up to the vehicle, (**Figure 11**). Line up the remaining holes in the Brackets with the holes in the Grille Guard. Insert a 12mm Plastic Washer between the Mounting Bracket and the Grille Guard on both sides of the vehicle as described in **Step 9**. Bolt the Brackets together with (2) 12mm x 35mm Hex Bolts, (2) 12mm Lock Washers, (4) 12mm Flat Washers and (2) 12mm Hex Nuts. Do not tighten hardware at this time.
- 11.** Next, line up the slotted hole in the Top Bracket with the hole in the Grille Guard upright. Insert (1) 3/8" Plastic Washer between the Top Bracket and the Grille Guard, (**Figure 13**). Line up the hole in the Plastic Washer with the hole in the Grille Guard and the slot in the Top Bracket. Insert (1) 3/8" Quick Release Bolt and (1) 3/8" Flat Washer through the Grille Guard, Plastic Washer and Top Bracket. Secure the Quick Release Bolt with (1) 3/8" Plastic Washer, (to protect the finish on the Top Bracket), (1) 3/8" Flat Washer and (1) 3/8" Nylon Lock Nut, (**Figures 14A & 14B**). Snug but do not tighten at this time. Repeat this step for the passenger side Quick Release installation.
- 12.** With the hood open, push the Grille Guard back until it is vertical. Align, center and adjust the Grille Guard properly and tighten all Mounting Bracket and Support Bracket hardware.

**GRILLE GUARD
2009-013 F-150**

- a. **On vehicles without tow hooks:** Temporarily remove the Grille Guard. Hold the plastic lower bumper cover up in approximate position against the bottom of the bumper, (If cover was previously removed in **Step 3a**). Mark the Bracket location onto the back of the bumper cover. Cut slots through the cover to clear the Brackets, (**Figure 15**). **IMPORTANT:** For best results, start with a small opening and only trim away material required for Bracket clearance. Once properly trimmed, reinstall plastic bumper cover with factory hardware.
 - b. Reinstall the Grille Guard.
13. Release the levers on the Quick Release Bolts, (**Figure 16A**), and loosen the top Hex Bolts on the Frame Mounting Bracket. **WARNING!** Do not loosen the bolts all the way. Loosen hardware only enough to move the Grille Guard. Damage to the truck or Grille Guard may occur.
 14. Pull the Grille Guard forward, away from the vehicle, (**Figure 17**).
 15. Carefully close the hood and check for clearance between the Top Bracket and the factory grille. Adjust the Brackets for fit as necessary. **IMPORTANT:** Always make sure that the hood and grill will clear the Grille Guard before closing the hood.
 16. Push the Grille Guard back towards the vehicle until it is vertical, check the alignment again and adjust the Grille Guard as required. Tighten all Mounting Bracket hardware including the Quick Release Bolts, (**Figure 16B**).
 17. Do periodic inspections to the installation to make sure that all hardware is secure and tight.

To protect your investment, wax this product after installing. Regular waxing is recommended to add a protective layer over the finish. Do not use any type of polish or wax that may contain abrasives that could damage the finish.

For stainless steel: Aluminum polish may be used to polish small scratches and scuffs on the finish. Mild soap may be used also to clean the Grille Guard.

For gloss black finishes: Mild soap may be used to clean the Grille Guard.

Driver Side Installation Pictured



(Fig 1) Lower bumper cover for vehicles without tow hooks pictured

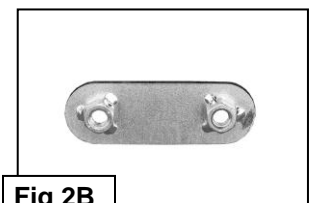
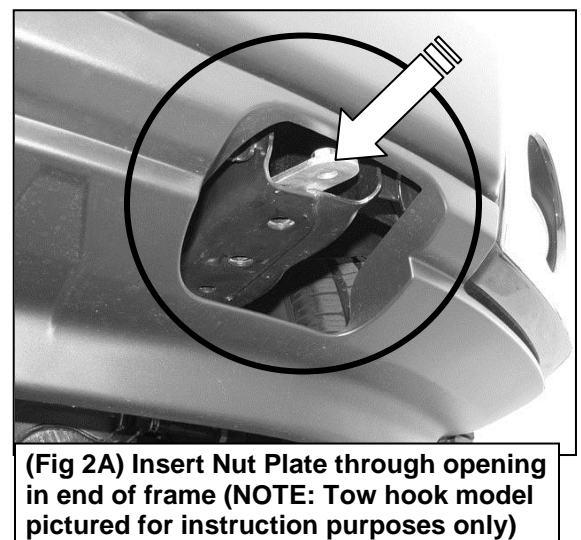

Fig 2B



(Fig 2A) Insert Nut Plate through opening in end of frame (NOTE: Tow hook model pictured for instruction purposes only)

Driver Side Installation Pictured

Remove tow hooks if equipped

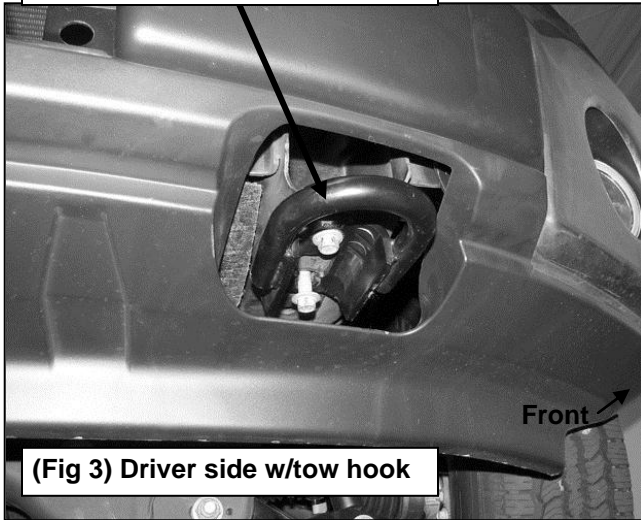

(Fig 2) Use the factory tow hook hardware or:
(1) 12mm Double Nut Plate
(2) 12mm x 35mm Hex Bolts
(2) 12mm Lock Washers
(2) 12mm Flat Washers



IMPORTANT: The passenger side Frame Mounting Bracket is provided with more adjustability to compensate for various model years and frame configurations. The Bracket requires the Square Spacer for proper installation

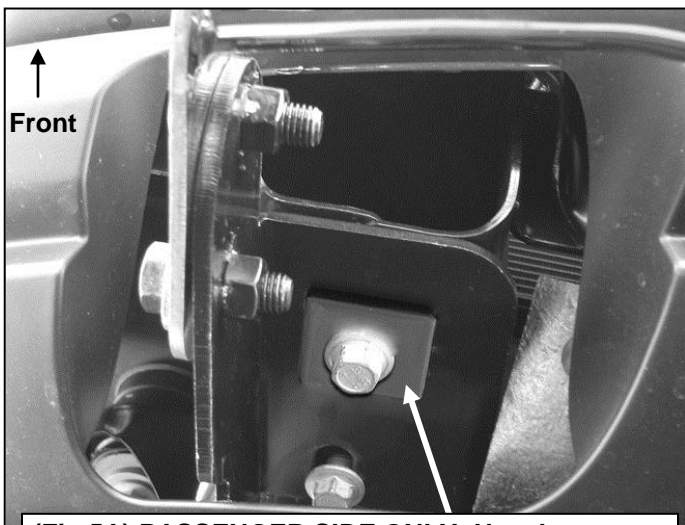
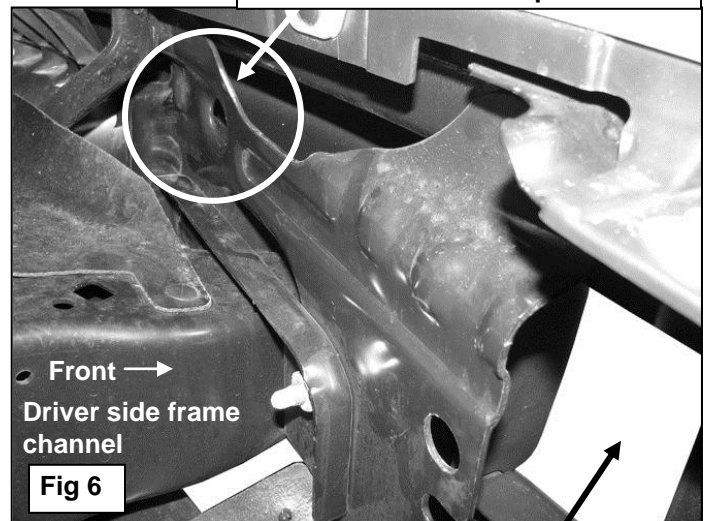

Fig 5B

Insert 12mm Bolt Plate through outermost hole in bumper bracket



Opening in center of bumper

Driver Side Installation Pictured

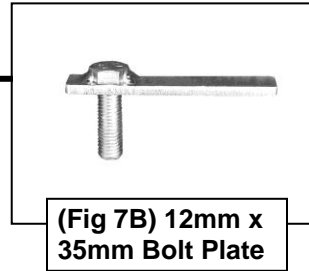
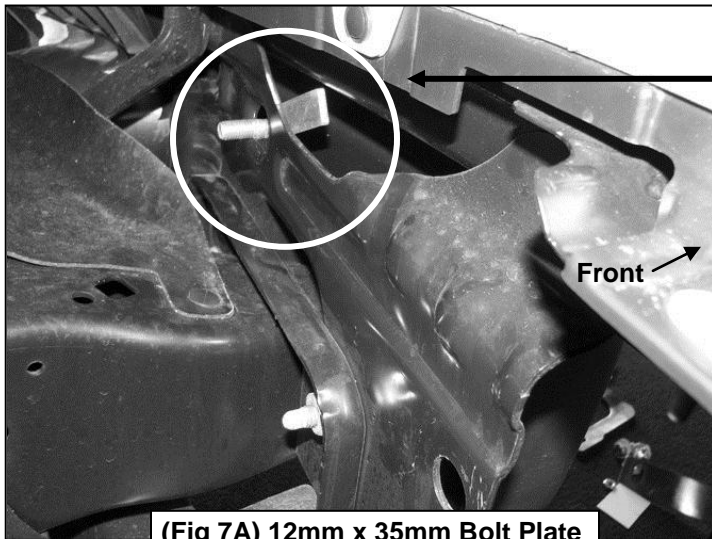

Cover a section (dotted line) of the top of the bumper with removable tape to prevent damage to finish on bumper

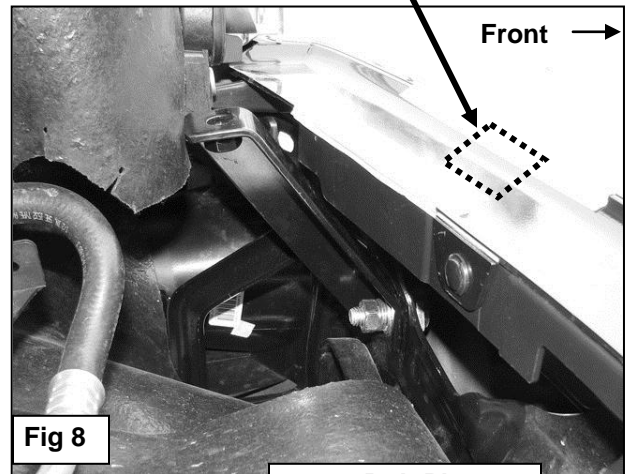

12mm Bolt Plate
12mm Lock Washer
12mm Flat Washer
12mm Hex Nut

Use factory hex bolt

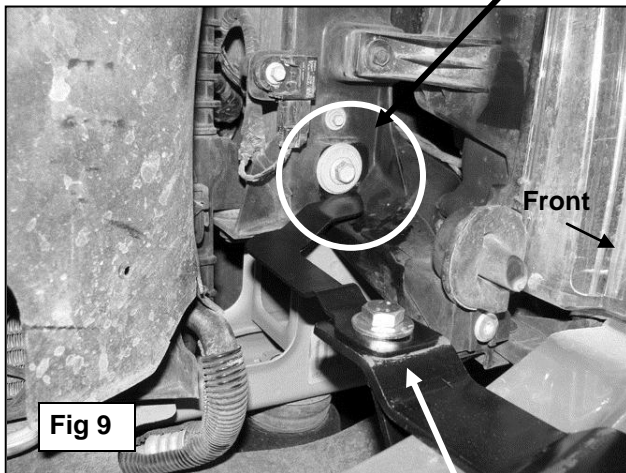

12mm x 35mm Hex Bolt
12mm Lock Washer
12mm Flat Washer

Cover a section (dotted line) of the bottom of the Bracket with Foam Tape to prevent damage to finish on bumper

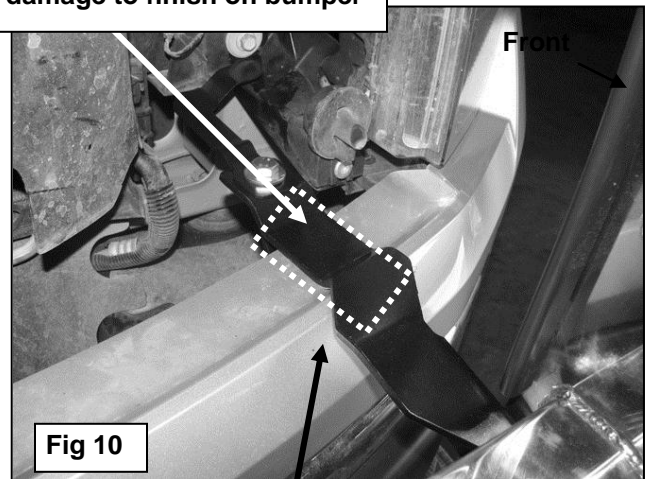

Protect the top of the plastic bumper cover with masking tape to prevent scratches during installation

Driver Side Installation Pictured



For easier installation, insert (1) 12mm Hex Bolt per side in the location pictured in Figure 8 to act as a hinge. Snug the hardware but do not tighten, then rotate the Grille Guard up into position

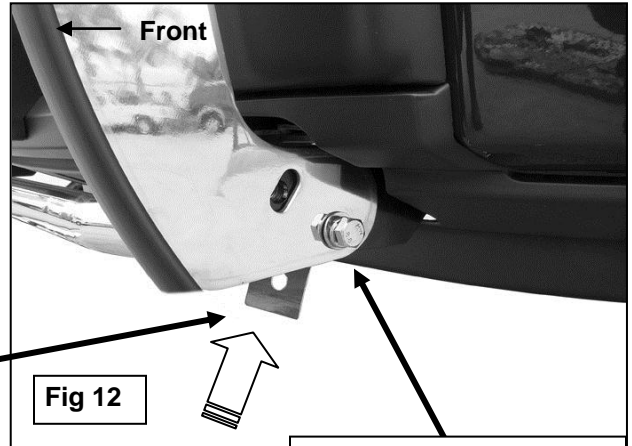

Insert 12mm Plastic Washers between the Grille Guard and the Mounting Bracket. Line up the holes in the Plastic Washers with the mounting holes. Insert the Mounting Bolts through the Plastic Washers

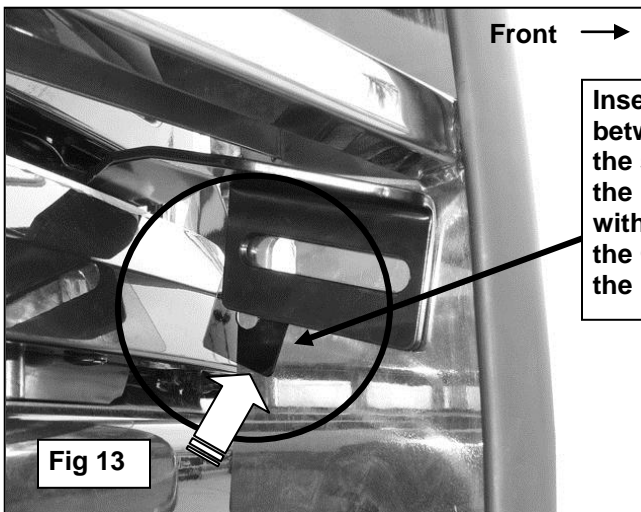

Insert a 3/8" Plastic Washer between the Grille Guard and the slotted Top Bracket. Line up the hole in the Plastic Washer with the mounting holes. Insert the Quick Release Bolt through the Plastic Washers

- 12mm x 35mm Hex Bolt
- 12mm Lock Washer
- (2) 12mm Flat Washers
- 12mm Hex Nut
- 12mm Plastic Washer

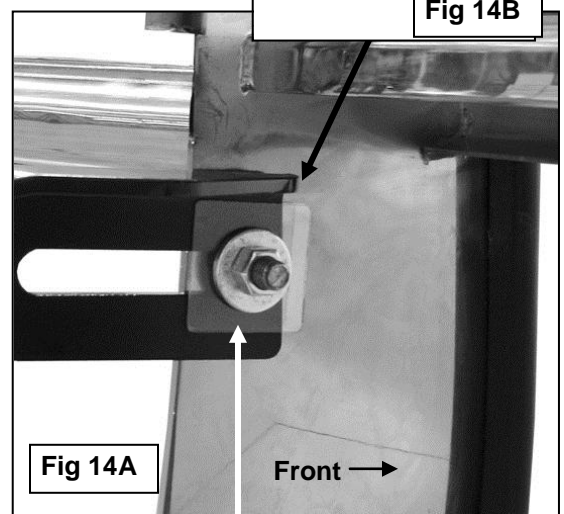
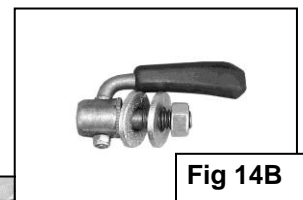

Place a 3/8" Plastic Washer between the slotted Top Bracket and the 3/8" Flat Washer to protect the finish on the Top Support Bracket

(Fig 15) Cut area pictured for example only. Installer responsible for correct modifications

Driver Side Installation Pictured

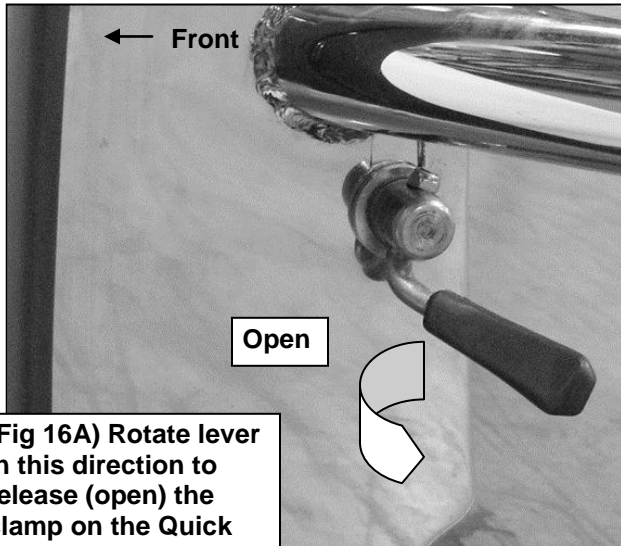

(Fig 16A) Rotate lever in this direction to release (open) the clamp on the Quick Release Bolt

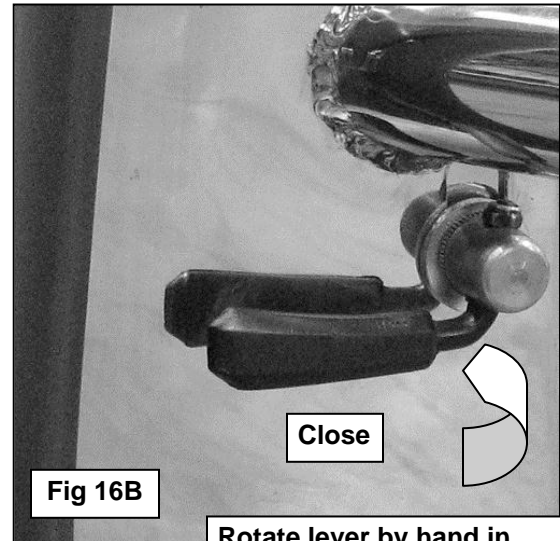

Fig 16B

Rotate lever by hand in opposite direction to close the clamp on the Quick Release Bolt. Tighten or loosen the 3/8" Nylon Lock Nut to adjust the clamping pressure on the Quick Release Bolt. When properly adjusted, it should require reasonable force (by hand) to completely close the lever

To open the hood, release the lever on the Quick Release Bolts. Try to pull the Grille Guard forward. If Necessary, loosen the Hex Bolts securing the Grille Guard to the Mounting Brackets. Only loosen the hardware enough to move the Grille Guard



Fig 17

(2) 12mm x 35mm Hex Bolts
(2) 12mm Lock Washers
(4) 12mm Flat Washers
(2) 12mm Hex Nuts
(2) 12mm Plastic Washers

Opening and closing the hood

1. Rotate the levers on the two Quick Release Bolts 1/2 turn to loosen the clamp on the Top Bracket, **(Figure 16A)**. Try to pull the Grill Guard forward. If necessary, slightly loosen the top hex bolts on the Frame Mounting Brackets to pivot the Grille Guard away from the vehicle. Carefully pull on the Grille Guard until it is fully extended away from the vehicle, **(Figure 17)**. **WARNING!** Do not loosen the bolts all the way. Damage to the truck or Grille Guard may occur. Only loosen the bolts enough to move the Grille Guard.
2. Pull the hood release and open the hood.
3. **IMPORTANT:** Before closing the hood, always check to make sure that the Grille Guard hasn't been pushed back to its "closed" position and that it is fully extended away from the vehicle, then close the hood.
4. Once the hood is completely closed, push the Grille Guard back to its closed, upright position and tighten all hardware on the Grille Guard. Rotate the lever on the Quick Release clockwise to tighten, **(Figure 16B)**. No tools are required to close the Quick Release levers. It will require some effort to open and close by hand when properly adjusted.
5. Do periodic inspections to the installation to make sure that all hardware is secure and tight.