



PARTS LIST:

1	Driver/Left Taillight Guard	2	4mm x 8.65mm OD x 0.8mm Flat Washers
1	Passenger/Right Taillight Guard	4	ST6.3 x 25mm Philips Self-Tapping Screws
2	Support Brackets	2	ST3.5 x 12mm Philips Self-Tapping Screws
2	4mm x 12mm Philips Screws	4	8mm x 16mm OD x 1.6mm Flat Washers

PROCEDURE:

- 1. REMOVE CONTENTS FROM BOX. VERIFY ALL PARTS ARE PRESENT. READ INSTRUCTIONS CAREFULLY BEFORE STARTING INSTALLATION. DRILLING IS REQUIRED.**
- Open the rear door and remove the (2) screws holding the driver side taillight assembly to the vehicle, (**Figure 1**). Hold the taillight assembly firmly in both hands and pull straight away from the body to release the assembly from the factory clips. Be sure to pull straight out to avoid possible damage to the assembly. Do not twist or tilt the taillight during removal. **NOTE:** Refer to the owner's manual for more info regarding taillight bulb replacement for taillight removal.
- Disconnect the wiring harness and set the taillight aside. Select the driver side Taillight Guard and (1) Support Bracket. Temporarily bolt the Support Bracket to the Guard with (1) 4mm x 12mm Phillips Screw, (**Figure 2**). Apply a layer of removable tape, (masking tape for example), around the edge of the opening for the taillight assembly. Hold the Taillight Guard in place on the vehicle with the Support Bracket flush against the edge of the body protected by the tape. Bolt the (2) mounting tabs on the Guard to the vehicle with the included (2) ST6.3mm x 25mm Philips Screws and (2) 8mm Flat Washers, (**Figure 3**). Do not tighten hardware at this time.
- Carefully align the guard and Support Bracket to the vehicle. **NOTE:** Mounting Tabs may move during shipping. Tabs can be adjusted to better fit the vehicle using a pair of pliers. Protect the finish on the mounting tabs with a layer of tape when adjusting. Once satisfied with the placement, mark the location of the Support Bracket onto the masking tape covering the edge of the body, (**Step 3**). Drill this location with a 1/16" drill bit, (**Figure 4**). **IMPORTANT:** Any cutting or drilling tool may break or shatter. Government regulations require safety glasses & equipment at all times when cutting or drilling.
- Remove the Support Bracket from the Guard. Attach the Support Bracket to the body with the included (1) ST3.5mm x 12mm Phillips Screw and (1) 4mm Flat Washer, (**Figure 5**). Tighten the screw completely. Do not over tighten hardware or damage to the vehicle may result.
- Plug in the wiring on the taillight assembly and reinstall the taillight.
- Re-install the Taillight Guard onto the vehicle using the hardware listed in **Step 3**.
- Adjust the Taillight Guard properly and tighten all hardware.
- Repeat Steps 2 – 8 for passenger side Taillight Guard installation.
- Do periodic inspections to the installation to make sure that all hardware is secure and tight.

To protect your investment, wax this product after installing. Regular waxing is recommended to add a protective layer over the finish. Do not use any type of polish or wax that may contain abrasives that could damage the finish.

For stainless steel: Aluminum polish may be used to polish small scratches and scuffs on the finish. Mild soap may be used also to clean the Sidebar.

For gloss black finishes: Mild soap may be used to clean the Taillight Guard.

Driver Side Installation Shown

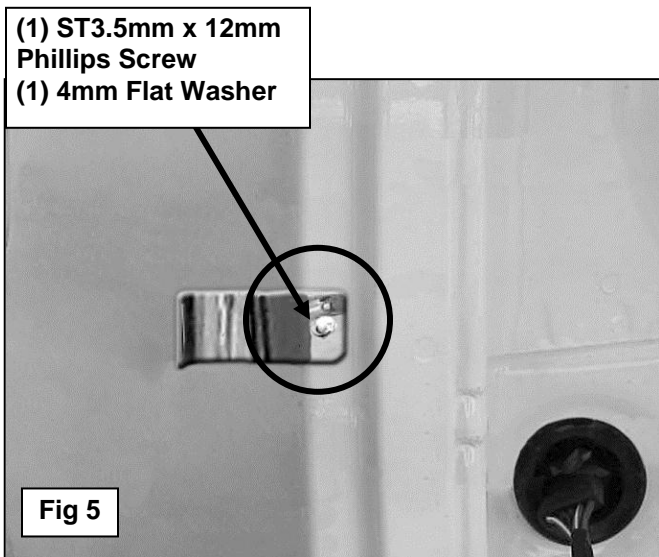
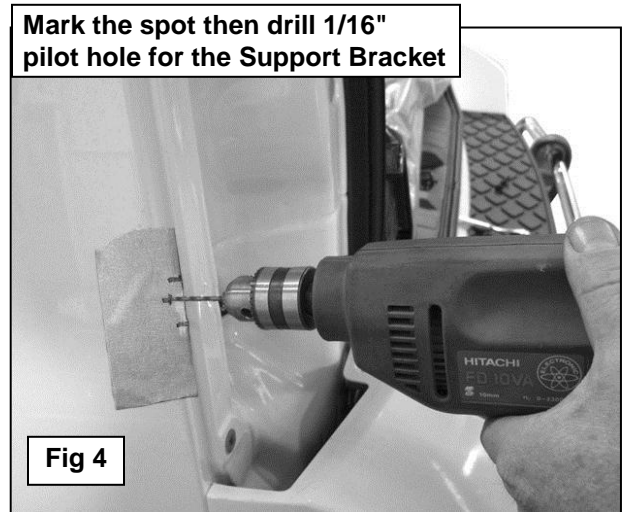
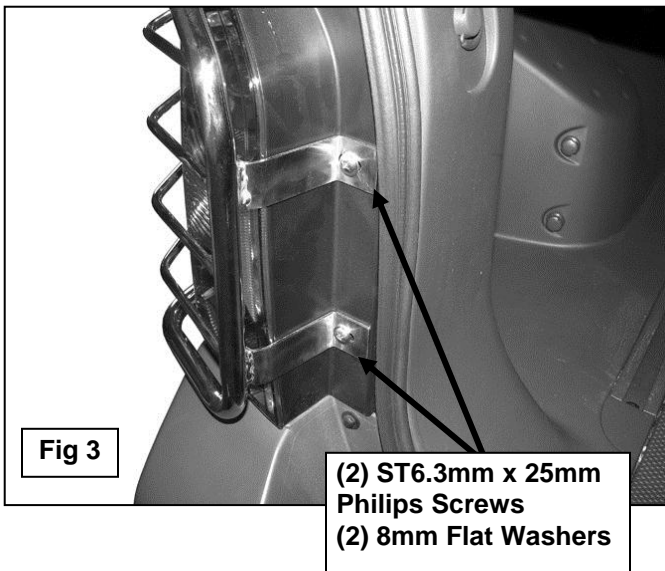
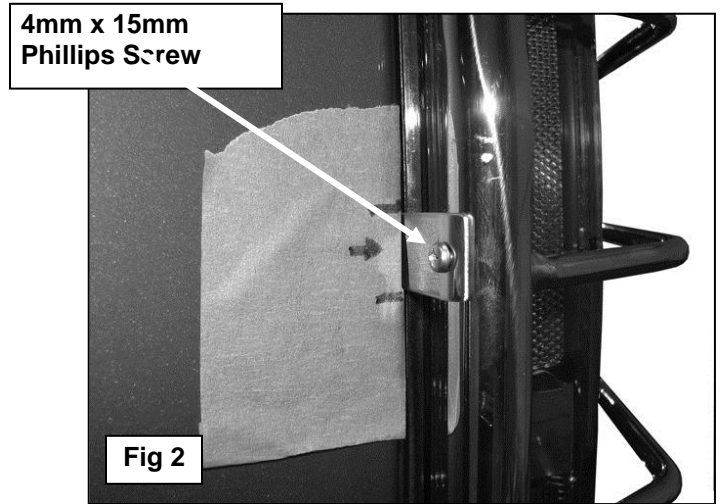
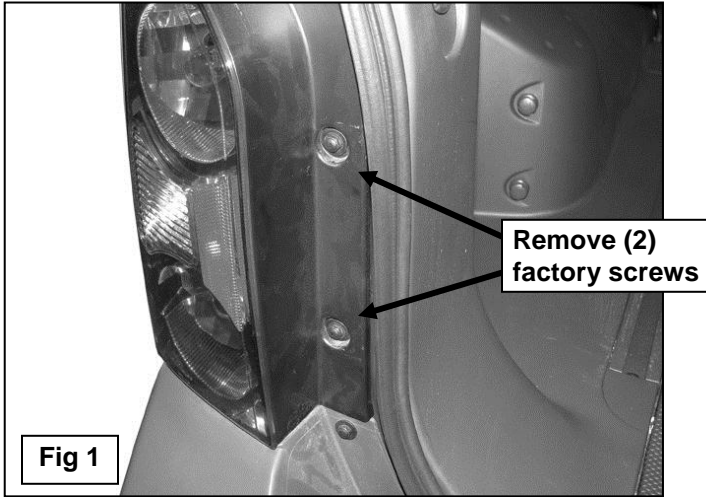

IMPORTANT: Any cutting or drilling tool may break or shatter. Government regulations require safety glasses & equipment at all times when cutting or drilling.

