



S197 Mustang

High Performance Upper Strut Mounts

Installation Instructions for 555-8120 & 555-8121

Note: The installation of these Competition Upper Strut Mounts requires the removal of the factory mounts that have the springs in a preloaded state. The potential energy stored in the springs can be very dangerous if not properly disassembled. Follow the factory service procedures or have this installation performed by a qualified technician. It is recommended that a factory service manual be available when installing these new mounts. The provided grease is used for the urethane bushings only!

1. Follow the factory service procedures and remove the strut and spring assembly.
2. Disassemble the strut and spring assembly. This should be performed using the correct strut/spring clamping device. If you do not have the spring removal equipment, take your strut assemblies to a technician for disassembly. External spring compressors may be used, but is not recommended.

If you have part # 555-8120 for tapered, stock-style springs, perform Steps 3-5. If you have part # 555-8121 from the coilover kit, skip to Step 6.

3. Remove the rubber spring insulator from the stock strut mount **Pics 1&2**

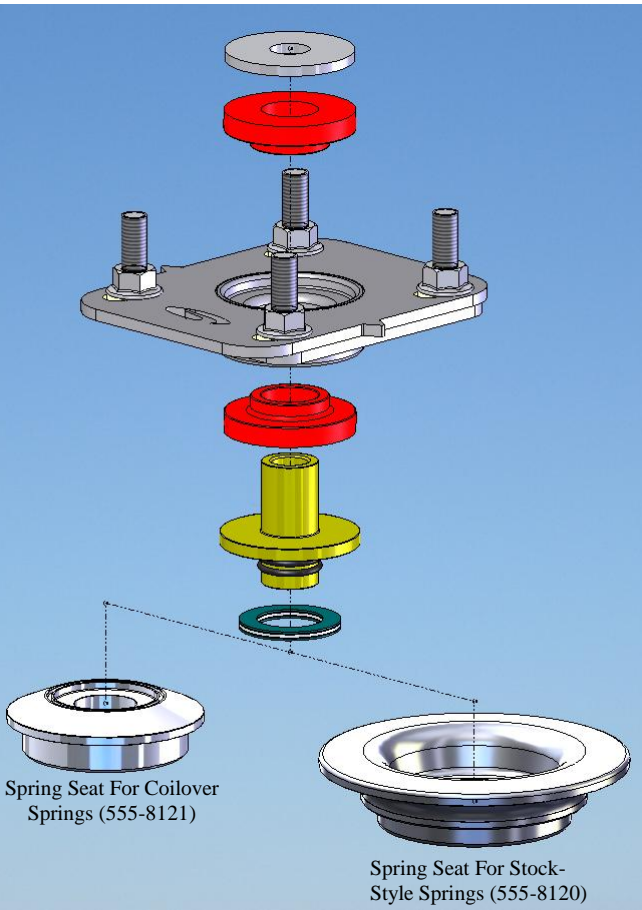

4. Remove the spring seat base from the new assembly. Insert the new spring base into the factory rubber spring seat. Be sure to keep the billet spring seat base face up to prevent disturbing the bearing inside. **Pics 3 & 4**



- Return the seat base to the assembly. **Pic 5**



- Slide the entire assembly over the shaft of the strut **Pic 6** and align the pig tail of the spring with the coil pattern of the spring seat. (only kit 555-8120) **Pic 7**
- Torque the upper strut nut to 46 lb-ft. Take care when tightening the nut so that the assembly stays together as shown above.



- Remove the four upper strut mount nuts from the new assembly. Then align the Steeda logo with the outside of the vehicle.
- Reinstall the strut assembly following the factory installation procedures.
- Repeat steps 1-9 for the opposite side.
- Take a slow test drive and recheck all the fasteners before resuming normal driving.

**Recommended Camber setting for
S197 Mustangs**

Street	-0.7 to -1.0
Aggressive Street	-1.0 to -1.25
Race	-1.25 to -2.5
*Note stock calls for -0.7	