

200A

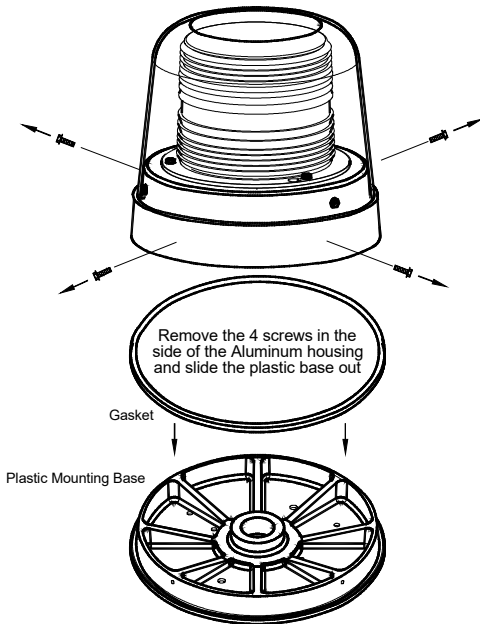

1. Remove the four screws in the side of the aluminum housing.
2. Slide the plastic base out of the aluminum case.
Do not to damage the gasket.

3. Determine which knockouts on the base will work best for your application and clear them using a punch or other appropriate tool.
4. Using the plastic mounting base as a template, mark the appropriate holes on the mounting surface.
5. Drill a 3/8" hole in the marked locations. Then, if applicable, drill a 3/8" hole for the wires in the center of the outer holes.

CAUTION: Take care not to drill through the headliner of the vehicle below.

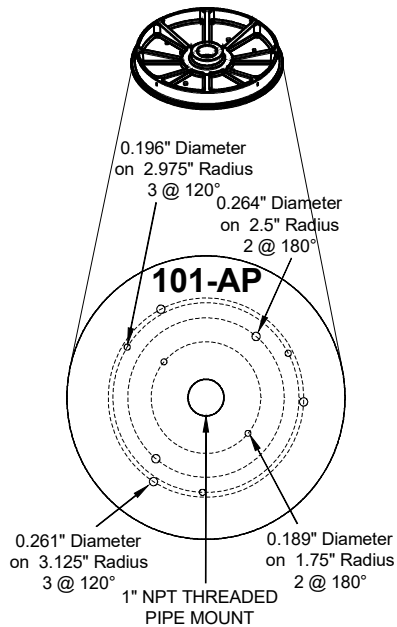

6. Insert the rubber well nuts into the mounting holes so the wider lip rests on the mounting surface.
7. Route the wires through the center hole and install the screws through the base, into the well nuts, and tighten until snug.
8. Place the light on the base and reinstall the four screws.

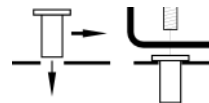

Pipe Mounting

For NPT pipe, mount the light using the threaded entrance hole in the base of the light, then skip to the **Wiring Instructions**.

200S, 240, and 266 Surface Mounting

1. Decide which holes you will be using to mount your light. Models without a flange will have knockouts inside the base that can be used. To locate them, carefully remove either the clamp ring or the screws near the base of the lens and lift off the lens. Use a punch or drill to remove the knock-outs present.
2. Using the gasket as a template, mark the appropriate mounting holes. Mark a center hole if you will be running your wires through the mounting surface.
3. In the marked locations, drill appropriately sized holes for the hardware you are using.
4. If using well nuts, push them through the mounting holes until the bottom side of the wider lip rests on the surface of the vehicle.
5. Install the wire grommet on the center hole (if applicable).
6. Route the wires through the center hole (if applicable) and secure the light with included hardware.

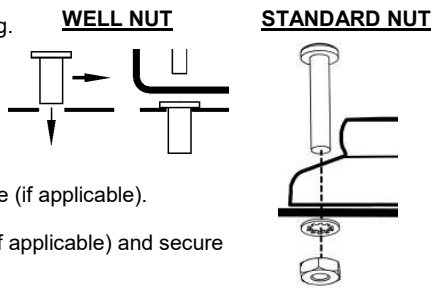

Magnet Mounting

WARNING!!!! Care should be taken when positioning any warning light on the roof, dash, or instrument panel of the vehicle, so that the light and/or cord does not interfere with the proper operation of any airbags! Failure to heed this warning may result in serious or fatal injury.

If you are mounting the light on the roof of your vehicle, take extreme care to ensure that the magnet is firmly seated on your roof, and that the pull of the magnet is sufficient to secure the light in place. As the composition of the metal in the roofs of different vehicles may vary, as well as the contour, texture, and/or condition, the manufacturer cannot guarantee the ability of the light to remain in place upon a moving vehicle. It is the sole responsibility of the owner to ensure the warning light is secure.

- **CAUTION:** Please be sure to check that your cigarette plug outlet is properly fused. **Testing the light before this fuse is properly installed will void the warranty on the light.**
- If the light fails to work when the plug is inserted into the cigarette plug socket, twist the plug a few times to remove any ash or other deposits which might be preventing a good contact from being made. If the problem persists, check for a fuse inside of the plug itself. If present, remove the fuse from the circuit, check to see if it has blown, and clean the lighter socket and contact surfaces. Reconnect the fuse and test the light again.

Wiring Instructions

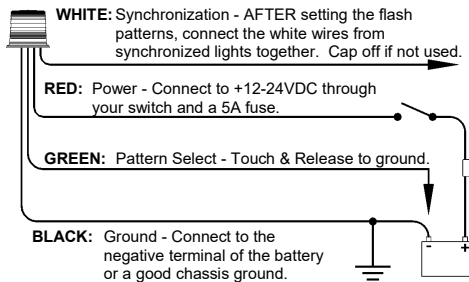

CAUTION:
All of our DC powered warning lights are polarity sensitive. These lights are polarity protected *only if the appropriate fuse is used*. All wires connected to the positive terminal of the battery should be fused at the battery for their rated load. **Testing the light before this fuse is properly installed will void the warranty on the light.**

⚠ Cig Plug Models : +12VDC only

Please Note: If your light contains a **PURPLE** wire, it is a dead wire that is not used and can be cut short.

Pattern Programming

To change patterns, press the pattern select button on the cig plug, or touch the **green wire** to ground on hard-wired models.

If applicable, after the pattern has been set, tape or place a wirenut over the end of the green wire to prevent it from coming into contact with ground.



SYNCHRONIZATION

(Hard wire only)

You can synchronize up to six lights with **LINK SYSTEM** compatibility.

DO NOT CONNECT WHITE WIRES UNTIL PROGRAMMING HAS BEEN COMPLETED FOR ALL LIGHTS!!

Alternating Pattern (Programmed for opposite Phases)

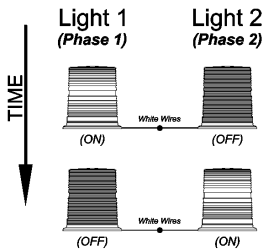

Simultaneous Pattern (Programmed for same Phase)

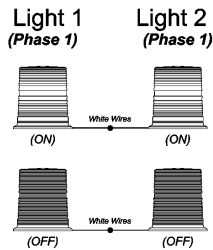

1. Program the first unit.
2. Program the second light with the same **Pattern Type**.
Lights with the **SAME** phase flash together (simultaneous).
Lights with **DIFFERENT** phases flash opposite one another (alternate).
3. After programming all lights, cap off the green wires and with the power off, connect the white wires together.
4. Test lights by applying power to all of them at the same time.

Phase 1 Flash Pattern	Phase 2 Flash Pattern	Pattern Type	Pattern Description	Shortcuts
1	13	K	Flicker †	Pattern 1 (Phase 1): 3 sec or 1 flash Pattern 13 (Phase 2): 9 sec or 3 flashes
2	14	L	Fast Doubleflash	
3	15	M	Tripleflash †	
4	16	N	ECE Quadflash †	Pattern 4 (Phase 1): 6 sec or 2 flash
5	17	O	ECE Doubleflash †	
6	18	F	Quadflash †	Pattern 16 (Phase 2): 12 sec or 4 flashes
7	19	G	Quadflash w/Post-Pop †	
8	20	H	Singleflash †	
9	21	I	Doubleflash †	
10	22	J	Variable AKA Delta-Omega	
11	23	C	Post pop 1.4CPS †	
12	24	E	Random 0.4CPS	18 Sec/5 Blinks
	NA		Steady	

† - SAE J845 approved patterns when properly configured
Pattern Shortcuts: Hold Green wire to ground for indicated time.
Steady Burn: Not in Pattern Cycle. Hold Green wire to ground for 18 seconds (light will flash 5 times).