

MANUAL

Halo™ LED Lights 200, 240, 242, 250, 255, 257, and 258 Series

featuring the

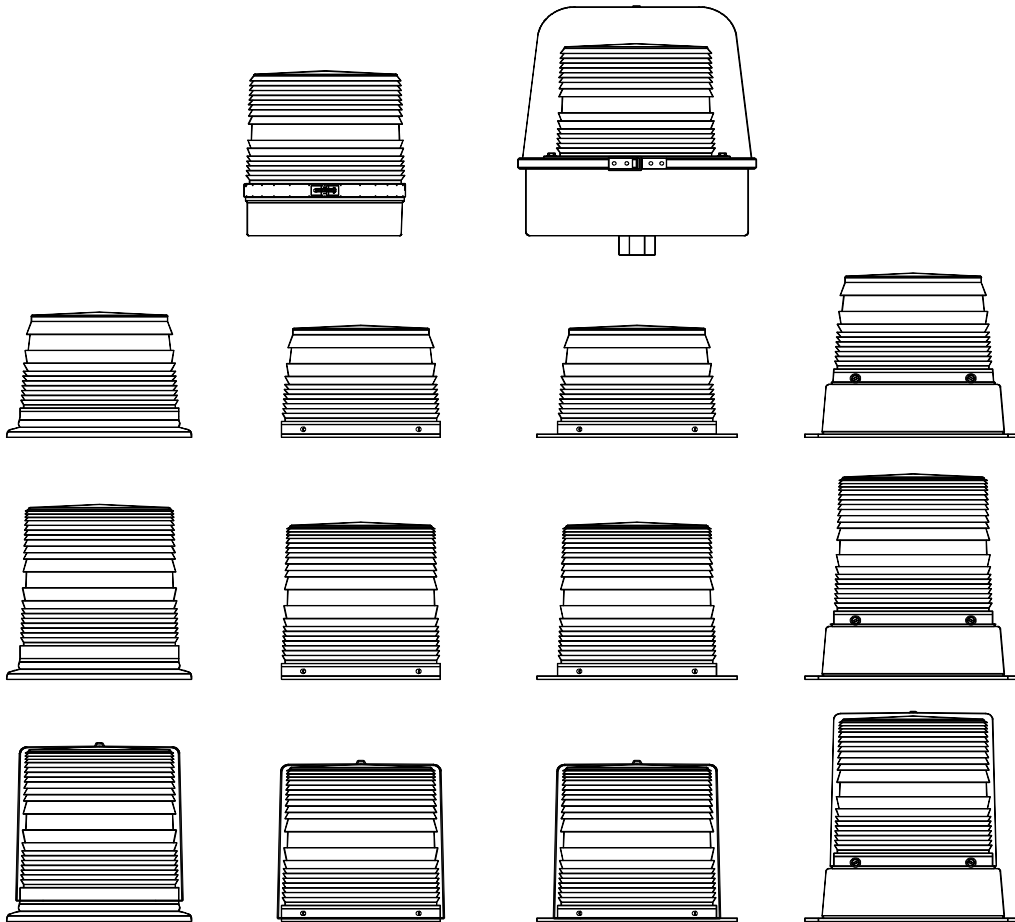

 **WARNING!** These lights utilize high-intensity LEDs. Do not stare directly into the light while it is on, as momentary blindness and/or permanent eye damage may occur.

Magnet Mounting

If you are mounting the light on the roof of your vehicle, take extreme care to ensure that the magnet is firmly seated on your roof, and that the pull of the magnet is sufficient to secure the light in place. As the composition of the metal in the roofs of different vehicles may vary, as well as the contour, texture and/or condition, Star cannot guarantee the ability of the light to remain in place upon a moving vehicle. It is the sole responsibility of the owner to ensure the warning light is secure.

WARNING!!!! Care should be taken when positioning any warning light on the roof, dash, or instrument panel of the vehicle, so that the light and/or cord does not interfere with the proper operation of any airbags! Failure to heed this warning may result in serious or fatal injury.

- **CAUTION:** Please be sure to check that your cigarette plug outlet is properly fused. **Testing the light before this fuse is properly installed will void the warranty on the light.**
- Once the light is secured, route your cord such that it does not interfere with the vision of the driver or the operation of any controls, including, but not limited to, the steering wheel, gear shifter, and/or airbag.
- This light has been factory tested and approved. If the light fails to work when the plug is inserted into the cigarette plug socket, twist the plug a few times to remove any ash or other deposits which might be preventing a good contact from being made. If the problem persists, check for a fuse inside of the plug itself. If present, remove the fuse from the circuit, check to see if it has blown, and clean the lighter socket and contact surfaces. Reconnect the fuse and test the light again.

Permanent Mounting

1. For NPT pipe, mount the light using the threaded entrance hole in the base of the light, then skip to the **Wiring Instructions**.
 - If you will be utilizing a **flange mount base**, proceed to Step 2.
2. Using the gasket as a template, mark the mounting holes. Be sure to mark the center hole if you will be running your wires through the mounting surface.
3. Remove the gasket and drill your holes using an appropriate 3/8" drill bit.
CAUTION: If you are mounting the light on a vehicle, and plan to wire it through the roof of the vehicle, remove the headliner from the inside of the vehicle. If you do not remove the headliner, take care so that you do not drill through it.
4. Push the enclosed rubber well nuts through the outer holes until the bottom side of the wider lip rests on the surface of the vehicle.
5. Route the wires through the center hole, if applicable and align the holes in the base with the well nuts. Install the screws through the base, into the well nuts, and tighten until snug.

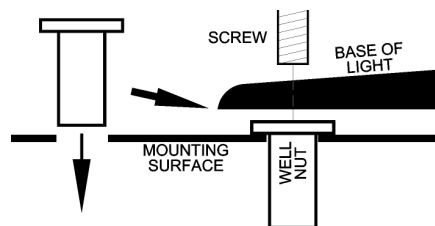

Wiring Instructions

CAUTION: All of our DC powered warning lights are polarity sensitive. These lights are polarity protected *only if the appropriate fuse* is used. All wires connected to the positive terminal of the battery should be fused at the battery for their rated load. **Testing the light before this fuse is properly installed will void the warranty on the light.**

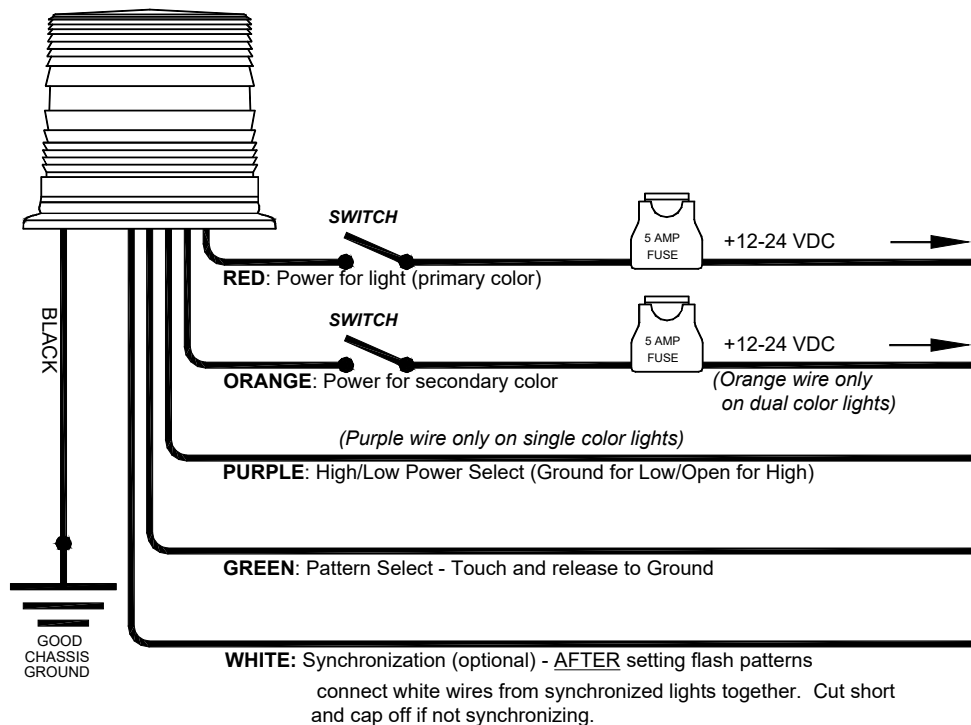

- **Manually Switched High/Low Power:** Connect the Purple wire to Ground

High/Low Power Settings (single color lights only, excluding BK models) There are 3 modes these lights can be set to work in:

through a switch.

By default all single color lights are set up for Manually Switched High/Low power. This means that you can use the Purple wire to control whether the light operates under high power (day mode) or low power (night mode):

Pattern Programming

- Set the flash pattern using any of the following:
 - Green wire (*permanent mount versions only*)
 - Pattern Select switch on the cig plug (single color mag mount versions)
 - Internal jumper (all versions).

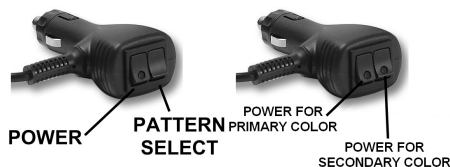

- Power up the light by connecting the Red (and/or Orange, where applicable) and Black wires or by plugging the cig plug into a powered outlet and activating the Power switch(es).
For dual color lights: The cig plug will have two power switches or hard wired versions will have a Red and an Orange wire. Each color can be programmed for its own pattern. Repeat the steps below for each color.

- You can program your light for any of the 12 different patterns in either of two "phases". (Refer to the pattern list below).

- The lights are preset at the factory for Pattern #6/Quadflash. Cycle through the patterns by:
 - Touching and releasing the green wire to ground.
 - Pressing and releasing the Pattern Select button.
 - Removing the jumper from pins 2&3 and touching and releasing it to pins 1&2.

- After the pattern has been set, tape or place a wrenut over the end of the green wire to prevent it from coming into contact with ground again or replace the jumper on pins 2&3.

- SHORTCUTS:** Use the "shortcuts" shown in the chart below to make the programming of your light easier: Hold the green wire to ground (or hold the Pattern Select Button or hold the Jumper to Pins 1 & 2) for the indicated amount of time to go directly to the indicated pattern.

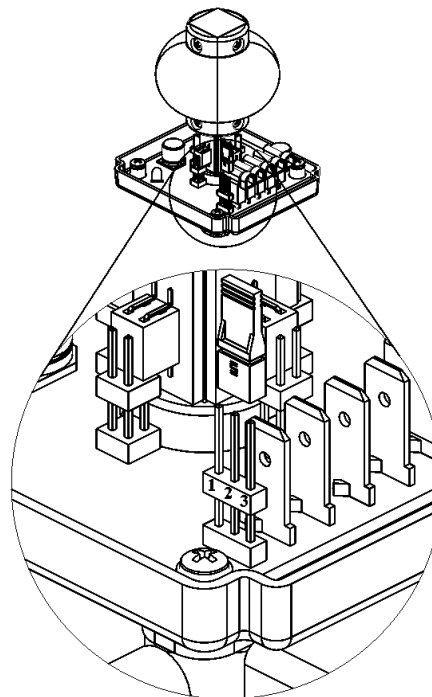

Phase 1 Flash Pattern #	Phase 2 Flash Pattern #	Pattern Type	Pattern Description	CPS	Phase 1 Shortcut	Phase 2 Shortcut
1	13	K	Flicker †	1	3 Sec/1 Blink (Dual Color)	9 Sec/3 Blinks (Dual Color)
2	14	L	Fast Doubleflash	3.3		
3	15	M	Tripleflash †	2.5		
4	16	A5	CCW Rotation 1 †*	1.3	3 Sec/1 Blink (Single Color)	9 Sec/3 Blinks (Single Color)
5	17	A6	CCW Rotation 2	2.7		
6	18	F	Quadflash †‡ (Default Pattern)	1	6 Sec/2 Blinks	12 Sec/4 Blinks
7	19	G	Quadflash w/Post-Pop †‡	1		
8	20	H	Singleflash †‡	1		
9	21	I	Doubleflash †‡	1		
10	22	J	Variable AKA Delta-Omega	0.3		
11	23	C	Post pop 1.4CPS †	1.4		
12	24	E	Random 0.4CPS	0.4		
NA			Steady	NA	18 Sec/5 Blinks	

† - Approved patterns for SAE J845

* - SAE J845 approved pattern only in 8-LED versions † - California Title 13 when properly configured

(Pattern Programming Cont'd)

Steady Burn Mode

To access the Steady Burn pattern, perform any of the following for 18 seconds, until the light blinks 5 times:

- Hold the Pattern Select Button
- Hold Green wire to Ground
- Hold the jumper over pins 1 & 2

Low Voltage Detection

All of these beacons have low input voltage detection. With this feature the beacon senses the input voltage and flashes a fast pattern (approximately 16 cycles per second) to indicate to the user that the battery voltage is low (less than 10V). Once the input voltage returns to normal (greater than 12V) the unit will return to the normal flashing.

Dual Color Operating Modes (Dual Color Lights Only)

Dual-Color Mode

Dual color lights have the ability to activate both colors with one switch/wire. To do this, perform the following:

1. Activate the switch/wire that you want to be dual color.
2. Hold the Pattern Select button/wire/jumper for 21 seconds, until the light blinks 6 times.
3. Deactivate the light.

When you now activate that switch/wire, the selected pattern will cycle back and forth, once in one color, then once in the other color.

Priority Modes

Dual color lights have the ability to allow for different priority options when you activate both colors/functions at the same time. By default, if you activate both functions, they will alternate. Optionally, you can have one mode override the other, or you have an integrated "steady-burn" mode. To change this setting follow these steps:

1. Activate either function/color.
2. Apply **power** to the White wire or to the terminal pictured to the right (the light will stop flashing).
3. Hold the Pattern Select button/jumper (or touch the Green wire to **Ground**) for the corresponding length of time indicated in the chart below.
4. Deactivate the light.

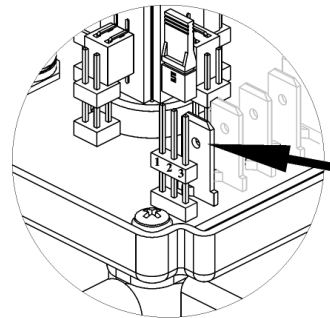

<u>Mode</u>	<u>Description</u>	<u>Shortcut</u>	<u>Flashes</u>
0	No priority, Alternating functions	3 sec.	1
1	Enable 1 overrides Enable 2 when both are active	6 sec	2
2	Enable 2 overrides Enable 1 when both are active	9 sec	3
3	Integrated Steady Burn *	12 sec	4

* *Integrated Steady Burn only works if one function is set to steady burn, otherwise it will act like Mode 1. In this mode, when both functions are activated the light will run the flashing pattern, and in the long off times it will have the steady color dimly lit.*

Synchronization of Multiple Lights

(Permanent Mount Versions Only)

You can synchronize up to six total **S-LINK SYSTEM** approved lights.



If you will be synchronizing two or more units together, leave the white wires disconnected until programming for each has been completed. Connect the white wires from the units together **ONLY AFTER PROGRAMMING** them all for the same **Pattern Type** (Phase MAY differ).

If you will be synchronizing your light with any of our **S-LINK SYSTEM** products, please note the following:

- All units that are to be synchronized MUST have the same **Pattern Type**.
 - To check pattern compatibility with other “S-Link” products, review the **Pattern List** for each product, noting the **Pattern Type**. Certain patterns are compatible with some lights, but not compatible with others.
 - Although the programmable **Flash Patterns** can vary between our different lights, Pattern Types F, G, H, I, & J are fully compatible patterns with ALL of our other “S-Link” products.
1. Determine whether you want the two lights to flash alternately or simultaneously (*Review the diagram below for examples of Alternating and Simultaneous flashing*).

Alternating Mode **Simultaneous Mode**
 2 Complete flash cycles shown 2 Complete flash cycles shown
 Head 1 Head 2 Head 1 Head 2

2. Review the **Pattern List** for each synchronized product, noting the **Pattern Type** for each product.

3. Select a **Pattern Type** that is compatible with all of the lights/flashers you will be synchronizing.

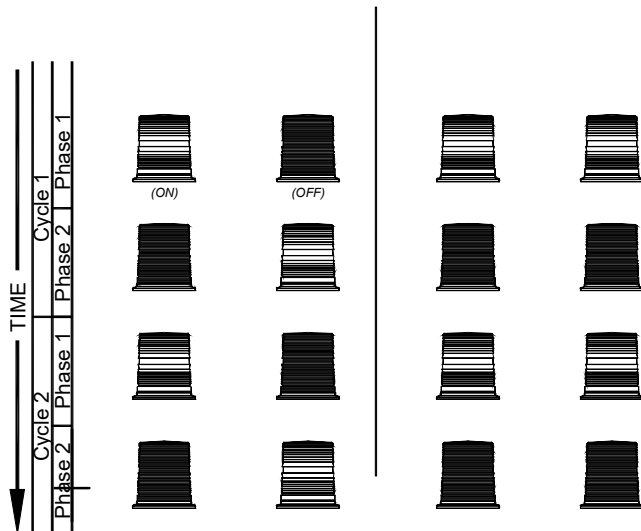

4. Program each light according to the instructions enclosed with each. All lights programmed for the same Phase will flash ON and OFF at the same time (simultaneously). Lights that are programmed for different phases will flash opposite one another (alternate).
5. **After** you have the correct patterns programmed for **ALL** of the lights you wish to synchronize, **turn all of the lights off** and connect the white wires from all units together.
6. Power all of the lights up **at the exact same time** to verify they are flashing in the desired pattern. **Power MUST be applied to all synchronized lights simultaneously. Excessive switch bounce or attempting to power the units up independently will result in erratic operation.**

Photocell

Certain Models Only

These versions have a built in photocell that can detect the ambient light and automatically switch the light between high power (day mode) and low power (night mode).

Please note: By default these models are set to auto-switch between Day and Night mode. To change this, proceed below.

To Deactivate Day/Night Auto-Switching:

1. Activate the light.
2. Apply +12V to the White wire.
3. Hold Green wire to Ground for 3 sec. (Unit will respond by flashing once).
4. Disconnect White wire from +12V.

The light will now be configured with Day/Night auto-switching deactivated and will always run in high power mode.

To Activate Day/Night Auto-Switching:

1. Activate the light.
2. Apply +12V to the White wire.
3. Hold Green wire to Ground for 6 sec. (Unit will respond by flashing two times).
4. Disconnect White wire from +12V.

The light will now be configured with Day/Night auto-switching activated.

Please note: Although the light is set to auto-switch, Grounding the Purple wire will still force the light into night mode (low power)