

INSTRUCTION SHEET

HITACHI S. U. CARBURETOR - MODEL HJG46W

(DUAL CARBURETORS)

GENERAL EXPLODED VIEW

THE GENERAL DESIGN AND PARTS SHOWN WILL VARY TO
INDIVIDUAL UNITS COVERED ON THIS INSTRUCTION SHEET.

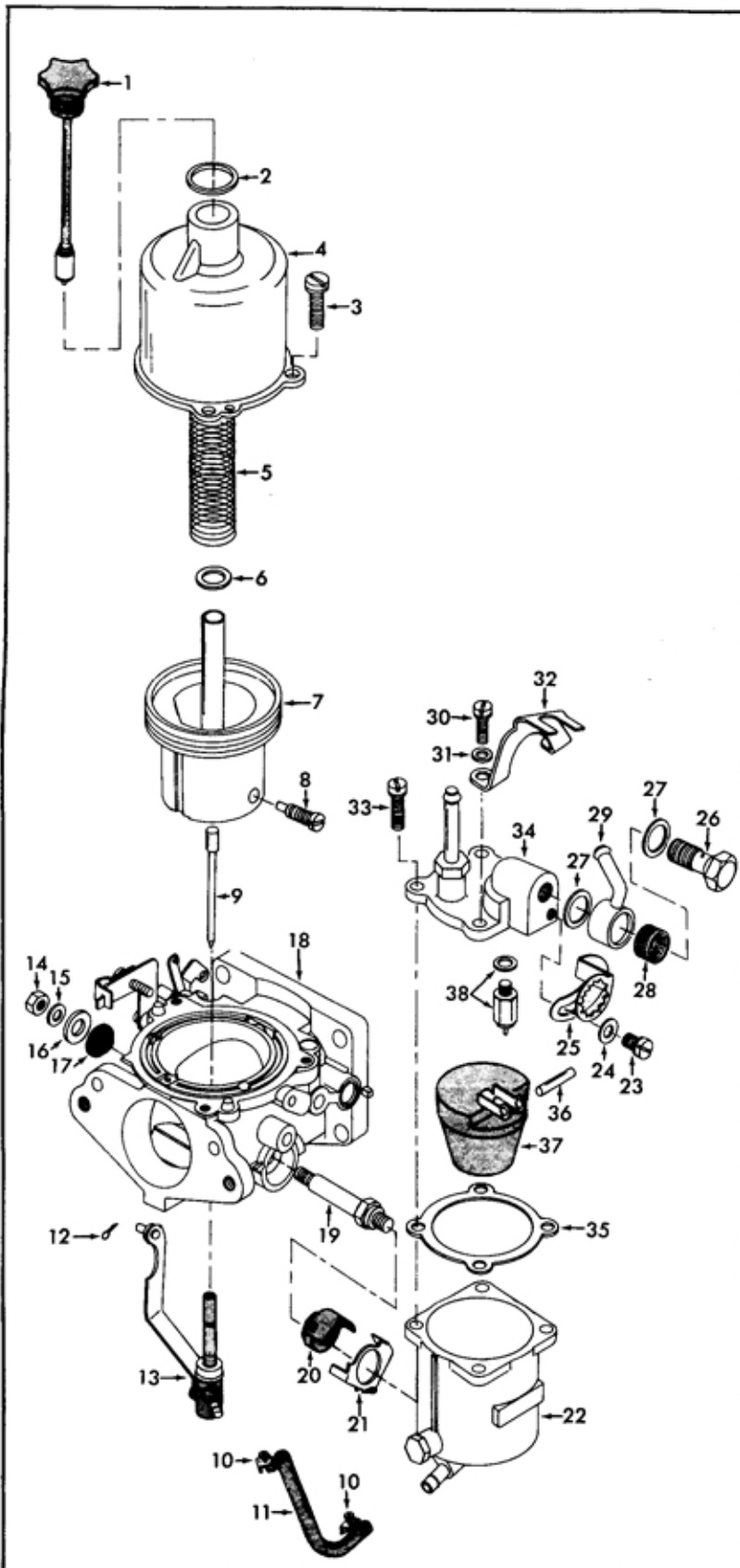

DISASSEMBLY

USE EXPLODED VIEW AS A GUIDE. ALWAYS DISASSEMBLE CARBURETORS INDIVIDUALLY AS PARTS SHOULD NOT BE INTERCHANGED. THE NUMERICAL SEQUENCE MAY GENERALLY BE FOLLOWED TO DISASSEMBLE UNIT FAR ENOUGH TO PERMIT CLEANING AND INSPECTION. CAUTION: SUCTION CHAMBER AND PISTON ASSY. ARE PRECISION MADE AND MUST NOT BE TREATED ROUGHLY. DO NOT DISASSEMBLE NOZZLE (13). RUBBER GROMMETS (17)(20) MUST BE REMOVED BEFORE SOAKING IN CARBURETOR CLEANER.

NOMENCLATURE

REF. NO.	REF. NO.
1. OIL CAP NUT ASSY.	20. ADAPTER (RUBBER) - BOWL STUD
2. GASKET - OIL CAP NUT	21. WASHER - FUEL BOWL SUPPORT
3. SCREW & LOCKWASHER (3) - SUCTION CHAMBER	22. FLOAT BOWL & COVER ASSY.
4. CHAMBER - SUCTION	23. SCREW & LOCKWASHER - BOLT CLAMP
5. SPRING - SUCTION CHAMBER	24. WASHER (FLAT) - BOLT CLAMP SCREW
6. WASHER (PLASTIC) - SUCTION PISTON	25. CLAMP - BOLT
7. PISTON - SUCTION	26. BOLT - FILTER NIPPLE
8. SCREW - NEEDLE JET LOCK	27. GASKET (2) - BOLT
9. NEEDLE - JET	28. SCREEN - FILTER
10. CLAMP (2) - FUEL PIPE	29. NIPPLE - FUEL
11. PIPE - FUEL	30. SCREW & LOCKWASHER (2) - NIPPLE BRACKET
12. COTTER PIN - CONNECTING PLATE	31. WASHER (2) FLAT - BRACKET SCREW
13. NOZZLE & CONNECTING PLATE ASSY.	32. BRACKET - NIPPLE
14. NUT - BOWL STUD	33. SCREW & LOCKWASHER (2) - BOWL COVER
15. LOCKWASHER - BOWL STUD	34. BOWL COVER ASSY.
16. FLAT WASHER - BOWL STUD	35. GASKET - BOWL COVER
17. ADAPTER (RUBBER) - BOWL STUD	36. PIN - FLOAT
18. THROTTLE BODY ASSY.	37. FLOAT & LEVER ASSY.
19. BOLT - FUEL BOWL ATTACHING	38. NEEDLE, SEAT & GASKET ASSY.

CLEANING

CLEANING MUST BE DONE WITH CARBURETOR COMPLETELY DISASSEMBLED. SOAK PARTS LONG ENOUGH TO SOFTEN AND REMOVE ALL FOREIGN MATERIAL. USE A CARBURETOR CLEANING SOLVENT. MAKE CERTAIN THE THROTTLE BORE IS FREE OF ALL CARBON AND VARNISH DEPOSITS. RINSE OFF IN SUITABLE SOLVENT. BLOW OUT ALL PASSAGES IN CASTINGS WITH COMPRESSED AIR AND CHECK CAREFULLY TO INSURE THOROUGH CLEANING OF OBSCURE AREAS. CAUTION: DO NOT SOAK PARTS CONTAINING RUBBER OR PLASTIC MATERIALS.

REASSEMBLY

REASSEMBLE IN REVERSE ORDER OF DISASSEMBLY. NOTE SPECIAL INSTRUCTIONS AND FOLLOW NUMERICAL OUTLINE IN MAKING ADJUSTMENTS.

SPECIAL INSTRUCTIONS

BEFORE INSTALLING NOZZLE (13) - MAKE INITIAL IDLE ADJUSTMENT. TURN IDLE ADJUSTING NUT IN UNTIL IT SEATS, THEN BACK OUT NUMBER OF TURNS ARRIVED FROM CHART. (2 1/2 TURNS GENERAL SETTING)

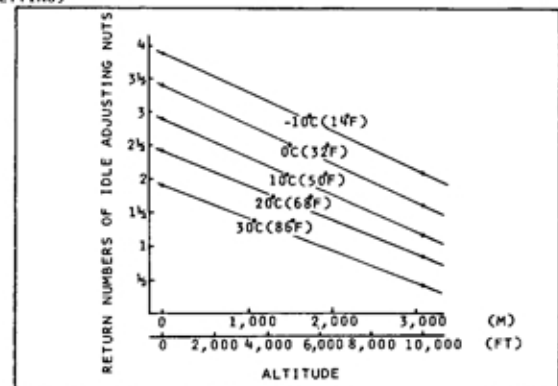

PISTON ASSY. (7) - LUBRICATE PISTON ROD LIGHTLY BEFORE INSTALLING. (LUBRICATE NO OTHER PART OF PISTON.)

ADJUSTMENTS

