

INSTRUCTION SHEET

ROCHESTER CARBURETOR - MODELS 2G-2GC-2GV

08050-359-1

GENERAL EXPLODED VIEW

THE GENERAL DESIGN AND PARTS SHOWN WILL VARY TO INDIVIDUAL UNITS COVERED ON THIS INSTRUCTION SHEET. ON TRIPLE CARBURETOR INSTALLATIONS, THE FRONT AND REAR CARBURETORS DO NOT CONTAIN CHOKE PARTS, IDLE ADJUSTING NEEDLES OR POWER VALVE PARTS.

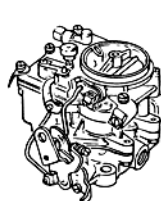
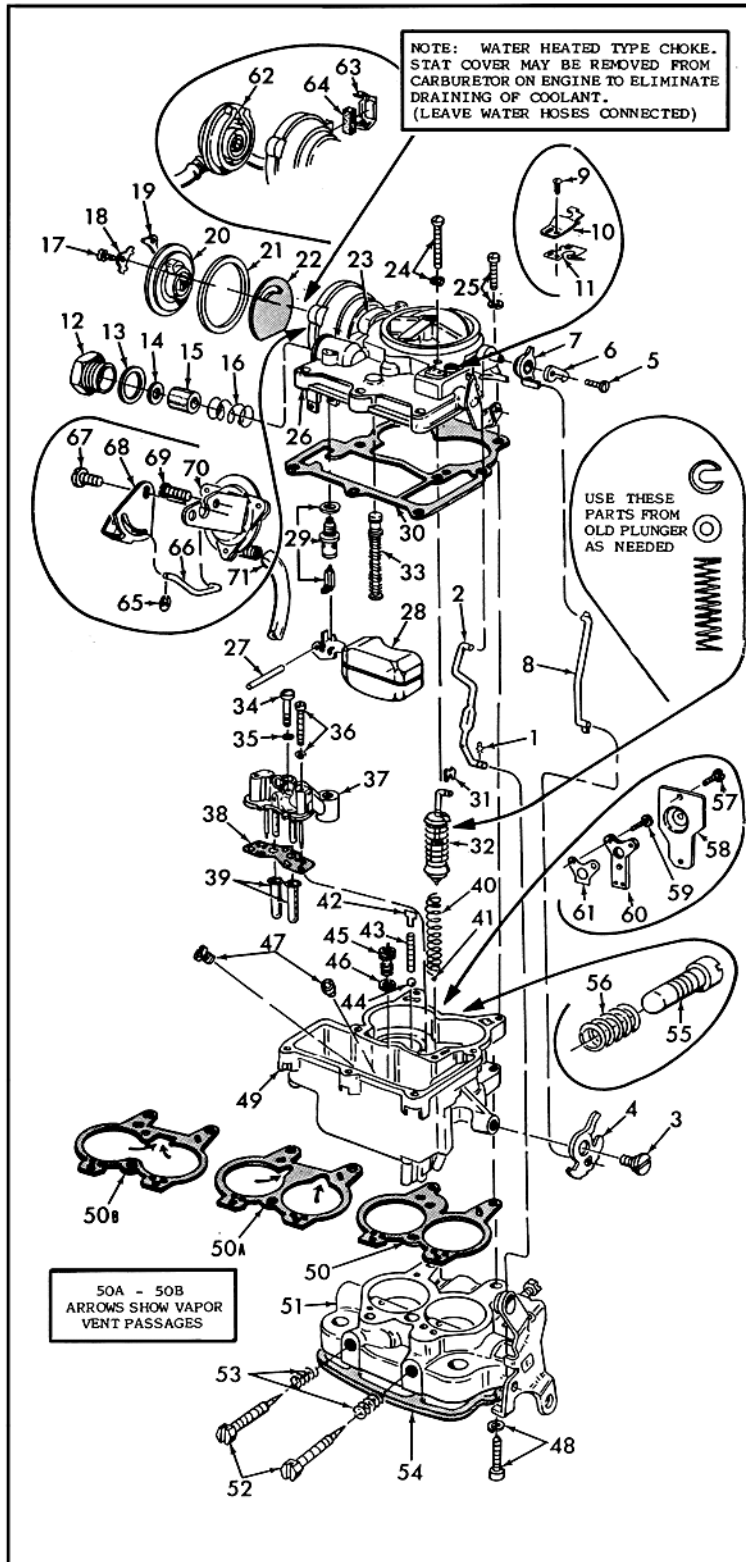

MODEL 2G
HAND CHOKE TYPE

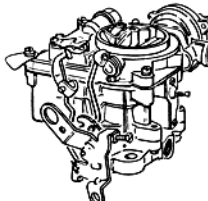

MODEL 2GC
AUTOMATIC CHOKE
VACUUM PISTON AND
STAT COVER TYPE

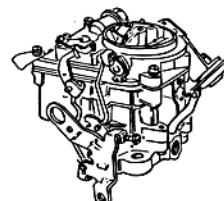

MODEL 2GV
AUTOMATIC CHOKE
VACUUM BREAK TYPE

DISASSEMBLY

USE EXPLODED VIEW AS A GUIDE. THE NUMERICAL SEQUENCE MAY GENERALLY BE FOLLOWED TO DISASSEMBLE UNIT FAR ENOUGH TO PERMIT CLEANING AND INSPECTION. NOTE: BOWL COVER MOUNTED AUTOMATIC CHOKE MODELS USUALLY ONLY REQUIRE REMOVAL OF STAT COVER OR VACUUM UNIT. CAUTION: IF CHOKE SHAFT REQUIRES REMOVAL, CHOKE VALVE SCREWS ARE STAKED OVER, AND STAKING MUST BE FILED OFF BEFORE SCREWS ARE TURNED. HOT WATER TYPE STAT COVERS SHOULD NOT BE DISASSEMBLED UNLESS PARTS ARE BEING REPLACED, AND SHOULD NOT BE IMMERSED IN CLEANER OR SOLVENT. REMOVE STAKING FROM BOWL COVER FOR EASY REMOVAL OF POWER PISTON ASSEMBLY (33). 1968-69 MODELS HAVE SPECIAL ADJUSTMENT SCREWS PLUGGED AND FACTORY SEALED. **DO NOT REMOVE.**

NOMENCLATURE

REF. NO.	NOMENCLATURE	REF. NO.	NOMENCLATURE
1.	RETAINER-PUMP ROD LOWER	41.	BALL-PUMP INTAKE (USED IN TYPES WITH SEAT IN CASTING).
2.	ROD-PUMP	42.	GUIDE-PUMP DISCHARGE BALL
3.	SCREW-FAST IDLE CAM	43.	SPRING-PUMP DISCHARGE BALL
4.	CAM-FAST IDLE	44.	BALL-PUMP DISCHARGE
5.	SCREW-TRIP LEVER	45.	VALVE ASSY.-POWER
6.	LEVER-TRIP	46.	GASKET-POWER VALVE
7.	LEVER AND COLLAR-CHOKE	47.	JETS-MAIN METERING
8.	ROD-CHOKE	48.	SCREW & LOCKWASHER-THROTTLE BODY TO BOWL
9.	SCREW-IDLE VENT VALVE	49.	BOWL ASSY.-FLOAT
10.	SHIELD-IDLE VENT VALVE	50.	GASKET-BODY FLANGE-USED WITH OR WITHOUT IDLE COMPENSATOR (60)
11.	VALVE-IDLE VENT	50A	GASKET-BODY FLANGE-WITH VAPOR VENT SLOTS-FOR TYPES WITHOUT IDLE COMPENSATOR
12.	FITTING-FUEL INLET	50B	GASKET-BODY FLANGE-WITH VAPOR VENT OPENING AND IDLE COMPENSATOR PASSAGE-MAY SUB FOR 50 & 50A
13.	GASKET-FUEL INLET FITTING	51.	THROTTLE BODY ASSY.
14.	GASKET-FUEL FILTER	52.	NEEDLE-IDLE ADJUSTING
15.	FILTER-FUEL INLET	53.	SPRING-IDLE ADJUSTING NEEDLE
16.	SPRING-FUEL FILTER	54.	GASKET-FLANGE
17.	SCREW-STAT COVER RETAINER	55.	NEEDLE-IDLE AIR ADJUSTING (FOR BY-PASS IDLE SYSTEM)
18.	RETAINER-STAT COVER-TOOTHED	56.	SPRING-IDLE AIR ADJUSTING NEEDLE
19.	RETAINER-STAT COVER-PLAIN	57.	SCREW-COVER IDLE COMPENSATOR
20.	STAT COVER & SPRING ASSY.	58.	COVER-IDLE COMPENSATOR
21.	GASKET-STAT COVER	59.	SCREW-IDLE COMPENSATOR VALVE
22.	PLATE-CHOKE BAFFLE	60.	VALVE-IDLE COMPENSATOR
23.	GASKET-CHOKE HOUSING (NOT SHOWN)	61.	GASKET-IDLE COMPENSATOR VALVE
24.	SCREW & LOCKWASHER-BOWL COVER (EXTRA LONG)	62.	STAT COVER & SPRING ASSY. HOT WATER TYPE CHOKE.
25.	SCREW & LOCKWASHER-BOWL COVER	63.	RETAINER-FILTER
26.	BOWL COVER ASSY.	64.	FILTER-AIR INTAKE
27.	PIN-FLOAT HINGE	65.	RETAINER-VACUUM CONTROL ROD (2GV)
28.	FLOAT & LEVER ASSY.	66.	ROD-VACUUM CONTROL (2GV)
29.	NEEDLE, SEAT & GASKET ASSY.	67.	SCREW-STAT ROD LEVER (2GV)
30.	GASKET-BOWL COVER	68.	LEVER-STAT ROD (2GV)
31.	RETAINER-PUMP PLUNGER	69.	SCREW-VACUUM CONTROL ATTACHING
32.	PUMP PLUNGER	70.	VACUUM BREAK CONTROL ASSY. (2GV)
33.	POWER PISTON ASSY.	71.	HOSE-VACUUM BREAK CONTROL (2GV)
34.	SCREW-VENTURI CLUSTER CENTER		
35.	WASHER-FIBER-VENTURI CLUSTER CENTER SCREW.		
36.	SCREW & LOCKWASHER-VENTURI CLUSTER.		
37.	VENTURI CLUSTER ASSY.		
38.	GASKET-VENTURI CLUSTER ASSY.		
39.	INSERT-MAIN WELL		
40.	SPRING-PUMP RETURN		

CLEANING

CLEANING MUST BE DONE WITH CARBURETOR DISASSEMBLED. SOAK PARTS LONG ENOUGH TO SOFTEN AND REMOVE ALL FOREIGN MATERIAL. USE (1) A CARBURETOR CLEANING SOLVENT, (2) LACQUER THINNER OR (3) DENATURATED ALCOHOL. MAKE CERTAIN THE THROTTLE BODY IS FREE OF ALL HARD CARBON DEPOSITS. RINSE OFF IN SUITABLE SOLVENT. BLOW OUT ALL PASSAGES IN CASTINGS WITH COMPRESSED AIR AND CHECK CAREFULLY TO INSURE THOROUGH CLEANING OF OBSCURE AREAS. CAUTION: DO NOT SOAK RUBBER, LEATHER OR PLASTIC PARTS IN SOLVENT.

REASSEMBLY

REASSEMBLE IN REVERSE ORDER OF DISASSEMBLY. NOTE SPECIAL INSTRUCTIONS AND FOLLOW NUMERICAL OUTLINE IN MAKING ADJUSTMENTS. SEE OTHER SIDE.

SPECIAL INSTRUCTIONS

PLUNGER (32) - REMOVE PAPER SLEEVE FROM LEATHER CUP IF USED. FLEX LEATHER CUP OUTWARD SLIGHTLY. SOAK CUP IN GASOLINE, KEROSENE OR OIL FOR A FEW MINUTES PRIOR TO PLACING IN CARBURETOR.

NEEDLE AND SEAT GASKET SELECTION - REFER TO FIGURE 1, PAGE 2.

POWER PISTON INSTALLATION (33) - LIGHTLY STAKE CASTING AROUND WASHER.

IDLE ADJUSTING NEEDLES (52) - TURN EACH NEEDLE IN LIGHTLY UNTIL SEATED, THEN BACK OUT 2-4 TURNS.

IDLE AIR SCREW (55) IF USED - TURN IN TO SEAT AND BACK OUT 2 TURNS.

1967-68 OLDS. PLACE FELT DUST SEAL ON CHOKE PISTON SHAFT BEFORE INSTALLING SHAFT.

ADJUSTMENTS

PROCEDURE NO. 2
WITH GASKET IN PLACE, GAUGE FROM GASKET SURFACE TO SHARP EDGE OF SEAM ON METAL FLOAT OR LIP AT TOE OF PLASTIC FLOAT. (SEE DATA TABLE FOR MEASUREMENT.)

PROCEDURE NO. 1
WITH GASKET IN PLACE, GAUGE FROM GASKET SURFACE TO TOP OF FLOAT. (SEE DATA TABLE FOR MEASUREMENT.)

BEND FLOAT ARM TO ADJ.

CAUTION
DO NOT EXERT PRESSURE ON RESILIENT NEEDLE VALVE

NOTE: WHEN TWO NEEDLE SEAT GASKETS ARE SUPPLIED, USE THIN GASKET FIRST. IF FLOAT MEASUREMENT IS EXTREMELY LOW, THEN REPLACE WITH THICKER GASKET

FLOAT LEVEL ADJUSTMENT Fig. 1

BEND TANG TO ADJUST

WITH FLOAT HANGING FREELY, MEASURE FROM GASKET SURFACE TO BOTTOM OF METAL FLOAT OR LIP OF PLASTIC FLOAT. (SEE DATA TABLE FOR MEASUREMENT.)

FLOAT DROP ADJUSTMENT Fig. 2

MEASURE DISTANCE FROM TOP OF AIR HORN TO TOP OF PUMP ROD. (SEE DATA TABLE FOR MEASUREMENT.)

BACK OUT THROTTLE STOP SCREW. HOLD THROTTLE VALVES TIGHTLY CLOSED

BEND PUMP ROD TO ADJUST

PUMP ROD ADJUSTMENT Fig. 3

(1968-69) ADJUST IDLE VENT VALVE OPENING .020 TO .025 WITH ENGINE AT SPECIFIED IDLE R.P.M. AND IDLE STOP SOLENOID ENERGIZED. (GAUGE AT POINT OF LARGEST VENT VALVE OPENING.)

BEND TANG TO ADJUST

MEASURE DISTANCE BETWEEN VALVE AND VALVE SEAT

THROTTLE VALVE HELD IN CLOSED POSITION

IDLE VENT VALVE ADJUSTMENT Fig. 4

CHOKE VALVE HELD CLOSED

BEND ROD TO ADJUST

PISTON SHOULD BE FLUSH WITH END OF CHOKE PISTON BORE (SEE DATA TABLE)

INTERMEDIATE CHOKE ROD ADJUSTMENT Fig. 5

PISTON LEVER

1959-1960 (EARLY)

CENTER OF GROOVE FLUSH WITH BORE

1960

1st. GROOVE 2nd. GROOVE

1960 (LATE)-1962

FLUSH

OPEN THROTTLE VALVE THEN CLOSE CHOKE VALVE BY PUSHING UPWARD ON INTERMEDIATE CHOKE LEVER AND CHECKING PISTON LOCATION. (SEE DATA TABLE FOR SETTING)

BEND ROD TO ADJUST

INTERMEDIATE CHOKE LEVER

INTERMEDIATE CHOKE ROD ADJUSTMENT SPLIT CHOKE TYPE Fig. 6

ROTATE STAT COVER AGAINST SPRING TENSION. SET MARK ON COVER TO SPECIFIED POINT ON CHOKE HOUSING. (SEE DATA TABLE FOR SETTING)

RICH LEAN

ALLOWABLE VARIATIONS - 2 NOTCHES EITHER WAY FROM INITIAL SETTING

AUTOMATIC CHOKE ADJUSTMENT (2GC) TYPE Fig. 7

MEASURE BETWEEN UPPER EDGE OF CHOKE VALVE AND AIR HORN WALL (SEE DATA TABLE FOR MEASUREMENT)

CHOKE VALVE HELD TOWARD CLOSED POSITION (ROD AGAINST END OF SLOT)

BEND ROD TO ADJUST

PRESS DIAPHRAGM PLUNGER IN UNTIL IT SEATS.

VACUUM BREAK ADJUSTMENT (2GV) TYPE Fig. 8

1968-69 CHEV. MODELS. PRESS DOWNWARD ON ROD TO LIMIT OF TRAVEL. TOP OF ROD END SHOULD BE EVEN WITH BOTTOM OF HOLE IN LEVER.

1968-69 BUICK, PONTIAC, TEMPEST. PULL UPWARD ON CHOKE ROD TO LIMIT OF TRAVEL. ROD END SHOULD FIT IN GAUGE NOTCH OF LEVER.

CHOKE VALVE HELD TIGHTLY CLOSED

1963-67 DISCONNECT ROD. PULL UPWARD CAREFULLY ON ROD TO END OF TRAVEL. 1/2 DIAMETER OF ROD SHOULD BE ABOVE HOLE IN CHOKE LEVER

BEND ROD TO ADJUST

NOTE: ATTEMPT NO ADJUSTMENT ON STAT COIL

AUTOMATIC CHOKE STAT ROD ADJUSTMENT (2GV) TYPE (ON CAR ADJUSTMENT) Fig. 9

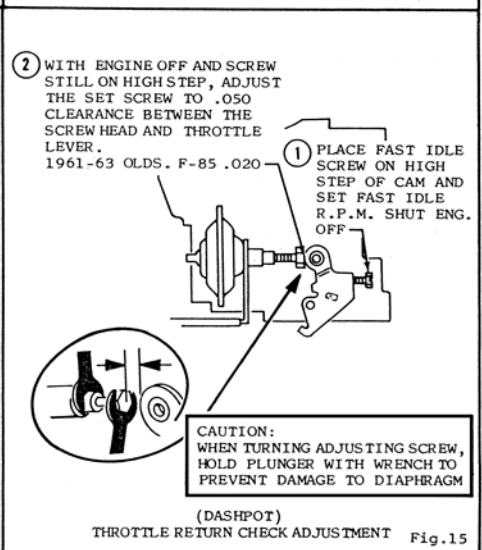
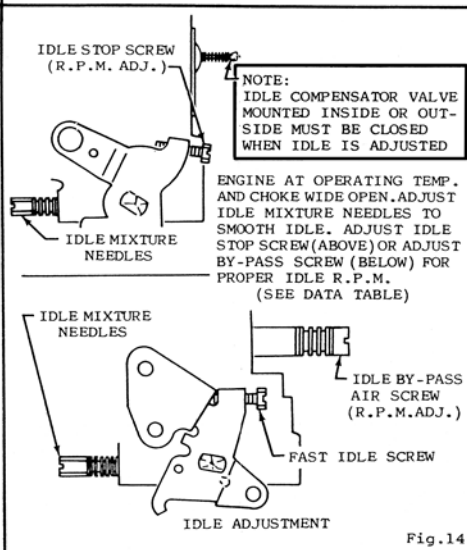
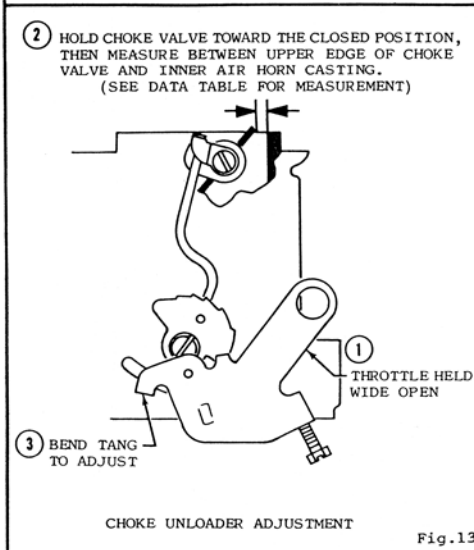
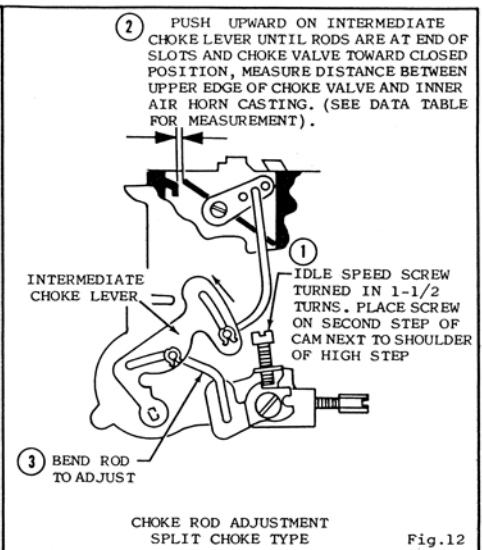
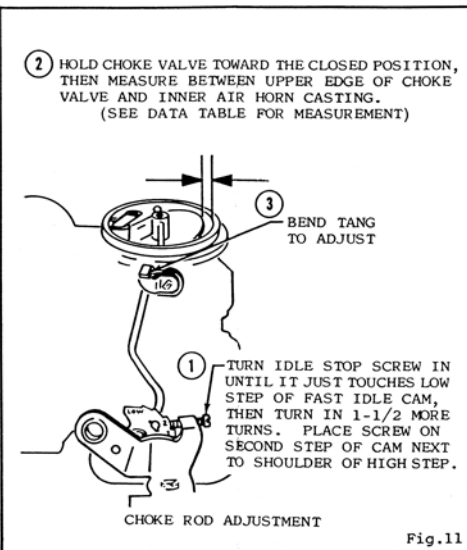
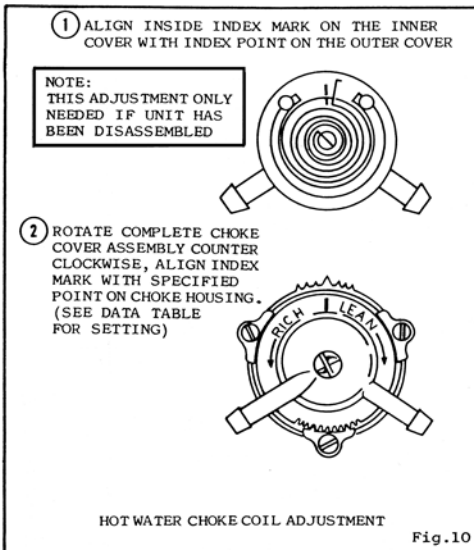

3 X 2 TRI-CARB SET UP - ON CAR ADJUSTMENTS

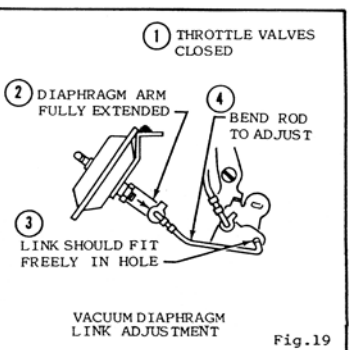
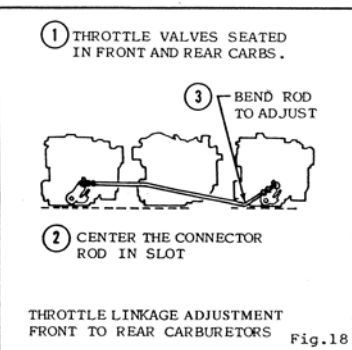
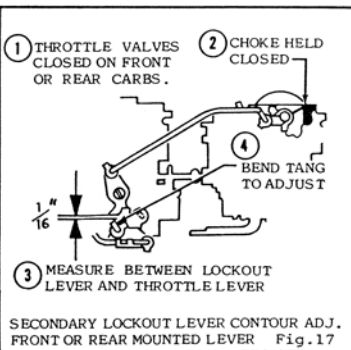
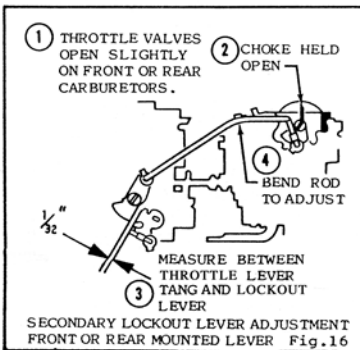

3 X 2 VACUUM SWITCH - ON CAR ADJUSTMENTS

