

FUEL SYSTEM

SERVICE INSTRUCTION WORKSHEET

TO REPAIR

GF3565-15

CARTER CARBURETOR

1 BARREL—MODEL YF

1. Carefully read the text in the following pages to become familiar with the contents of this worksheet before performing carburetor overhaul.
2. The exploded view shown is typical of the model carburetor this kit will service. The view may differ slightly from the actual carburetor being overhauled.

3. Use the exploded view as a guide. The numerical sequence may generally be followed to disassemble the carburetor far enough to permit cleaning and inspection.
4. Parts list shown DOES NOT reflect the contents of this kit.
5. Kit may contain extra parts intended for other carburetors within this group. Substitute identical replacement parts for original worn parts found in carburetor.

CLEANING

Cleaning must be done with carburetor disassembled. Use spray cleaner and a stiff bristle brush to remove dirt and carbon deposits. Do not use abrasives and wires to clean parts and passageways. Wash off in suitable solvent, and clear all passageways with compressed air. **Caution:** When cleaning with solvent do not soak or spray parts containing rubber, leather, plastic and electrical components.

NOTE: Circled parts are included in most kits. Extra parts are included for other kits.

➤ PARTS LIST SHOWN DOES NOT REFLECT THE CONTENTS OF THE KIT.

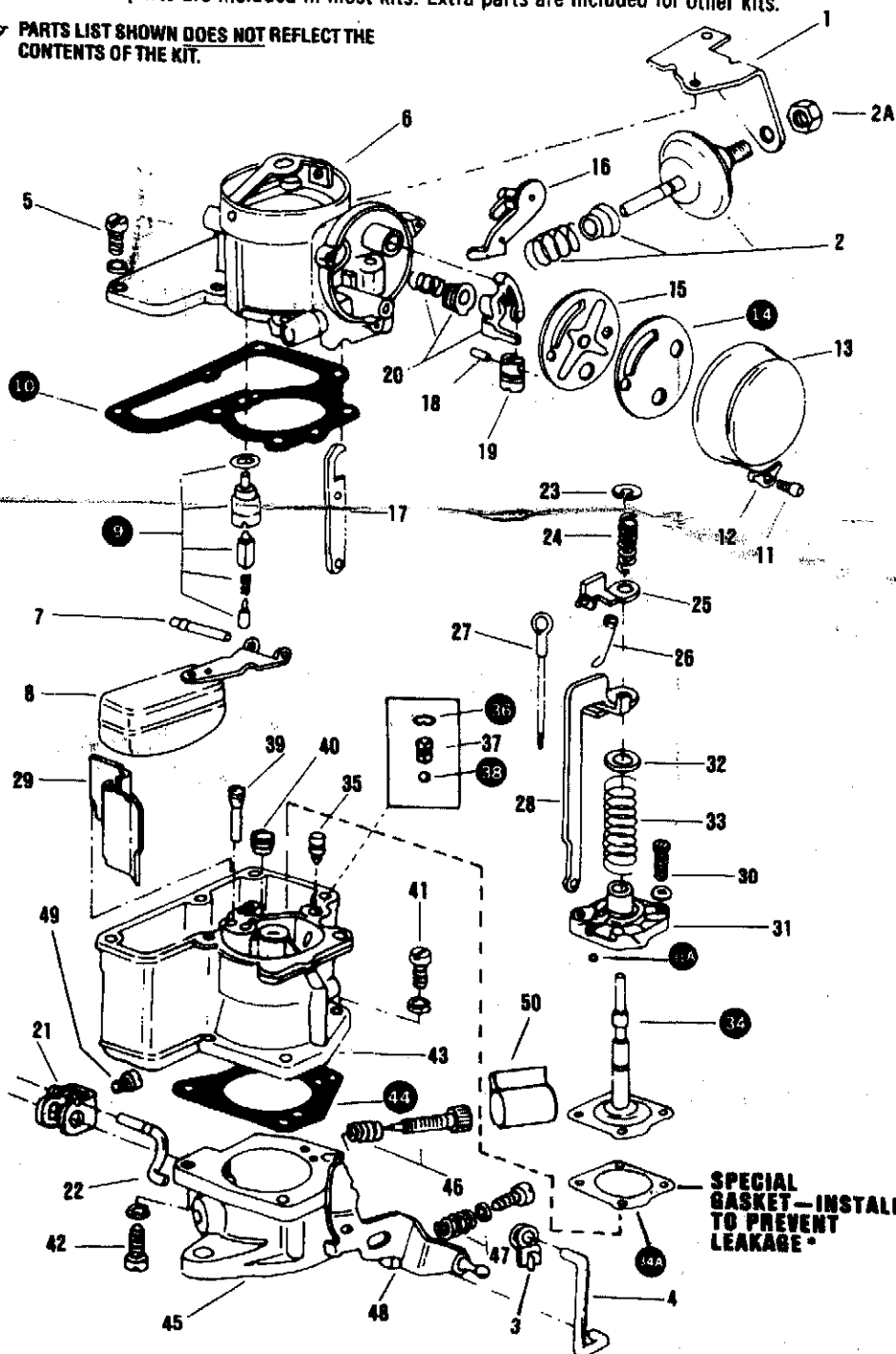

SPECIAL INSTRUCTIONS

1. UPON DISASSEMBLING, BE SURE TO MARK LOCATIONS OF JETS (39, 40) & PUMP PARTS (31A, 35 THRU 38). ALSO THE ANCHORING POINT FOR METERING ROD CLIP (26).
2. INSTALL PUMP DIAPHRAGM ASSEMBLY AS FOLLOWS: PLACE DIAPHRAGM ASSEMBLY UNDERNEATH HOUSING (31), LINE UP HOLES AND INSERT SCREWS. NEXT, SLIDE ON SPRING (33 AND RETAINER 32), PLACE ASSEMBLY IN MAIN BODY (43). START SCREWS, THEN COMPRESS DIAPHRAGM. WHILE IN THIS POSITION, TIGHTEN SCREWS.
3. INSTALL FLOAT PIN (7) WITH SHOULDER ON PIN FURTHEST FROM PUMP DIAPHRAGM.
4. INSTALL MIXTURE SCREW & SPRING UNTIL LIGHTLY SEATED. BACK OUT 2 TURNS.

PARTS LIST

1. Bracket
2. Dashpot Assembly
- 2A. Dashpot Lock Nut
3. Retainer
4. Fast Idle Link
5. Air Horn Screws
6. Air Horn
7. Float Pin
8. Float
9. Needle & Seat Assembly
10. Gasket
11. Choke Coil Cover Screw
12. Retainer
13. Cover
14. Gasket
15. Baffle Plate
16. Trip Lever
17. Fast Idle Link
18. Piston Pin
19. Piston
20. Cam, Sleeve & Spring
21. Throttle Shaft Arm
22. Throttle Shaft Link
23. Pump Shaft Retainer
24. Pump Shaft Spring
25. Metering Rod Arm
26. Metering Rod Clip
27. Metering Rod
28. Pump Lifter Link
29. Fuel Baffle Plate
30. Screws
31. Pump Diaphragm Housing
- 31A. Pump Ball Check, Intake*
32. Diaphragm Stem Retainer
33. Diaphragm Step Spring
34. Pump Diaphragm Assembly
- 34A. Diaphragm Gasket*
35. Pump Check Needle
36. Ball Check Retainer
37. Weight
38. Pump Ball Check, Discharge
39. Low Speed Jet
40. Main Metering Jet
41. Upper Casting Screw & Washer
42. Lower Casting Screw & Washer
43. Main Body
44. Gasket
45. Throttle Body
46. Idle Adjusting Screw & Spring
47. Throttle Adjuster Screw & Spring
48. Throttle Lever
49. Throttle Shaft Arm Screw
50. Limiter Cap*

* Some Models

ADJUSTMENT DATA

SERVICING THE ACCELERATOR PUMP CHECK (EARLY PRODUCTION) WHICH USED DISC CHECK AND WEIGHT IN SPECIFICATION I.D.-F ONLY

Perform modification procedures if applicable as follows:

1. Remove from pump passage: retainer, weight and disc check (See Illustration A).
2. Use 1/8 steel ball, drop it into pump passage, tap it lightly with a 5/32 brass rod and hammer, to form ball seat (DO NOT TAP ALUMINUM BALL). Then remove 1/8 steel ball (See Illustration B).
3. Select 1/8 aluminum ball, drop it into pump passage.
4. Check ball seat by pouring a few drops of gasoline over the ball in pump passage. For a good seat, the gasoline should remain visible for about 60 seconds.
5. Install weight and retainer from kit. (See Illustration C).

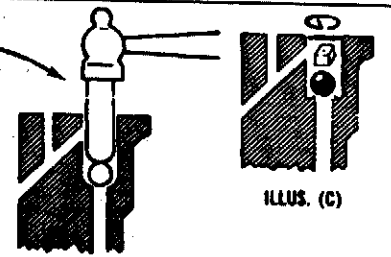
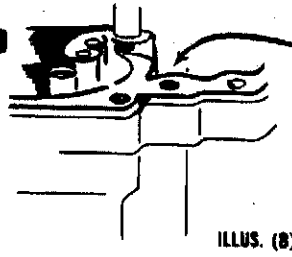

**FIG. A
FLOAT LEVEL ADJUSTMENT**

1. WITH GASKET REMOVED, INVERT BOWL COVER ASSEMBLY SO THAT ONLY WEIGHT OF FLOAT RESTS AGAINST NEEDLE.
2. MEASURE THE DISTANCE ("X" LATE TYPE, "Y" EARLY TYPE FLOAT) FROM THE BOWL COVER TO THE TOP OF THE FLOAT.
3. TO ADJUST, CAREFULLY BEND FLOAT ARM SO IT JUST RESTS AGAINST THE NEEDLE PIN ONLY WITHOUT COMPRESSING SPRING. IF THE RUBBER ON THE NEEDLE DOES BECOME COMPRESSED, ALLOW IT TO SLOWLY RECOVER BACK TO ITS ORIGINAL SHAPE, BEFORE MAKING ADJUSTMENT.

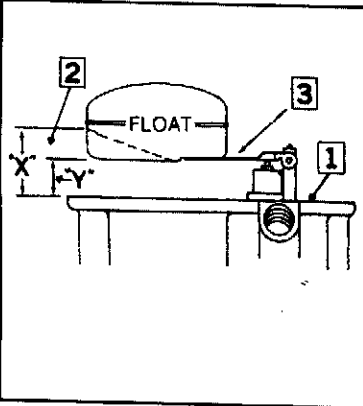

**FIG. D
METERING ROD ADJUSTMENT**

1. WITH THROTTLE VALVES FULLY CLOSED, PRESS DOWN ON UPPER END OF DIAPHRAGM SHAFT UNTIL IT BOTTOMS. METERING ROD SHOULD TOUCH BOTTOM OF METERING ROD WELL.
 2. METERING ROD ARM SHOULD CONTACT LIFTER LINK AT OUTER END NEAREST SPRING AND SUPPORTING LUG.
 3. TO ADJUST, BEND LIP OF METERING ROD.
- NOTE: ON YFA MODELS, REPEAT ABOVE STEPS TO WHERE ROD BOTTOMS IN METERING WELL; THEN TURN ADJUSTING SCREW IN (CLOCKWISE) UNTIL IT CONTACTS LIFTER, THEN ONE ADDITIONAL TURN FOR FINAL ADJUSTMENT.

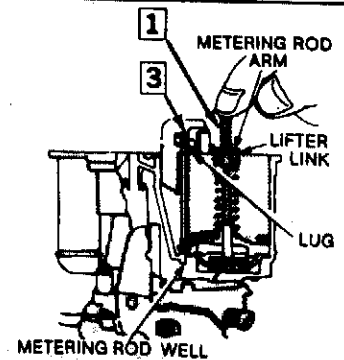

**FIG. B
FLOAT DROP ADJUSTMENT**

1. HOLD AIR HORN ASSEMBLY UPRIGHT.
2. MEASURE DISTANCE ("W" LATE TYPE, "Z" EARLY TYPE FLOAT) BETWEEN PARTING SURFACE OF AIR HORN AND TOP OF FLOAT.
3. TO ADJUST, BEND BOTH STOP TABS AN EQUAL AMOUNT AS SPECIFIED.

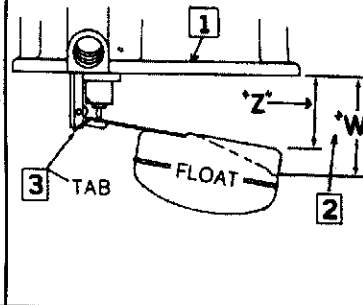

**FIG. E
IDLE VENT ADJUSTMENT**

- NOTE: CLOSE THROTTLE VALVE.
1. MEASURE DISTANCE BETWEEN VENT VALVE AND INSIDE SURFACE OF BOWL COVER. TO ADJUST TURN SCREW IN VENT VALVE.

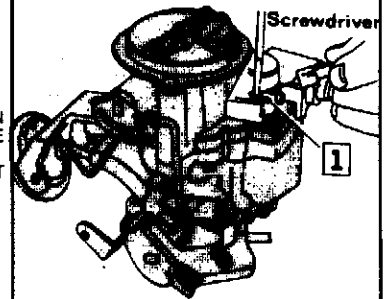

**FIG. C
ACCELERATOR PUMP
ADJUSTMENT**

1. WITH THROTTLE VALVE CLOSED, PUSH DOWN ON THE DIAPHRAGM STEM UNTIL IT BOTTOMS. THE METERING ROD ARM (EXP. VIEW, 25) SHOULD JUST CONTACT PUMP LIFTER LINK (18).
2. TO ADJUST BEND LINK.

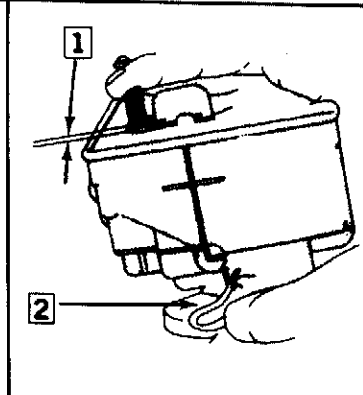

**FIG. F
FAST IDLE ROD ADJUSTMENT**

- NOTE: HOLD CHOKE VALVE WIDE OPEN.
1. THE LIP OF FAST IDLE ARM SHOULD JUST TOUCH BOSS ON CASTING.
 2. BEND LINK TO ADJUST

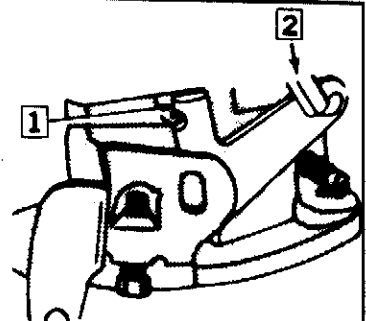

ADJUSTMENT DATA (Cont'd)

**FIG. G
FAST IDLE CLEARANCE**

NOTE: HOLD THROTTLE VALVE AND CHOKE VALVE IN FULLY CLOSED POSITION.

1. INDEX MARK ON FAST IDLE CAM SHOULD LINE UP WITH THE UPPER EDGE OF TANG ON THROTTLE LEVER.
2. BEND ROD TO ADJUST.

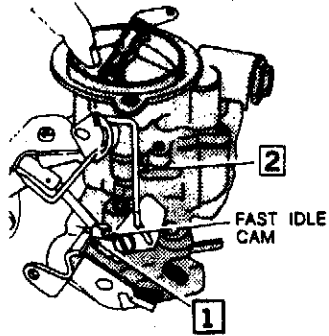

**FIG. K
CHOKE PULLDOWN CLEARANCE**

NOTE: WITH THROTTLE VALVE FULLY OPENED, MOVE CHOKE VALVE TOWARD CLOSED POSITION.

1. MEASURE BETWEEN BOTTOM EDGE OF CHOKE VALVE AND INNER WALL OF AIR HORN.
2. TO ADJUST BEND TRIP LEVER ON CHOKE ARM.

LATE MODELS

NOTE: BEND A .026" DIA. WIRE GAUGE TO AN "L" SHAPE.

- 1A. INSERT GAUGE IN CHOKE PISTON SLOT, TURN LEVER COUNTER CLOCKWISE UNTIL GAUGE IS HELD SNUGLY IN SLOT.
1. MEASURE CLEARANCE BETWEEN BOTTOM EDGE OF CHOKE VALVE AND INNER WALL OF AIR HORN.
2. TO ADJUST, BEND TRIP LEVER ON CHOKE ARM.

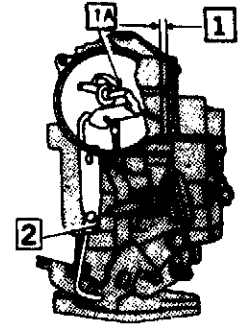

**FIG. H
UNLOADER ADJUSTMENT**

NOTE: HOLD THROTTLE VALVE AND CHOKE VALVE IN FULLY CLOSED POSITION.

1. MEASURE BETWEEN LOWER EDGE OF CHOKE VALVE AND INNER WALL OF AIR HORN.
2. BEND TANG ON THROTTLE LEVER TO ADJUST.

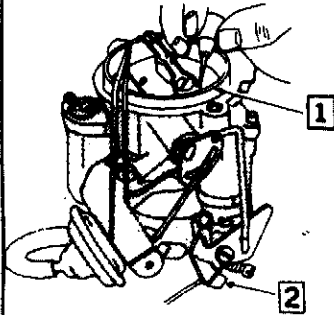

**FIG. L
FAST IDLE SPEED ADJUSTMENT**

NOTE: WITH THROTTLE VALVE WIDE OPEN CLOSE CHOKE VALVE AND ALLOW FAST IDLE CAM TO ROTATE TO HIGH POSITION; CLOSE THROTTLE.

1. MEASURE BETWEEN EDGE OF THROTTLE VALVE AND BORE.
2. TO ADJUST, BEND CONNECTOR ROD.

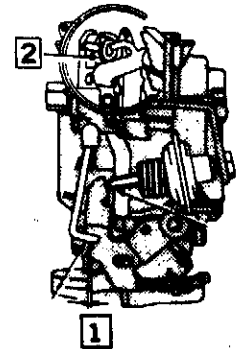

**FIG. I
FAST IDLE CHOKE ROD ADJUSTMENT**

NOTE: MODELS WITH AUTOMATIC CHOKE.

1. MEASURE BETWEEN CASTING BOSS AND TANG ON THROTTLE ARM. CLEARANCE SHOULD BE .015".
2. BEND TANG TO ADJUST.

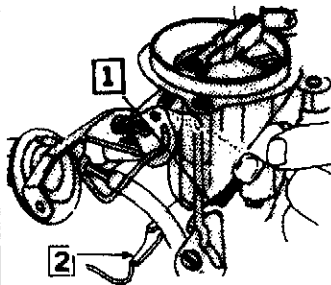

**FIG. M
AUTO CHOKE ADJUSTMENT**

1. ROTATE CHOKE COVER AGAINST SPRING TENSION TO SPECIFIED MARK ON CHOKE HOUSING.

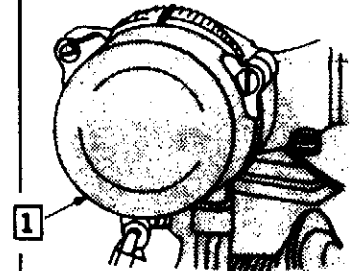

**FIG. J
VACUUM BREAK ADJUSTMENT**

1. FULLY DEPRESS CHOKE PULL OFF PLUNGER. USE A RUBBER BAND TO HOLD CHOKE VALVE TOWARD A CLOSED POSITION.
2. MEASURE BETWEEN LOWER EDGE OF CHOKE VALVE AND INNER WALL OF AIR HORN.
3. BEND LINK TO ADJUST.

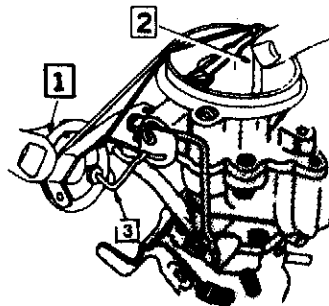

**FIG. N
IDLE SPEED & MIXTURE ADJUSTMENT**

1. SET MIXTURE SCREW 1 1/2 TURNS OPEN FROM LIGHTLY SEATED POSITION. THIS IS ONLY AN INITIAL ADJUSTMENT.
2. SET FAST IDLE SCREW ON PROPER STEP OF CAM AND TURN TO ACHIEVE SPECIFIED R.P.M.

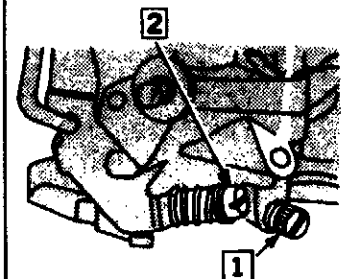

SPECIFICATIONS BY APPLICATION

Year	MODEL	Float Level Fig. A	Float Drop Fig. B	Fast Idle Speed Adj. Fig. L	Unloader Adj. Fig. H	Vacuum Break Fig. J	Choke Pull-down Fig. K	Auto Choke Setting Fig. M	Idle Vent Setting Fig. E	Idle Screw Turns Open Fig. N	Idle Speed		
											Hot ⁵⁴	Fast	
CHEVROLET — SPECIFICATION I.D.-A													
1962-57 1956-53	Service Carb. - 6 Cyl. 235 Eng.	1/2 9/32	1-1/4 1-1/4	3/64 —	7/32 —	— —	— —	1 Rich —	— —	1/2-2 1/2 1/2-1 1/2	425 ⁵⁰ 475	475 M/T	
1952-37 1949-41; 1936-32	6 Cyl. 216 Eng. -Service Carb.	9/32 ⁶ 9/32	1-1/4 1-1/4	3/64 —	1/4 —	— —	— —	1 Rich —	— —	1/2-2 1/2 3/4-1 1/4	— —	—	
GM TRUCKS — SPECIFICATION I.D.-A													
1962-60 1959-50 1953-52	235 Eng. -Roch. Repl. 235 Eng. -Roch. Repl. 216 Eng. -Service Carb.	1/2 9/32 9/32	1-1/4 1-1/4 1-1/4	3/64 — —	1/4 — —	— — —	— — —	1 Rich — —	— — —	1-2 1/2 1/2-1 1/2 1/2-1 1/2	550 475 420	—	
IHC TRUCKS — SPECIFICATION I.D.-A													
1953	R180, 184	3/8	1-3/16	—	—	—	—	—	—	3/4-1 1/4	400	—	
JEEP — SPECIFICATION I.D.-A													
1966-56	226 Eng.	9/32 ⁸	1-1/4	3/64	1/4	—	—	1 Rich	—	1-2 1/2	550	—	
CHECKER — SPECIFICATION I.D.-B													
1965-64	230 Eng.	7/16	1-1/4	3/64	1/4	—	—	Index	1/16	3/4-2 1/4	500 ^{49 50}	—	
CHEVROLET — SPECIFICATION I.D.-B													
1966-62	153 Eng.	7/16 ¹⁶	1-3/16	—	—	—	—	—	1/16	3/4-2 1/2	500 ⁵⁰	—	
GM TRUCKS — SPECIFICATION I.D.-B													
1966-64 1967-62	153 Eng. 194, 230 Eng. -Less Cal.	7/16 ¹⁶ 7/16	1-3/16 1-1/4	— —	— —	— —	— —	— —	1/16 1/16	3/4-2 1/2 1/4-2 1/4	500 ⁵⁰ 500 ⁴⁸	—	
OPEL — SPECIFICATION I.D.-B													
1971-66	130 Eng.	7/16	1-1/4	—	—	—	—	Manual	1/16	3/4-2 1/2	500/600	—	
CHEVROLET — SPECIFICATION I.D.-C													
1967	153 Eng. 194, 230, 250 Eng. -A/T -Cal. 194 Eng. -M/T -Cal. 230, 250 Eng. -M/T -Cal. 250 Eng. -Less Cal. 230, 250 Eng. -Service Carb.	7/32 7/32 7/32 7/32 7/32 7/32	1-3/16 1-3/16 1-1/4 1-3/16 1-1/4 1-1/4	— 12 — — — —	1/4 1/4 1/32 1/4 1/4 1/4	— — — — — —	15/64 — 15/64 15/64 19/64 ²³	— — — — — —	Index Index Index Index Index	1/16 1/16 1/16 1/16 1/16	3/4-2 1/2 1/2-2 1-2 1/2 3/4-1 3/4 1/2-2 1/2 1/2-2 1/2	500 ¹⁵ 600 ¹⁴ 27 700 ⁴⁹ 500 ¹⁶ 500 ^{49 50}	—
1967-62 1966 1966-63	153 Eng. -Service Carb. 194, 230, 250 Eng. -Cal. 250 Eng. -Taxi 194, 230 Eng. -Service Carb.	7/32 1/2 7/32 7/32	1-1/4 1-1/4 1-1/4 1-1/4	— — — —	1/4 1/64 1/4 1/4	— — — —	— — 19/64 ²³ 19/64 ²³	— — — —	1/16 1/16 1/16 1/16	3/4-2 1/2 1/4-1 1/2 1/2-2 1/2 1/2-2 1/2	500 ⁴⁸ 600 ^{11 50} 500 ^{48 50} 500 ^{49 50}	—	
FORD, MERCURY — SPECIFICATION I.D.-C													
1969	170 Eng. -Bronco -Falcon -A/T -M/T -Service Carb.	7/32 7/32 7/32 7/32	1-1/4 1-1/4 1-1/4 —	— — — —	— 3/64 3/64 1/32	— 9/32 9/32 1/32	— — — —	— 9/32 — —	Index 1 Lean 1 Lean	— — — —	55 55 55 600	27 27 700 ⁴⁸	—
1968	170 Eng. -Bronco -Falcon	7/32 7/32	1-1/4 —	— —	— 1/32 ¹⁷	— 1/32	— —	— —	— 1 Lean	— —	55 —	700 700 ^{18 48}	—
1967	170 Eng.	7/32	1-1/4	—	—	—	—	1/4	—	1/2-2	550 ¹⁸	—	
FORD TRUCK — SPECIFICATION I.D.-C													
1969 1968	All 170, 240 Eng. -Early 240 Eng. -Late; All -Service Carb.	7/32 7/32 7/32	1-1/4 1-1/4 1-1/4	— — —	— — —	— — —	— — —	— — —	— — —	— — —	55 55 55	27 25 700 ²⁴ 27 25	—
JEEP — SPECIFICATION I.D.-C													
1972 1971 1970 1970-68 1967-65	134 Eng. 134 Eng. 134 Eng. -Late 134 Eng. -Early '70 C.J. DJ Series -4 Cyl.	1/4 1/4 1/4 1/4 1/2	1-1/4 1-1/4 1-1/4 1-1/4 1-1/4	— — — — —	— — — — —	— — — — —	— — — — —	— — — — —	Manual — — — —	— — — — —	— 55 55 55 600N	— — — — —	—
GM TRUCKS — SPECIFICATION I.D.-C													
1967	153 Eng. 194 Eng. 230, 250 Eng. -G10 -Less Cal. 230, 250, 292 Eng. -w/Cal. -A/T -M/T	7/32 7/32 7/32 7/32 7/32	1-3/16 1-1/4 1-1/4 1-1/4 1-1/4	— — — — —	1/4 1/4 1/32 1/4 1/4	— — — — —	— — — — —	15/64 — — — —	— — — — —	1/16 1/16 1/16 1/16 1/16	3/4-2 1/2 1-2 1/2 1/2-2 1/4 1/2-2 1/4-1 3/4	500 ¹⁵ 27 500 ⁴⁸ 500 ⁴⁸ 700 ⁴⁸	—
1967-64 1967-63 1966	153 Eng. -Service Carb. 292 Eng. -1/2 Ton Roch. Repl. 230, 250 Eng. -Roch. Repl. 194, 230, 250 Eng. -Cal. 194, 230 Eng. -G10 -A/T -Cal. -Service Carb.	7/32 7/32 7/32 1/2 7/32	1-1/4 1-1/4 1-1/4 1-1/4 1-1/4	— — — — —	— — — 1/64 1/4	— — — 17/64 —	— — — — —	— — — 7/32 —	— — — — —	1/16 1/16 1/16 1/16 1/16	1/4-2 1/4 1/4-1 3/4 1/4-2 1/4 1/4-2 1/2 1/2-2	500 ⁴⁸ 500 ^{11 48} 500 ⁴⁸ 600 ⁵⁰ 500 ⁴⁸	—
1966-64	194, 230 Eng. -Service Carb.	7/32 7/32	1-1/4 1-1/4	— —	— —	— —	— —	— —	— 1/16	1/4-1 3/4 1/4-2 1/4	500 ^{11 48} 500 ⁴⁸	—	

SPECIFICATIONS BY APPLICATION (Cont'd)

Year	MODEL	Float Level Fig. A	Float Drop Fig. B	Fast Idle Speed Adj. Fig. L	Unloader Adj. Fig. H	Vacuum Break Fig. J	Choke Pulldown Fig. K	Auto Choke Setting Fig. M	Idle Vent Setting Fig. E	Idle Screw Turns Open Fig. N	Idle Speed		
											Hot ⁵⁴	Fast	
OLDSMOBILE — SPECIFICATION I.D.-C													
1967-66	250 Eng. -Roch. Carb.	7/32 ⁶ 7/32	1-3/16 1-1/4	12 7	1/4 1/4	15/64 19/64 ²³	—	Index Index	1/16 1/16	1/2-2 1/2-2 1/2	500 500	—	
OPEL — SPECIFICATION I.D.-C													
1971-66	130, 153 Eng.	7/32 ¹	1-1/14	—	—	—	—	Manual	1/16	1/2-2 1/2	500/600	—	
PONTIAC — SPECIFICATION I.D.-C													
1965-64	215 Eng. -Roch. Repl.	7/32	1-1/4	7	1/4	19/64 ⁴³	—	Index	1/16	1/2-2 1/2	500 ^{49 50}	—	
STUDEBAKER — SPECIFICATION I.D.-C													
1966-65	194, 230 Eng. -Roch. Repl.	7/32	1-1/4	7	1/4	19/64 ²³	—	Index	1/16	1/2-2 1/2	500 ^{49 50}	—	
AMC — SPECIFICATION I.D.-D													
1978	232 Eng. -A/T -M/T 258 Eng. -A/T -Cal. -M/T	15/32 15/32 15/32 15/32 15/32	1-3/8 1-3/8 1-3/8 1-3/8 1-3/8	3/16 3/16 3/16 3/16 3/16	9/32 9/32 9/32 9/32 9/32	— — — — —	7/32 7/32 7/32 7/32 7/32	Index 1 Rich 1 Rich Index Index	— — — — —	55 55 55 55 55	550 600 550 700 600	1800 1600 1600 1600 1500	
1977	232 Eng. -A/T -Cal. -M/T 258 Eng. -A/T -Cal. -M/T -Cal.	15/32 15/32 15/32 15/32 15/32 15/32 15/32	1-3/8 1-3/8 1-3/8 1-3/8 1-3/8 1-3/8 1-3/8	3/16 3/16 3/16 3/16 3/16 3/16 3/16	9/32 9/32 9/32 9/32 9/32 9/32 9/32	— — — — — — —	7/32 7/32 7/32 7/32 7/32 7/32 7/32	1 Rich Index 1 Rich Index 1 Rich Index Index	— — — — — — —	55 55 55 55 55 55 55	550 700 600 850 550 700 600 850	1600 1600 1500 1500 1600 1600 1500 1500	
1976	232, 258 Eng. -Exc. Gremlin Fed. -Gremlin Fed. ⁴⁶	31/64 31/64	1-3/8 1-3/8	13/64 13/64	5/16 5/16	— —	— —	1 Rich 2 Rich	— —	— —	500 500	1650 ⁵² 1650 ⁵²	
1975	232, 258 Eng. -Exc. Matador Fed. ⁴⁶ -Matador Fed.	31/64 31/64	1-3/8 1-3/8	13/64 13/64	5/16 5/16	— —	— —	1 Rich 1 Rich	— —	— —	500/700 —	1800 1600	
1974	232, 258 Eng. -Less Cal. -A/T -M/T -Exc. Matador -Matador -Cal. -w/o Valve Rotators -Valve Rotators	31/64 31/64 31/64 31/64 —	1-3/8 1-3/8 1-3/8 1-3/8 1-3/8	13/64 13/64 13/64 13/64 13/64	5/16 5/16 5/16 5/16 5/16	— — — — —	— 7/32 7/32 — —	1 Rich 1 Rich 1 Rich 1 Rich 1 Rich	— — — — —	55 55 55 55 55	27 700 600 57 27	— — — 27 27	
1973 1/2	232, 258 Eng. -A/T -Exc. Matador -Matador -M/T -A/T -Less Cal. -Service Carb.	31/64 31/64 31/64 31/64	1-3/8 1-3/8 1-3/8 1-3/8	13/64 13/64 13/64 13/64	5/16 5/16 5/16 5/16	— — — —	7/32 7/32 7/32 7/32	1 Rich 1 Rich 1 Rich 1 Rich	— — — 55	55 55 55 55	600 500 700 27	— — — 27	
1973	232, 258 Eng. -Service Carb. -A/T -M/T	31/64 31/64	1-1/4 1-3/8	13/64 13/64	5/16 5/16	— —	7/32 7/32	1 Rich 1 Rich	— 55	55 55	500/700 700	— 27	
1972	232, 258 Eng. ⁴⁵ -Service Carb. -A/T -Less Cal. -M/T	7/16 31/64 31/64	1-1/4 1-3/8 1-3/8	7/32 13/64 13/64	5/16 5/16 5/16	— — —	7/32 7/32 —	Index 1 Rich 1 Rich	— 55 55	55 55 55	600 ^{44 51 52} 700 27	— — 27	
1971	232 Eng. -A/T -Hornet, Gremlin -Less Cal. -Cal. -Rebel, Javelin; 258 Eng. -M/T -Hornet, Gremlin -Rebel, Javelin; 258 Eng. -Service Carb. -All ⁴⁵	7/16 7/16 7/16 7/16 7/16	1-1/4 1-1/4 1-1/4 1-1/4 1-1/4	1/32 1/32 1/32 1/64 1/64	5/16 5/16 5/16 5/16 5/16	— — — — —	— — — — —	— — — — —	1 Rich 1 Rich Index 1 Rich 1 Rich Index	— — — — — —	55 55 55 55 55 55	600 800 800 700 650 —	— — — — — 1600 ⁵²
1970	199, 232 Eng. -Service Carb. ⁴⁶	7/16 7/16	1-1/4 1-1/4	7/32	9/32 ¹⁸ 5/16	— —	1/32 —	Index Index	— 55	55 55	550 ⁴⁴ —	— 1600 ⁵²	
FORD, MERCURY — SPECIFICATION I.D.-D													
1974	200 Eng. -Bronco ⁴⁶ -A.T. -Less Cal. -w/o A.C. -Early ⁴⁶ -Late ⁴⁶ -Cal. -w/o A.C. ⁴⁶ -A.C. -M.T. -w/o A.C. -Early ⁴⁶ -A.C. -Early -M.T. -Late	3/8 3/8 3/8 3/8 3/8 3/8 3/8	1-1/4 1-1/4 1-1/4 1-1/4 1-1/4 1-1/4 1-1/4	1/8 9/64 9/64 9/64 9/64 11/64 11/64	5/16 5/16 5/16 5/16 5/16 5/16 5/16	— — — — — — —	— — — — — — —	— — — — — — —	Index 1 Rich Index Index Index Index Index	— — — — — — —	55 55 55 55 55 55 55	750N 550D 550D 550D 550N 750N 500N 500/800N	— — 2000 ⁵² — — — — 1750
1973	200 Eng. -Bronco ⁴⁶ -A.T. -w/o A.C. -Early ⁴⁶ -Late ⁴⁶ -A.C. -M.T. -w/o A.C. ⁴⁶ -A.C.	3/8 3/8 3/8 3/8 3/8 3/8	1-1/4 1-1/4 1-1/4 1-1/4 1-1/4 1-1/4	1/8 9/64 9/64 9/64 9/64 11/64 11/64	5/16 5/16 5/16 5/16 5/16 5/16 5/16	— — — — — — —	— — — — — — —	— — — — — — —	Index 1 Lean 1 Rich 1 Rich Index Index	— — — — — — —	55 55 55 55 55 55 55	750 550 550 500 750 500	— — — — — —
1972	170 Eng. -M.T. -Bronco 200 Eng. -A.T. -w/o A.C. -A.C. Carb. No. D2PF-EA -M.T.	7/32 3/8 3/8 3/8 3/8	1-1/4 1-1/4 1-1/4 — 1-1/4	7/64 7/64 9/64 9/64 1/4	5/16 5/16 5/16 5/16 5/16	— — — — —	13/64 11/64 13/64 13/64 7/32	Index Index 1 Rich 1 Rich Index	— — — — —	55 — — — —	See Text See Text See Text See Text See Text	750 750 2000 600/500 750 800/750	— 2000 2000 ⁵³ 1600 1750
1971	170 Eng. -Bronco 200 Eng. -A.T. -w/o A.C. -A.C. -M.T. -w/o A.C. -A.C. 170, 200 Eng. -Service Carb. 240 Eng. -A.T. -M.T.	7/32 3/8 3/8 3/8 3/8 3/8 3/8 3/8	1-1/4 1-1/4 1-1/4 1-1/4 1-1/4 1-1/4 1-1/4 1-1/4	7/64 7/64 — — — 11/64 7/64 7/32 3/16	19/64 19/64 5/16 5/16 1/4 1/4 19/64 1/4	— — — — — — — — —	— — — — — — 15/64 ⁴⁵ 15/64 13/64	Index Index 1 Rich 1 Rich Index Index Index Index	— — — — — — — — —	— — — — — — — — —	55 55 55 55 55 55 55 55	550 750 750 600/500 ^{44 51} 750 750/800/500 ^{44 51} 500/550 800/500 ^{44 48} 500 ⁵²	— — — — — — — — —

continued on next page

SPECIFICATIONS BY APPLICATION (Cont'd)

Year	MODEL	Float Level Fig. A	Float Drop Fig. B	Fast Idle Speed Adj. Fig. I	Unloader Adj. Fig. H	Vacuum Break Fig. J	Choke Pull-down Fig. K	Auto Choke Setting Fig. M	Idle Vent Setting Fig. E	Idle Screw Turns Open Fig. N	Idle Speed	
											Hot ⁵⁴	Fast
JEEP — SPECIFICATION I.D.-D												
1978-77	258 Eng. -Cal. M/T	31/64	1-3/8	13/64	9/32	—	7/32	2 Rich	—	—	500	—
1976	232, 258 Eng. -CJ17 -A/T: Cherokee, Wagoneer, J10, 20 -CJ15, 7 -M/T -Less Cal. ⁴⁶ -Cal. ⁴⁶	31/64	1-3/8	13/64	5/16	—	—	1 Rich	—	—	500	1650 ⁵²
		31/64	1-3/8	13/64	5/16	—	—	2 Rich	—	—	500	1650 ⁵²
		31/64	1-3/8	13/64	5/16	—	—	2 Rich	—	—	500	1650 ⁵²
1975	232, 258 Eng. -Exc. Mail Truck ⁴⁶ -Mail Truck	31/64	1-3/8	13/64	5/16	—	—	1 Rich	—	—	500	1650 ⁵²
		31/64	1-3/8	13/64	5/16	—	—	1 Rich	—	—	500	1650 ⁵²
1974	232, 258 Eng. -A/T: M/T -Cal. -w/o Valve Rotators -M/T -Less Cal. -Cal. -w/Valve Rotators	31/64	1-3/8	13/64	5/16	—	—	1 Rich	—	55	500/700	1600
		31/64	1-3/8	13/64	5/16	—	7/32	1 Rich	—	55	600	27
		—	1-3/8	13/64	5/16	—	—	1 Rich	—	55	600	27
1973	232, 258 Eng. -A/T -Early -Late -M/T -Exc. CJ, DJ -Early -Late -CJ, DJ -Early -Late -Mail Truck Van -¾, ½ Ton	7/16	1-1/4	13/64	5/16	—	7/32	1 Rich	—	55	500	—
		31/64	1-3/8	13/64	5/16	—	7/32	1 Rich	—	55	500	—
		7/16	1-1/4	13/64	5/16	—	7/32	1 Rich	—	55	600	—
		31/64	1-3/8	5/16	5/16	—	7/32	1 Rich	—	55	600	—
		7/16	1-1/4	13/64	5/16	—	7/32	1 Rich	—	55	700	—
		31/64	1-3/8	13/64	5/16	—	7/32	1 Rich	—	55	700	—
		7/16	1-1/4	7/32	5/16	—	—	Index	—	55	—	—
1972	232, 258 Eng. ⁴⁶ -Service Carb. ⁴⁶	7/16	1-1/4	7/32	5/16	—	7/32	Index	—	55	600 ⁴⁴ 51 ⁵²	—
		7/16	1-1/4	7/32	5/16	—	—	Index	—	55	—	1600 ⁵²
1971	258 Eng. -A/T -Service Carb. ⁴⁶ -M/T -Service Carb.	7/16	1-1/4	1/32	5/16	—	—	Index	—	55	700	—
		7/16	1-1/4	7/32	5/16	—	—	Index	—	55	—	1600 ⁵²
		7/16	1-1/4	1/32	5/16	—	—	1 Rich	—	55	600	—
		7/16	1-1/4	7/32	5/16	—	7/32	Index	—	55	600 ⁴⁴ 51 ⁵²	—
1971-70	153 Eng.	1/4	1-1/4	—	—	—	—	Manual	—	55	—	—

AMC — SPECIFICATION I.D.-E

1979	232 Eng. -Fed. -A.T., M.T. 258 Eng. -Cal. -A.T.	31/64	1-3/8	13/64	9/32	—	7/32	1 Rich	—	—	—	—
		31/64	1-3/8	13/64	9/32	—	7/32	1 Rich	—	—	—	—
1978	232 Eng. -Fed. -A.T. -M.T. -Can. -All 258 Eng. -Alt. -A.T. -M.T. -Cal. -A.T. -M.T.	15/32	1-3/8	13/64	9/32	—	7/32	1 Rich	—	—	550	1600
		15/32	1-3/8	13/64	9/32	—	7/32	1 Rich	—	—	600	1500
		15/32	1-3/8	13/64	9/32	—	7/32	1 Rich	—	—	600/500	1500
		15/32	1-3/8	13/64	9/32	—	7/32	2 Rich	—	—	550	1600
		15/32	1-3/8	13/64	9/32	—	7/32	1 Rich	—	—	600	1500
		15/32	1-3/8	7/32	5/16	—	—	1 Rich	—	—	700	1600
		15/32	1-3/8	13/64	9/32	—	7/32	Index	—	—	850	1500
1977	232 & 258 Eng. -All -A.T. -M.T. -Alt. -A.T. -M.T. -Cal. -A.T. -M.T. -Can. -All	15/32	1-3/8	13/64	5/16	—	—	1 Rich	—	—	550	1650
		15/32	1-3/8	13/64	5/16	—	—	1 Rich	—	—	—	1500
		15/32	1-3/8	13/64	5/16	—	—	2 Rich	—	—	550	1650
		15/32	1-3/8	13/64	5/16	—	—	1 Rich	—	—	600	1500
		15/32	1-3/8	13/64	5/16	—	—	Index	—	—	500/700	1600
		15/32	1-3/8	13/64	5/16	—	—	Index	—	—	550/850	1500
		15/32	1-3/8	13/64	5/16	—	—	Index	—	—	550/600	1500

JEEP — SPECIFICATION I.D.-E

1979	232, 258 Eng. -Cal. Fed. -M/T	31/64	1-3/8	13/64	9/32	—	7/32	1 Rich	—	—	—	—
1978	232 & 258 Eng. -Fed. -A.T. -Alt. -M.T. 258 Eng. -Cal. -A.T. -All -M.T.	15/32	1-3/8	13/64	9/32	—	7/32	1 Rich	—	—	550	1600
		15/32	1-3/8	13/64	5/16	—	7/32	2 Rich	—	—	600	1500
		15/32	1-3/8	13/64	9/32	—	7/32	Index	—	—	700	1600
		15/32	1-3/8	13/64	5/16	—	7/32	1 Rich	—	—	600/850	1500
1977	232 & 258 Eng. -Fed. -All -Alt. -A.T. -M.T. -All -M.T. 258 Eng. -Cal. -A.T.	15/32	1-3/8	13/64	5/16	—	—	1 Rich	—	—	550	1650
		15/32	1-3/8	13/64	5/16	—	—	2 Rich	—	—	550	1650
		15/32	1-3/8	13/64	5/16	—	—	2 Rich	—	—	600	1650
		15/32	1-3/8	13/64	5/16	—	—	1 Rich	—	—	550/600	1650
		15/32	1-3/8	13/64	5/16	—	—	Index	—	—	550/700	1600

AMC — SPECIFICATION I.D.-F

1962-51	American Rambler	1/2	—	—	—	—	—	—	—	—	½ - 1½	450 - 500 ⁴⁸	—
---------	------------------	-----	---	---	---	---	---	---	---	---	--------	-------------------------	---

IHC TRUCK — SPECIFICATION I.D.-F

1953-50	5D220 Eng. 5D240 Eng.	25/64	—	7	—	—	—	—	—	—	¾ - 1¾	400	—
		5/16	—	7	—	—	—	—	—	—	¾ - 1¾	400	—

JEEP — SPECIFICATION I.D.-F

1967-61	FJ Series—4 Cylinder	9/32 ^a	13/16 ¹⁰	7	—	—	—	—	—	—	½ - 2½	600	—
1965-56	DJ Dispatch—4 Cylinder	9/32 ^a	13/16 ¹⁰	7	—	—	—	—	—	—	½ - 2½	600N	—
1965-52	134 Eng.—Universal, Wagon & FWD/C	1/2	—	7	—	—	—	—	—	—	¾ - 1¾	600N	—
1955-52	6 Cylinder	9/32	—	7	—	—	—	—	—	—	½ - 2	600N	—
1951-50	4 Cylinder—4-73 Eng.	5/16	—	7	—	—	—	—	—	—	½	600N	—
1950	4 Cylinder—4-63 Eng.	9/32	—	7	—	—	—	—	—	—	¾ - 1¾	600N	—