

FUEL SYSTEM SERVICE INSTRUCTION WORKSHEET

TO REPAIR

GF3797-21

ROCHESTER CARBURETOR

2 BARREL --- Model 2SE, E2SE

1. Carefully read the text in the following pages to become familiar with the contents of this worksheet before performing carburetor overhaul.
2. The exploded view shown is typical of the model carburetor this kit will service. The view may differ slightly from the actual carburetor being overhauled.

3. Use the exploded view as a guide. The numerical sequence may generally be followed to disassemble the carburetor far enough to permit cleaning and inspection.
4. Parts list shown **DOES NOT** reflect the contents of the kit.
5. Kit may contain extra parts intended for other carburetors within this group. Substitute identical replacement parts for original worn parts found in carburetor.

TYPICAL ILLUSTRATION

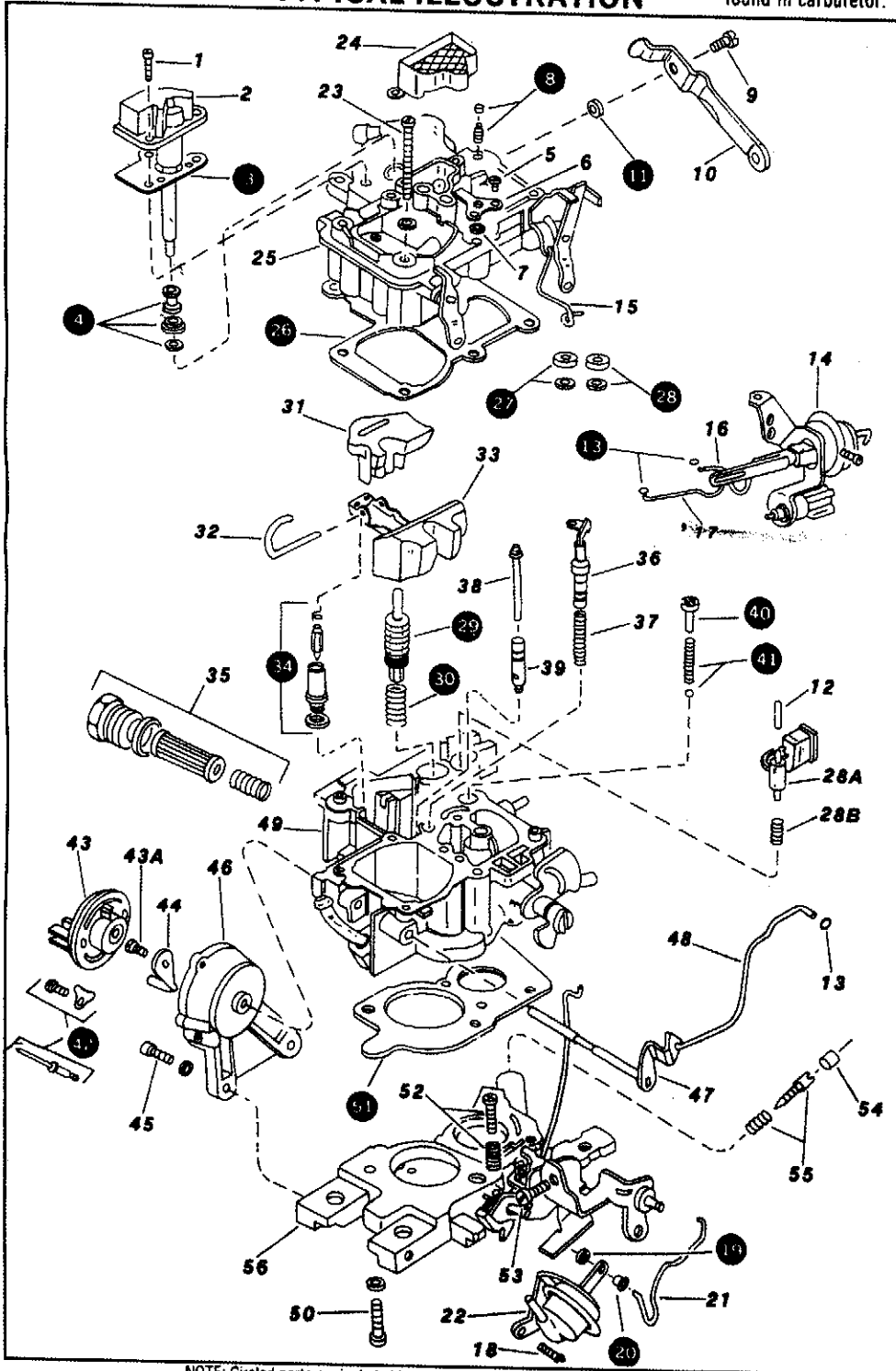

CLEANING

Cleaning must be done with carburetor disassembled. Cover opening on intake manifold after carburetor is removed. Soak parts in cleaning solvent long enough to soften foreign matter.
Caution: Do not soak parts made of rubber, leather, plastic or electrical parts. Do not use abrasives. Do not use a metal wire to clean out passageways and jets. Wash off in suitable solvent. Clear all passageways with compressed air.

PARTS LIST

1. Screw, Mixture Control Solenoid •
2. Solenoid, Mixture Control •
3. Gasket, Mixture Control Solenoid •
4. Adapter, Seal & Retainer •
5. Screw, Hot Idle Compensator
6. Hot Idle Compensator
7. Seat, Hot Idle Compensator
8. Plug & Adjusting Screw, T.P.S. •
(Screw not included in kit)
9. Screw, Pump Lever
10. Lever, Accelerator Pump
11. Spacer, Pump Lever
12. Pin, Plunger, T.P.S. •
13. Clip, Rod (2)
14. Vacuum Break, Primary
15. Rod, Fast Idle Cam
16. Rod, Vacuum Break, Primary
17. Rod, Air Valve
18. Screw, Vacuum Break, Secondary (2) •
19. Retainer, Vac. Break Rod •
20. Bushing, Vac. Break Rod •
21. Rod, Vacuum Break
22. Vacuum Break, Secondary •
23. Screw, Air Horn¹² (3 short, 4 long)
24. Stack, Vent
25. Air Horn Assy.
26. Gasket, Air Horn
27. Seal & Retainer, Pump Stem
28. Seal & Retainer, T.P.S. •
- 28A. Sensor, Throttle Positioner •
- 28B. Spring, Tension, T.P.S. •
29. Pump Assembly
30. Spring, Pump Return
31. Insert, Float Bowl
32. Retainer Rod, Float
33. Float
34. Needle, Seat & Gasket Assy.
35. Fuel Fitting, Gasket & Filter Assy.
36. Power Piston
37. Spring, Power Piston
38. Rod, Primary Metering
39. Jet, Primary
40. Guide, Pump Discharge
41. Ball & Spring, Pump Discharge
42. Screw or Rivet & Retainer, Choke Cover
43. Cover, Choke Stat
- 43A. Screw, Choke Lever
44. Lever, Choke Stat
45. Screw, Choke Housing
46. Housing, Choke
47. Shaft & Lever, Intermediate Choke
48. Rod, Intermediate Choke
49. Main Body
50. Screw, Throttle Body to Main Body
51. Gasket, Main Body to Throttle Body
52. Screw & Spring, Idle Speed
53. Screw, Fast Idle Cam
54. Plug, Hardened Steel¹³
55. Screw & Spring Idle Mixture¹³
56. Throttle Body

• Some Models

NOTE: Circled parts are included in most kits. Extra parts are included for other kits.

PARTS LIST SHOWN DOES NOT REFLECT THE CONTENTS OF THE KIT.

REMOVAL & INSTALLATION NOTES

1. Cover intake manifold after carburetor is removed.
2. Fast idle cam and screw are not removable.
3. When removing pump discharge guide (40), pull straight out. Do not pry out as damage to casting may occur.
4. Unhook fast idle cam rod (15) when removing air horn assembly.
5. Choke cover (43) is held by pop rivets. See Figure 14 if removal becomes necessary.
6. Linkage connected to vacuum break unit can be removed at one end only.
7. Refer to Figure 1 for removal of idle mixture screw (55).
8. Install parts and components in reverse order of removal.
9. Refer to Figure 2 for proper installation of needle valve (34).
10. When installing seal retainers (27, 28), lightly stake in three places.
11. Follow this procedure when installing adapter, seal and retainer (4): Install adapter and seal onto solenoid stem, then carefully drive retainer on stem using a 3/16" socket and light hammer. Leave slight clearance for seal expansion.
12. Coat seal (4), pump stem (29), and T.P.S. plunger (12) with light oil prior to installation in carburetor.
13. Install mixture control solenoid (3) on air horn, carefully aligning solenoid stem with recess in bottom of fuel bowl. Use a slight twisting motion to ensure rubber seal on stem is guided into recess to prevent distortion or damage to the rubber seal.
14. Follow service manual for final setting of mixture control.

**FIG. 1
IDLE MIXTURE SCREW PLUG REMOVAL**

NOTE: Do not remove plugs unless it's necessary to replace idle mixture screw or idle mixture passages are clogged.

1. Place throttle body on bench, manifold side up.
2. Make two parallel cuts as shown on either side of the locator point using a hacksaw. The cuts should reach down to the steel plug but should not extend more than 1/8" beyond the locator point.
3. With throttle body supported, place a flat punch near the locator point, hold it at 45° angle and drive it into the throttle body until the casting breaks away, exposing the steel plug.
4. Hold a center punch vertical and drive it into the steel plug (hardened plug will break). Remove pieces to expose idle mixture screw.

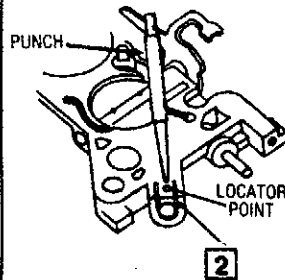

**FIG. 2
FLOAT NEEDLE & CLIP LOCATION**

NOTE: Hook clip over edge of flat on float arm in opposite direction of pontoon (as shown).

EXCEPTION: Where a damping spring is used, the clip may be hooked through one of the holes of float arm as shown.

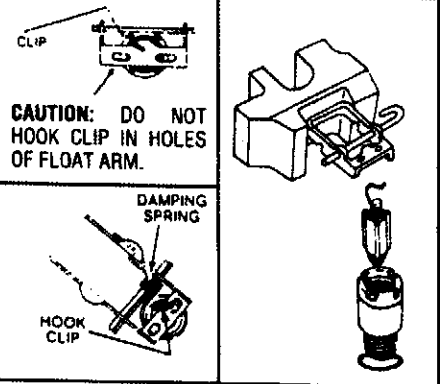

**FIG. 3
VACUUM BREAK ADJUSTMENT INFORMATION
PLUGGING AIR BLEED HOLES**

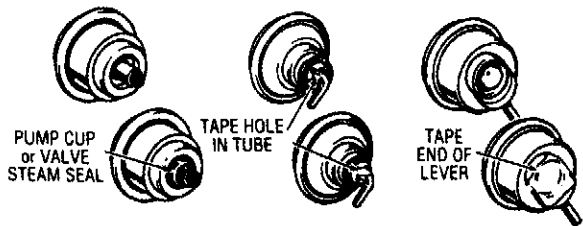

BUCKING SPRINGS

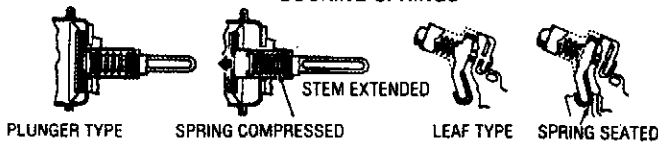

**FIG. 4
CHOKE VALVE
ANGLE GAUGE**

1. Place angle gauge magnet on closed choke valve.
2. Rotate degree scale to bring the zero mark opposite the pointer, and center the leveling bubble.
3. Rotate scale to specified angle, and open choke valve as described in adjustment steps.
4. Adjust linkage as described in adjustment steps if bubble is not in the center.

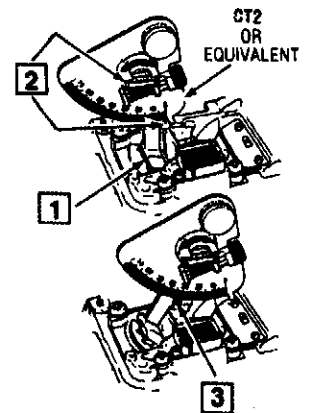

ADJUSTMENT DATA

**FIG. A
FLOAT LEVEL
ADJUSTMENT**

1. REMOVE GASKET.
2. HOLD FLOAT HINGE PIN FIRMLY IN PLACE.
3. LIGHTLY PUSH FLOAT DOWN AGAINST NEEDLE.
4. CAUTION: DO NOT ALLOW NEEDLE TO FIRMLY PRESS INTO SEAT AS AN INCORRECT SETTING WILL RESULT.
5. MEASURE AS SPECIFIED FROM TOP OF CASTING TO TOP OF FLOAT AT POINT FURTHEST AWAY FROM FLOAT HINGE.
6. TO ADJUST, REMOVE FLOAT & BEND FLOAT ARM AS NEEDED.

NOTE: AFTER ADJUSTMENT, CHECK FLOAT ALIGNMENT.

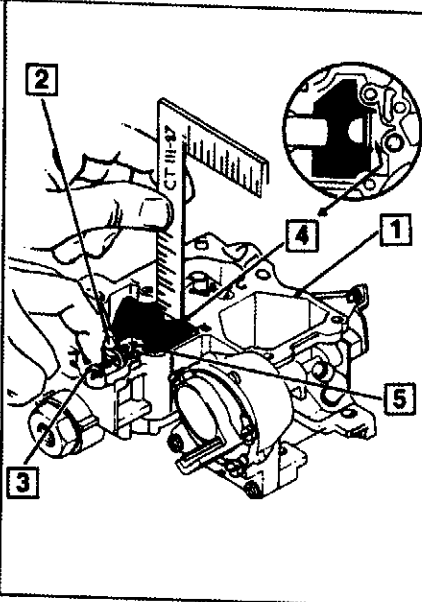

**FIG. D
CHOKE ROD
(CAM) ADJUSTMENT**

NOTE: BOTH FAST IDLE & CHOKE COIL LEVER ADJUSTMENTS MUST BE MADE FIRST BEFORE PROCEEDING. ALSO THE FOLLOWING INDICATES USE OF AN ANGLE GAUGE WITH CARB. ON OR OFF ENGINE, WITH CARB. OFF ENGINE, PLACE IN SAME POSITION IN FIXTURE WITH GAUGE IN PLACE.

1. USE CHOKE VALVE ANGLE GAUGE WITH DEGREE SCALE.
2. TURN DEGREE SCALE UNTIL ZERO IS OPPOSITE POINTER.
3. POSITION ANGLE GAUGE MAGNET ON TOP OF CLOSED CHOKE VALVE.
4. ROTATE LEVELING BUBBLE UNTIL CENTERED.
5. ROTATE SCALE SO THAT SPECIFIED DEGREE FOR ADJUSTMENT IS LINED UP WITH POINTER.
6. POSITION FAST IDLE SCREW ON 2ND STEP OF CAM.
7. MOVE INTERMEDIATE CHOKE VALVE LEVER TOWARD CLOSED CHOKE POSITION.

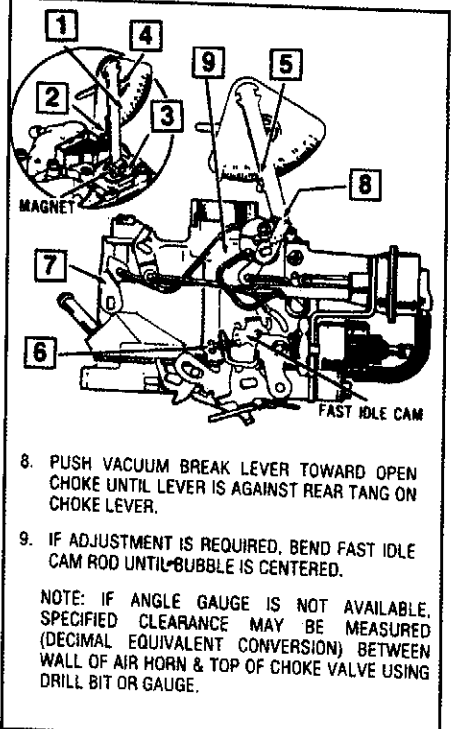

**FIG. B
PUMP
ADJUSTMENT**

NOTE: PUMP LEVER IS MADE OF HARDENED STEEL. AS A RESULT, DIFFICULT TO BEND. DO NOT BEND UNLESS ABSOLUTELY NECESSARY.

1. POSITION THROTTLE VALVES CLOSED WITH FAST IDLE SCREW OFF STEPS OF FAST IDLE CAM.
2. MEASURE AS SPECIFIED FROM TOP OF PUMP STEM TO TOP SURFACE OF AIR HORN CASTING.
3. TO ADJUST, REMOVE LEVER & PLACE IN VISE. BEND END AS REQUIRED (UP OR DOWN) NEAREST NARROW SECTION. IF ADJUSTMENT WAS CHANGED, BE SURE TO CHECK THROTTLE VALVE LINKAGE FOR FREEDOM OF MOVEMENT.

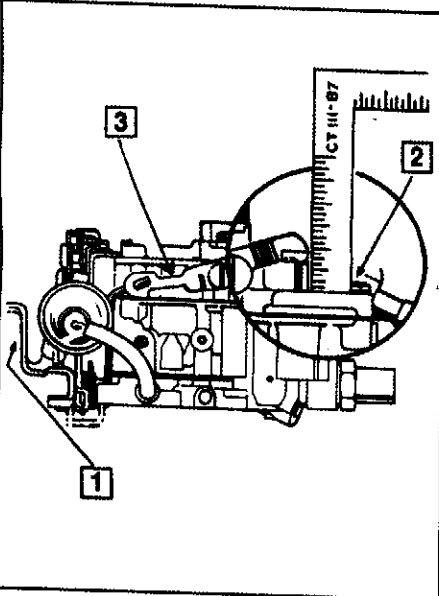

**FIG. E
CHOKE ROD
(CAM) ADJUSTMENT**

FOLLOW SAME ADJUSTMENT PROCEDURES AS OUTLINED IN FIG. D EXCEPT FOR DIFFERENT LOCATION FOR BENDING FAST IDLE CAM ROD.

1. TO ADJUST, BEND FAST IDLE CAM ROD AS SHOWN.

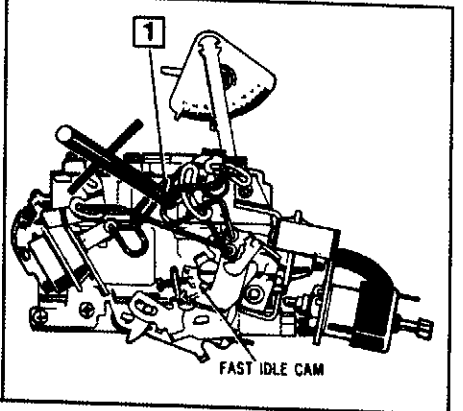

**FIG. C
CHOKE COIL
LEVER SETTING**

1. REMOVE THERMOSTATIC COVER FROM CHOKE HOUSING & PLACE FAST IDLE SCREW OF HIGH STEP OF CAM.
2. MOVE INTERMEDIATE CHOKE VALVE LEVER UNTIL CHOKE VALVE IS CLOSED.
3. MEASURE AS SPECIFIED USING GAUGE OR DRILL IN HOLE PROVIDED WHICH SHOULD BE NEXT TO THE EDGE OF LEVER AS SHOWN.
4. TO ADJUST, BEND INTERMEDIATE CHOKE ROD AT THIS POINT.

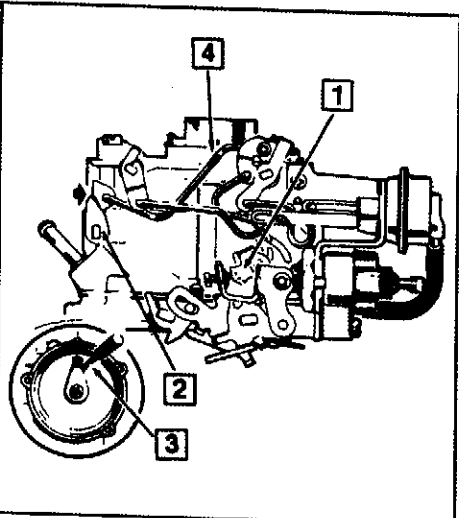

**FIG. F
AIR VALVE ROD
ADJUSTMENT (TYPICAL)**

1. USE ANGLE GAUGE WITH DEGREE SCALE & TURN DEGREE SCALE UNTIL ZERO IS OPPOSITE POINTER.
2. POSITION ANGLE GAUGE MAGNET ON TOP OF CLOSED AIR VALVE.
3. ROTATE LEVELING BUBBLE UNTIL CENTERED.
4. ROTATE SCALE SO THAT SPECIFIED DEGREE FOR ADJUSTMENT IS LINED UP WITH POINTER.
5. USING AN OUTSIDE VACUUM SOURCE, SEAT VACUUM DIAPHRAGM.
6. APPLY LIGHT PRESSURE TO AIR VALVE SHAFT IN DIRECTION OF OPEN AIR VALVE.

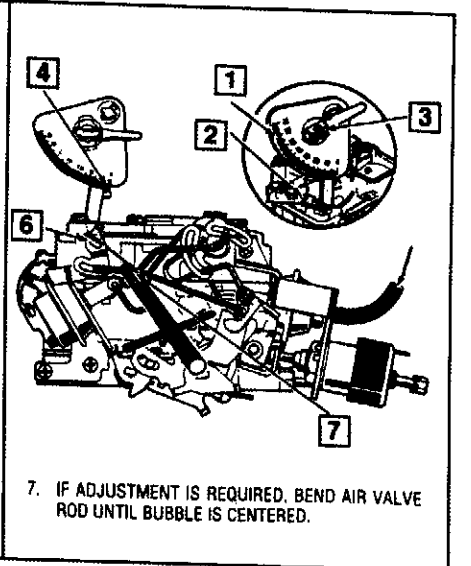

ADJUSTMENT DATA (Cont'd)

FIG. G
AIR VALVE ROD
ADJUSTMENT (L-4)

BEFORE PROCEEDING, PERFORM PRELIMINARY STEPS 1-4 AS OUTLINED IN FIG. F.

1. USING AN OUTSIDE VACUUM SOURCE, SEAT VACUUM DIAPHRAGM.

NOTE: IF PURGE BLEED HOLE IS USED, PLUG END COVER WITH TAPE. TAPE MUST BE REMOVED AFTER ADJUSTMENT.

2. APPLY LIGHT PRESSURE TO AIR VALVE SHAFT IN DIRECTION OF OPEN AIR VALVE.
3. IF ADJUSTMENT IS REQUIRED, BEND AIR VALVE ROD UNTIL BUBBLE IS CENTERED.

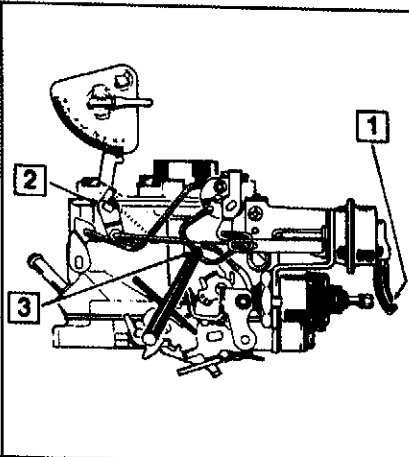

FIG. K
VACUUM BREAK
SECONDARY (TYPICAL)

BEFORE PROCEEDING, PERFORM PRELIMINARY STEPS 1-4 AS OUTLINED IN FIG. D.

1. ROTATE SCALE SO THAT SPECIFIED DEGREE FOR ADJUSTMENT IS LINED UP WITH POINTER.
2. USING VACUUM SOURCE, SEAT CHOKE VACUUM DIAPHRAGM.

NOTE: IF PURGE BLEED HOLE IS USED, PLUG END COVER WITH TAPE. TAPE MUST BE REMOVED AFTER ADJUSTMENT.

3. PUSH ON INTERMEDIATE CHOKE LEVER TO LIGHTLY CLOSE CHOKE.
4. IF ADJUSTMENT IS REQUIRED, BEND VACUUM BREAK ROD UNTIL BUBBLE IS CENTERED.

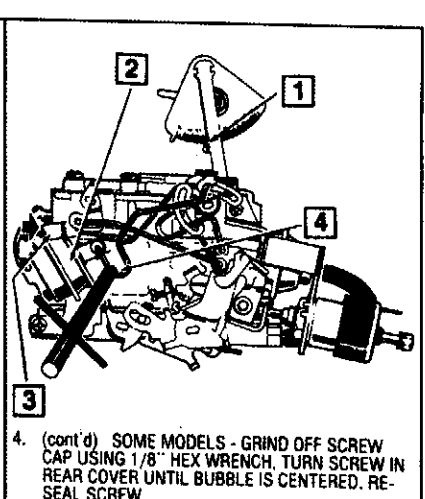

FIG. H
VACUUM BREAK
PRIMARY (TYPICAL)

PROCEEDING, PERFORM PRELIMINARY STEPS 1-4 AS OUTLINED IN FIG. D.

1. ROTATE SCALE SO THAT SPECIFIED DEGREE FOR ADJUSTMENT IS LINED UP WITH POINTER.
2. USING VACUUM SOURCE, SEAT CHOKE VACUUM DIAPHRAGM.
3. PUSH ON INTERMEDIATE CHOKE LEVER TO CLOSE CHOKE VALVE.
4. IF ADJUSTMENT IS REQUIRED, BEND VACUUM BREAK ROD UNTIL BUBBLE IS CENTERED.

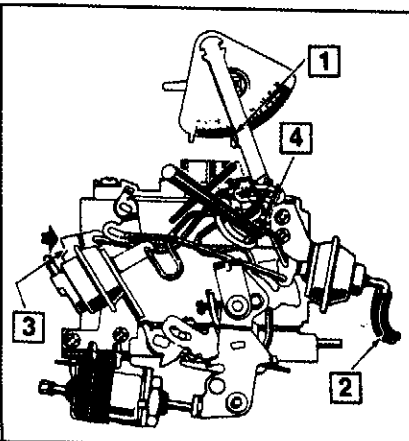

FIG. L
UNLOADER
ADJUSTMENT (TYPICAL)

BEFORE PROCEEDING, PERFORM PRELIMINARY STEPS 1-4 AS OUTLINED IN FIG. D.

1. ROTATE SCALE SO THAT SPECIFIED DEGREE FOR ADJUSTMENT IS LINED UP WITH POINTER. NEXT, INSTALL CHOKE COVER & SET SCRIBED LINE WITH SPECIFIED MARK ON CHOKE HOUSING.
2. MAINTAIN THROTTLE VALVE IN WIDE OPEN POSITION.
3. WITH ENGINE WARMED-UP, PUSH CLOCKWISE ON INTERMEDIATE CHOKE LEVER TO CLOSE CHOKE VALVE. HOLD IN POSITION WITH RUBBER BAND.
4. IF ADJUSTMENT IS REQUIRED, BEND TANG UNTIL BUBBLE IS CENTERED.

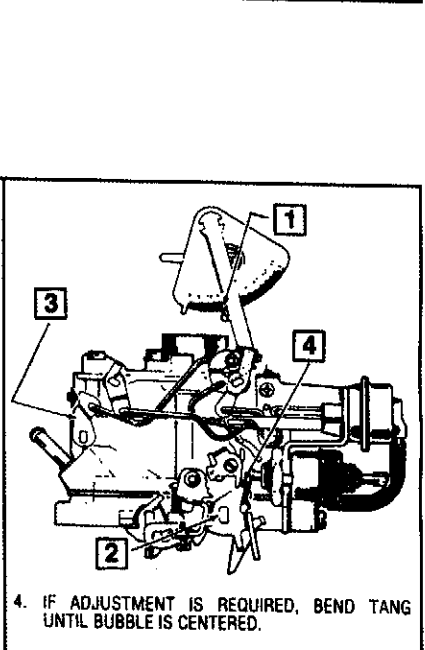

FIG. I
VACUUM BREAK
PRIMARY (PASS. L-4)

BEFORE PROCEEDING, PERFORM PRELIMINARY STEPS 1-4 AS OUTLINED IN FIG. D.

1. ROTATE SCALE SO THAT SPECIFIED DEGREE FOR ADJUSTMENT IS LINED UP WITH POINTER.
2. USING VACUUM SOURCE, SEAT CHOKE VACUUM DIAPHRAGM.

NOTE: IF PURGE BLEED HOLE IS USED, PLUG END COVER WITH TAPE. TAPE MUST BE REMOVED AFTER ADJUSTMENT.

3. PUSH ON INTERMEDIATE CHOKE LEVER TO CLOSE CHOKE VALVE. BE SURE PLUNGER BUCKING SPRING (IF USED) IS COMPRESSED & SEATED.
4. IF ADJUSTMENT IS REQUIRED, BEND VACUUM BREAK ROD UNTIL BUBBLE IS CENTERED.

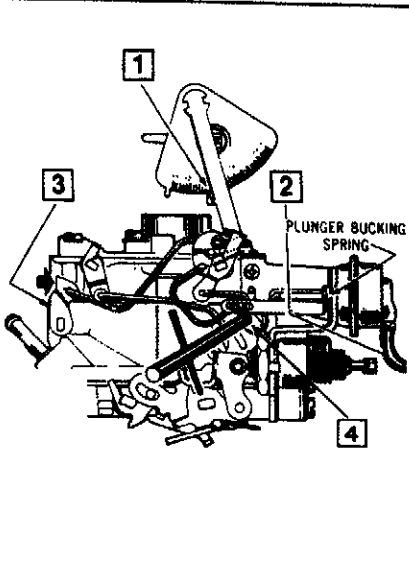

FIG. M
AUTO CHOKE
ADJUSTMENT

NOTE: POSITION FAST IDLE SCREW ON HIGH STEP OF FAST IDLE CAM.

1. LOOSEN 3 HOLD-DOWN SCREWS. NOTE: SOME MODELS HAVE CHOKES WHICH DO NOT REQUIRE ADJUSTMENT. HOWEVER, IF DISASSEMBLY BECOMES NECESSARY, SCRIBE A REFERENCE LINE FROM CHOKE COVER TO HOUSING THEN DRILL OUT RIVETS USING A NO. 21 DRILL (1.59"). REASSEMBLE TO REFERENCE MARK USING SIMILAR RIVETS OR APPROPRIATE SIZE SHEET METAL OR SELF-TAPPING SCREWS.
2. POSITION SCRIBE LINE ON ELECTRIC CHOKE TO SPECIFIED MARK ON CHOKE HOUSING. CHOKE VALVE MUST BE SPRING-LOADED TOWARD CLOSED POSITION.

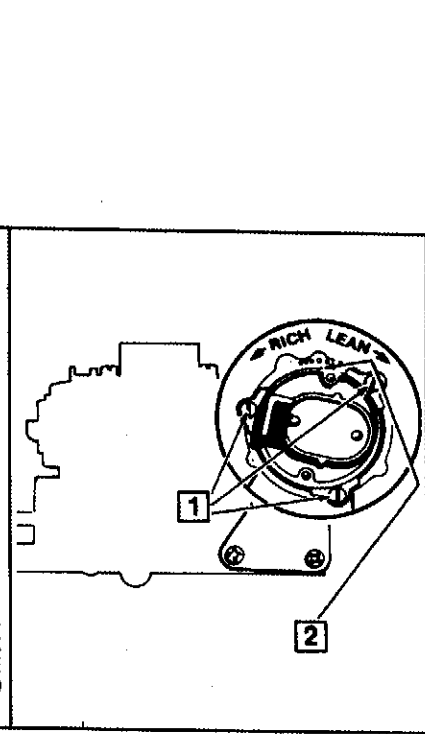
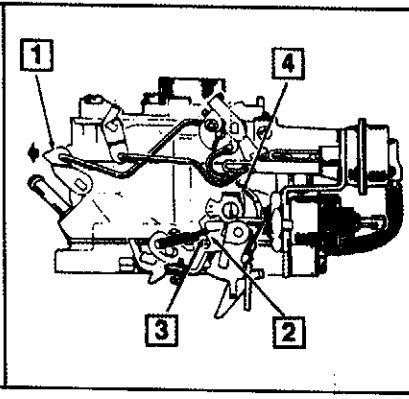

FIG. J
SECONDARY LOCKOUT
ADJUSTMENT

1. PUSH COUNTERCLOCKWISE ON INTERMEDIATE CHOKE LEVER TO MAINTAIN CHOKE VALVE WIDE OPEN.
2. OPEN THROTTLE LEVER UNTIL END OF SECONDARY ACTUATING LEVER IS OPPOSITE TOE OF LOCKOUT LEVER.
3. USING GAUGE OR DRILL MEASURE CLEARANCE AS SPECIFIED.
4. IF ADJUSTMENT IS REQUIRED, BEND LOCKOUT LEVER TANG CONTACTING FAST IDLE CAM.



SPECIFICATIONS BY APPLICATION

Year	MODEL	Float Level Adj.	Pump Adj.	Choke Lever Adj.	Choke Coil Fig.	Choke Rod Cam Adj.	Air Valve Rod Adj.	Fig.	Vacuum Break		Unloader Adj.	Auto Choke Adj.	Fig.	Sec. Lockout	Fig.			
									Primary Fig.	Secondary Fig.								
GM TRUCKS—SPECIFICATION I.D. - A																		
1983	250 Eng. - Fed. -Carb. Nos. 17083423, 29; 560, 62, 65, 69	3/16"	*	3/32"	C	15°	1°	F	26 ⁰³	H	38°	K	42°	L	T.R.	M	.025"	J
1982	250 Eng. - Cal. -Fed. -Carb. Nos. 17082431, 33 -Carb. No. 17082482 -Carb. Nos. 17082486, 87, 88, 89	3/16"	*	3/32"	C	15°	1°	F	28°	H	37°	K	42°	L	T.R.	M	.025"	J
		3/16"	*	5/64"	C	15°	1°	F	30°	H	38°	K	42°	L	T.R.	M	.025"	J
		3/16"	*	5/64"	C	15°	1°	F	26°	H	38°	K	42°	L	T.R.	M	.025"	J
		3/16"	*	5/64"	C	15°	1°	F	24°	H	38°	K	42°	L	T.R.	M	.025"	J
1981	250 Eng. - Fed. -Cal. 250 Eng. - (C, 6, 10, 15, 20, 25, K, 10, 15)	3/16"	*	5/64"	C	15°	1°	F	28°	H	38°	K	42°	L	T.R.	M	.025"	J
		3/16"	5/8"	5/64"	C	15°	1°	F	26 ⁰⁷	H	38 ⁰⁷	K	38°	L	T.R.	M	.025"	J
		3/16"	5/8"	5/64"	C	15°	1°	F	30°	H	37°	K	40°	L	T.R.	M	.025"	J
1979	250 Eng. - Cal. - (C, G, 10, 15, 20, 25) -A.T. -M.T. -Fed. - (C, G, 10, 15, 20, 25; 6, 30, 35)	1/8"	9/16"	3/32"	C	17°	2°	F	22 ⁰⁴	H	35°	K	41°	L	T.R.	M	.025"	J
		1/8"	9/16"	3/32"	C	17°	2°	F	20°	H	37°	K	49°	L	1NR	M	.025"	J
		1/8"	9/16"	3/32"	C	17°	2°	F	23 1/2°	H	37°	K	49°	L	2NR	M	.025"	J
1984	250 Eng. -Carb. Nos. 17084410, 12 -Carb. Nos. 17084425, 27 -Carb. Nos. 17084560, 62, 69	1/4"	*	3/32"	C	24°	1°	F	30°	H	37°	K	30°	L	T.R.	M	.025"	J
		1/4"	17/32"	3/32"	C	24°	1°	F	30°	H	38°	K	30°	L	T.R.	M	.025"	J
		1/4"	17/32"	3/32"	C	24°	1°	F	30°	H	38°	K	30°	L	T.R.	M	.025"	J
		1/4"	17/32"	3/32"	C	24°	1°	F	30°	H	37°	K	30°	L	T.R.	M	.025"	J
BUICK, CHEVROLET, OLDSMOBILE & PONTIAC—SPECIFICATION I.D. - B																		
1984	250 Eng. -Carb. Nos. 17084410, 12 -Carb. Nos. 17084425, 27 -Carb. Nos. 17084560, 62, 69	1/4"	*	3/32"	C	15°	1°	F	23°	H	38°	K	42°	L	T.R.	M	.025"	J
		1/4"	*	3/32"	C	15°	1°	F	26°	H	36°	K	40°	L	T.R.	M	.025"	J
		1/4"	*	3/32"	C	15°	1°	F	24°	H	34°	K	38°	L	T.R.	M	.025"	J
GM TRUCKS (Series CK, G)																		
1980	173 Eng. - Cal. - M.T. -A.T. - w/A.C. ¹³ -A.T. - w/A.C. -w/O A.C.	1/8"	15/32"	3/32"	C	16°	2°	F	20°	H	33°	K	35°	L	T.R.	M	.025"	J
		1/4"	*	5/64"	C	16°	1°	F	24°	H	32.5°	K	35°	L	T.R.	M	.025"	J
		1/8"	15/32"	3/32"	C	16°	2°	F	20°	H	33°	K	35°	L	T.R.	M	.025"	J
BUICK, CHEVROLET OLDSMOBILE & PONTIAC—SPECIFICATION I.D. - D																		
1980	151 Eng. - Cal. -M.T.	7/32"	A	3/32"	C	25°	2°	G	20°	I	---	---	32°	L	T.R.	M	.025"	J
		5/32"	A	3/32"	C	18°	1°	F	19°	H	---	---	32°	L	T.R.	M	.025"	J
		5/32"	A	3/32"	C	18°	1°	F	21°	H	---	---	32°	L	T.R.	M	.025"	J
AMC, JEEP—SPECIFICATION I.D. - E																		
80-79	151 Eng. - Cal. - A.T. -M.T.	5/32"	A	3/32"	C	18°	1°	F	19°	H	---	---	32°	L	T.R.	M	.025"	J
		5/32"	A	3/32"	C	18°	1°	F	21°	H	---	---	32°	L	T.R.	M	.025"	J
		5/32"	A	3/32"	C	18°	1°	F	21°	H	---	---	32°	L	T.R.	M	.025"	J

SPECIFICATIONS BY APPLICATION (Cont'd)

Year	MODEL	Float Level Adj.	Pump Adj.	Choke Coil Lever Adj.	Choke Rod Cam Adj.	Air Valve Red Adj.	Vacuum Break Primary Fig.	Vacuum Break Secondary Fig.	Unloader Adj.	Auto Choke Adj.	Fig.	Sec. Lockout	Fig.
85-82 1981	AMC, JEEP—SPECIFICATION I.D. - F 151 Eng. - Calif. 151 Eng. - Calif.	1/8"	*	5/64"	18°	1°	19°	—	34°	T.R.	L	.025"	J
		1/8"	*	5/64"	25°	1°	19°	—	34°	T.R.	L	.025"	J
1981	BUICK, CHEVROLET, OLDSMOBILE, PONTIAC 151 Eng. - U.S. - A.T. -M.T.	1/8"	*	3/32"	18°	1°	19°	—	32°	T.R.	L	.025"	J
		1/8"	*	3/32"	33.5°	1°	21°	—	32°	T.R.	L	.025"	J
1981	BUICK, CHEVROLET, OLDSMOBILE & PONTIAC—SPECIFICATION I.D. - H 2.8X Eng. - M.T. -A.T. Exc. as noted below -Carb. # 17081656.58 -Carb. # 17081616.18 -Carb. # 17081608.10.12 2.8X Eng. - A.T., A.C. - Cal.	1/4"	*	5/64"	17°	1°	29°	35°	35°	I.R.	L	.025"	J
		1/4"	*	5/64"	17°	1°	25°	35°	35°	I.R.	L	.025"	J
1983	BUICK, CHEVROLET, OLDSMOBILE & PONTIAC—SPECIFICATION I.D. - I 2.8X Eng. 2.8X, Z Eng. 2.8 Eng. - A.T. Closed Loop -M.T. Closed Loop	1/4"	*	5/64"	28°	1°	27°	35°	45°	T.R.	L	.025"	J
		1/4"	*	5/64"	28°	1°	27°	35°	45°	T.R.	L	.025"	J
1982	GM TRUCKS 1.1L Eng. - Cal. 2.8 Eng.	5/16"	*	5/64"	18°	1°	23°	27°	35°	T.R.	L	.025"	J
		5/16"	*	5/64"	18°	1°	21°	27°	35°	T.R.	L	.025"	J
1984 83-82	GM TRUCKS 1.1L Eng. - Cal. 2.8 Eng.	11/32"	*	3/32"	15°	1°	26°	38°	42°	T.R.	L	.025"	J
		13/32"	*	5/64"	22°	1°	25°	35°	30°	T.R.	L	.025"	J
1983	BUICK, CHEVROLET, OLDSMOBILE & PONTIAC—SPECIFICATION I.D. - K 2.87 Eng. - A.T. - A.I.R. w/A.C. 2nd Design	1/8"	*	5/64"	28°	1°	27°	35°	45°	T.R.	L	.025"	J
		1/8"	*	5/64"	28°	1°	27°	35°	45°	T.R.	L	.025"	J
1984	CHEVROLET & GMC TRUCKS (Series S1, ST1)—SPECIFICATION I.D. - L 2.8L Eng. - A.T., M.T. Cal. Carb. Nos. 17084356, 357, 358, 359	9/32"	*	5/64"	22°	1°	25°	30°	30°	T.R.	L	.025"	J
		9/32"	*	5/64"	22°	1°	25°	30°	30°	T.R.	L	.025"	J
1982	BUICK, CADILLAC, CHEVROLET, OLDSMOBILE & PONTIAC—SPECIFICATION I.D. - M 1.8L Eng. - Carb. No. 17059327	5/16"	*	5/64"	18°	1°	23°	27°	35°	T.R.	L	.025"	J
		5/16"	*	5/64"	18°	1°	23°	27°	35°	T.R.	L	.025"	J
84-83	BUICK, CHEVROLET, OLDSMOBILE & PONTIAC 2.0L Eng. - A.T., M.T. Exp. - Can. Carb. No. 17083314 Carb. No. 17083401 Carb. No. 17084312 Carb. No. 17084314	5/16"	*	5/64"	24°	1°	16°	20°	35°	T.R.	L	.025"	J
		5/16"	*	5/64"	24°	1°	18°	20°	35°	T.R.	L	.025"	J

SPECIFICATIONS BY APPLICATION (Cont'd)

Year	MODEL	Float Level Adj.	Pump Adj.	Choke Coil Lever Adj.	Choke Red Cam Adj.	Air Valve Rod Adj.	Vacuum Break		Unloader Adj.	Auto Choke Adj.	Sec. Lockout Fig.							
							Primary Fig.	Secondary Fig.										
BUICK, CHEVROLET, OLDSMOBILE & PONTIAC -- SPECIFICATION I.D. - M (cont'd)																		
1982	1.8L Eng. - A.T., M.T. Exp. - Can. Carb. Nos. 17082310, 312, 314 Carb. Nos. 17082311, 315 Carb. Nos. 17082400, 401, 402, 404, 405	5/16" 5/16" 5/16"	A A A	B B B	C C C	E E E	1° 1° 1°	F F F	17° 20° 20°	H H H	22° 24° 24°	K K K	35° 35° 35°	L L L	T.R. T.R. T.R.	M M M	.025" .025" .025"	J J J
GM TRUCKS (Series S1, ST1)																		
1983	2.0L Eng. - A.T., M.T. Alt., Fed. Carb. Nos. 17083390, 391, 392, 393, 394, 395, 396, 397	13/32"	A	B	C	E	1°	F	30°	H	35°	K	38°	L	T.R.	M	.025"	J
BUICK, CHEVROLET, OLDSMOBILE & PONTIAC -- SPECIFICATION I.D. - O																		
1986	2.8L Eng. - Exp. & Can. Carb. Nos. 17086484, 485	3/8"	A	B	C	E	1°	F	28°	H	32°	K	45°	L	T.R.	M	.025"	J
1985	2.8L Eng. Carb. Nos. 17055484, 485	3/8"	A	B	C	E	1°	F	28°	H	32°	K	45°	L	T.R.	M	.025"	J
1984	2.8L Eng. - Can. Carb. Nos. 17084480, 481, 482, 483, 484, 485	1/4"	A	B	C	E	1°	F	28°	H	32°	K	45°	L	T.R.	M	.025"	J
1983	2.8L Eng. - Carb. Nos. 17083440, 441, 442, 443, 444, 445 Carb. Nos. 17083620, 621, 622, 623	7/16"	A	B	C	E	1°	F	28°	H	32°	K	40°	L	T.R.	M	.025"	J
1982	2.8L Eng. - Carb. Nos. 17083440, 441, 442, 443 -Carb. Nos. 17082620, 621, 622, 623	1/4" 7/16"	A A	B B	C C	E E	1° 1°	F F	30° 30°	H H	32° 32°	K K	45° 45°	L L	T.R. T.R.	M M	.025" .025"	J J
GM TRUCKS (Series S1 T1, ST1)																		
1985	2.8L Eng. - A.T., M.T. Alt., Fed. Carb. Nos. 17083348, 350, 352, 354, 360, 362, 364, 366, 372, 374	5/32"	A	B	C	E	1°	F	32° ⁰⁹	H	36° ¹⁰	K	40°	L	T.R.	M	.025"	J
1984	2.0L Eng. - Fed., Alt. Carb. Nos. 17084390, 391, 392, 393	7/16"	A	B	C	E	1°	F	30°	H	38°	K	38°	L	T.R.	M	.025"	J
1984	2.8L Eng. - A.T. Alt., Fed. Carb. Nos. 17084360, 362, 364, 366	5/32"	A	B	C	E	1°	F	30°	H	32° ¹¹	K	40°	L	T.R.	M	.025"	J
1983	2.8L Eng. - Exc. Cal. w/o A.C. -Carb. Nos. 17083348, 349, 351 -Carb. Nos. 17083352, 353 -Carb. No. 17083360 -Carb. No. 17083364 -w/A.C. - Carb. No. 17083350 -Carb. Nos. 17083354, 355	7/16" 7/16" 5/32" 5/32" 7/16"	A A A A A	B B B B B	C C C C C	E E E E E	1° 1° 1° 1° 1°	F F F F F	30° 30° 30° 30° 30°	H H H H H	32° 35° 32° 32° 35°	K K K K K	40° 40° 40° 40° 40°	L L L L L	T.R. T.R. T.R. T.R. T.R.	M M M M M	.025" .025" .025" .025" .025"	J J J J J
198	2.8L Eng. - Exc. Cal. -Carb. Nos. 17082348, 349, 350, 351 -Carb. Nos. 17082353, 355	7/16" 7/16"	A A	B B	C C	E E	1° 1°	F F	30° 30°	H H	32° 35°	K K	40° 40°	L L	T.R. T.R.	M M	.025" .025"	J J

SPECIFICATIONS BY APPLICATION (Cont'd)

Year	MODEL	Float Level Adj.	Pump Adj.	Choke Coil Lever Adj.	Choke Rod Cam Adj.	Air Valve Rod Adj.	Vacuum Break		Unloader Adj.	Auto Choke Adj.	Sec. Lockout									
							Primary Fig.	Secondary Fig.												
86-84	2.8L Eng.	5/32"	A	* B	5/64"	C	22°	E	1°	G	26°	H	32°	K	40°	L	T.R.	M	.025"	J

JEEP - SPECIFICATION I.D.-O (cont'd)

ABBREVIATIONS:

- A.C. Air Conditioning
- A.I.R. Air Induction Reactor
- All. Altitude
- A.T. Automatic Transmission
- Cal. California
- Can. Canada
- Exc. Export
- Fed. Federal Emission Standards
- Hi. Alt. High Altitude
- M.T. Manual Transmission
- M.R. Notches Rich
- T.R. Tamper Resistant
- T.P.S. Throttle Position Sensor
- Vac. Vacuum

FOOTNOTES:

- * Non-adjustable
- 1 Carb. Nos. 17059721, 22, 23, 24 set 18° for early production (before 4/30/80); set 33° for late production (after 4/30/80).
- 2 Carb. Nos. 17082388, 389 set 7/32"
- 3 Carb. Nos. 17083410, 416 set 23°
- 4 Carb. Nos. 17080720, 722 set 20°
- 5 Carb. Nos. 17080721 set 23 1/2°
- 6 Carb. Nos. 17059666, 67 set 26°
- 7 Carb. No. 17081629 set Primary 24°, Secondary 34°.
- 8 Carb. No. 17081629 set 41°
- 9 Carb. No. 17085352, 54, 64, 66 set 30°
- 10 Carb. Nos. 17085352, 54, 64, 66 set 34°
- 11 Carb. Nos. 17084364, 66 set 35°
- 12 One screw hidden under Hot Idle Compensator.
- 13 Carb. Nos. 17067005; 17080740

ANGLE DEGREE TO DECIMAL CONVERSION

THE RELATION BETWEEN DECIMAL AND ANGLE READINGS IS NOT EXACT DUE TO MANUFACTURING TOLERANCES. THIS CHART IS SUPPLIED FOR THOSE WHO HAVE ACCESS TO DRILL BITS OR PLUG GAUGES ONLY. NOTE: BE SURE TO MEASURE BETWEEN UPPER EDGE OF CHOKE VALVE AND WALL OF AIR HORIN. GENERAL MOTORS RECOMMENDS USING AN ANGLE GAUGE FOR BEST OVERALL PERFORMANCE AND ACCURACY.

ANGLE DEGREES	DECIMAL EQUIV. TOP OF VALUE	ANGLE DEGREES	DECIMAL EQUIV. TOP OF VALUE	ANGLE DEGREES	DECIMAL EQUIV. TOP OF VALUE	ANGLE DEGREES	DECIMAL EQUIV. TOP OF VALUE	ANGLE DEGREES	DECIMAL EQUIV. TOP OF VALUE	ANGLE DEGREES	DECIMAL EQUIV. TOP OF VALUE	ANGLE DEGREES	DECIMAL EQUIV. TOP OF VALUE	ANGLE DEGREES	DECIMAL EQUIV. TOP OF VALUE
5	.023	13	.066	21	.117	29	.171	37	.234	45	.304	53	.379	61	.449
6	.028	14	.071	22	.123	30	.179	38	.243	46	.314	54	.388	62	.464
7	.033	15	.077	23	.129	31	.187	39	.251	47	.322	55	.400	63	.481
8	.038	16	.083	24	.136	32	.195	40	.260	48	.332	56	.408	64	.493
9	.043	17	.090	25	.142	33	.203	41	.269	49	.341	57	.418	65	.506
10	.049	18	.096	26	.149	34	.211	42	.277	50	.350	58	.428	66	.522
11	.054	19	.103	27	.157	35	.220	43	.287	51	.360	59	.439	67	.539
12	.060	20	.110	28	.164	36	.227	44	.295	52	.370	60	.449	68	.550