

STABILILUS

Gas Springs and Dampers

for Automotive Applications

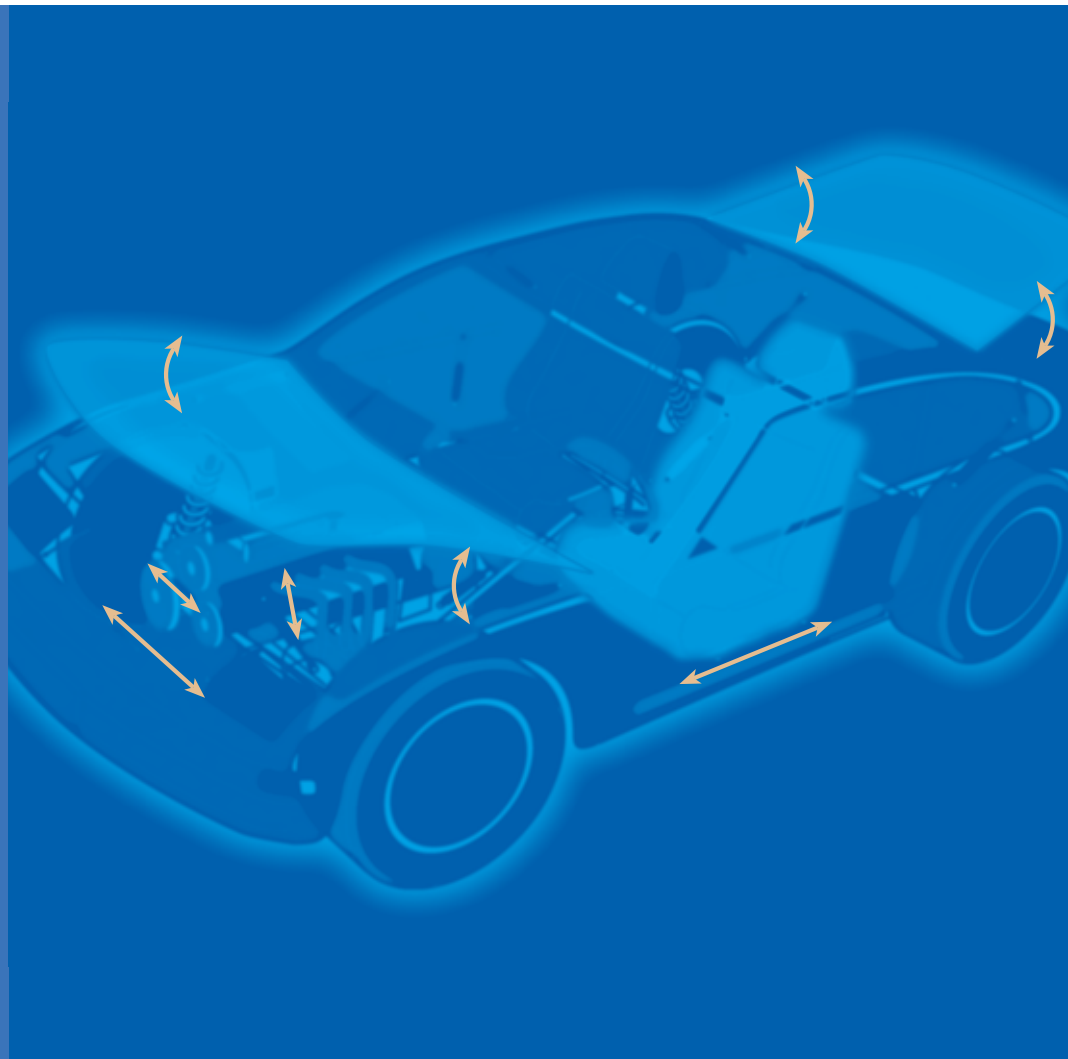

. . . t e c h n o l o g y g i v e s c o m f o r t

STABILUS – A Company with Innovative Tradition



State of the art Product development



Stabilus designs and builds all of its own production machinery



Continuous quality control in our own test labs



Optimum training in our own training centers

Pioneer Performance

Ever since the company was founded in Koblenz in 1934, STABILUS has been involved in hydraulic damping elements for automotive applications. For example, the first horizontally acting damper was used as a steering damper in millions of applications. In 1962, STABILUS presented the first gas spring manufactured in series production in the world. To date, more than 1.2 billions of those have been produced. With its gas spring and hydraulic vibration damper product lines, STABILUS is the world market leader with an annual production of more than 100 million units.

Worldwide Activities

With a global sales and service network and 10 production sites in Europe, USA, Mexico, Brazil, New Zealand, Australia and Korea, STABILUS supplies and serves more than 2,000 customers worldwide.

Customer Satisfaction

Customer requirements and satisfaction, development know-how, speed, and service are major company goals. STABILUS is known for technical innovation, quality, and competitive pricing at all levels.

Gas Springs and Dampers for Automotive Applications

Highest quality, sound know-how, user-specific coordination and a high level of functional comfort provide new opportunities for installing STABILUS products in automobiles.

e.g., trunk lid...

Gas springs make opening and closing the trunk lid or tailgate safe and easy, with a defined speed curve.

e.g., hood...

Hoods open easily with the help of gas springs; they replace awkward hood props and prevent dirty hands.

e.g., seat adjustment...

Whether seat height, seat position, or back rest adjustment, gas springs and dampers provide comfort and safety.

e.g., vibration damping...

Dampers used as steering dampers or as belt tensioning dampers provide the desired smooth running, safety and comfort.

Development Supplier

For decades, STABILUS has been supplying the international automotive industry as a recognized development supplier. The service ranges from support in the area of design and development, including all customary CAD activities and standard-compliant specification processes, to excellent development and coordination support through efficient and fast sample design.

Highest Quality

As the leading gas spring supplier worldwide, our quality management system certainly fulfills the high quality requirements of international standards, such as DIN EN ISO 9001 and the new world standard ISO/TS 16949 including the requirements as per QS 9000, VDA 6.1, EAQF and AVSQ.

Protected Environment

Our production processes make environmentally friendly manufacturing a high priority. Its success is documented by the successful certification of the environment management system in compliance with DIN EN ISO 14001.

Logistics Partner

The highest level of flexibility is needed if a supplier is to fulfill the requirements resulting from the just-in-time philosophy of the automotive industry. For years, STABILUS has been practicing this very successfully and uses state-of-the-art production and communication systems for efficient coordination with our partners at all levels.

Choosing and Selecting Gas Springs

Function of Your Choice

In automotive applications, most gas springs are specially matched and selected for each vehicle model. The function of the gas spring and the comfort of the application are determined by many characteristics, which can be accurately defined prior to series introduction.

Naturally, STABILUS application engineers are ready to support and consult, drawing on their many years of experience, their combined know-how, and customized samples. The most important of these variables are presented here:

Extension Force

For gas springs to open an application easily and to close it safely, their extension force must be matched accurately. For example, if the force of the gas spring is too low, the hand force required by the user becomes uncomfortably high and may not hold the application in the open position. The extension force depends directly on the weight of the hood, the center of gravity points, as well as the link points of the gas spring.

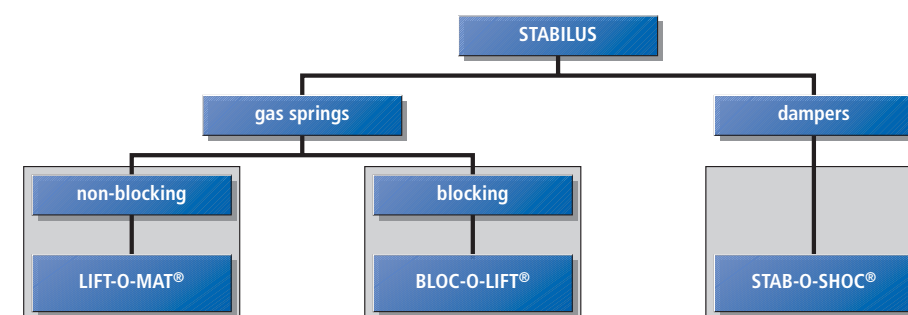

Dimensions

The diameter and the length of the gas spring are determined by its extension force and the required stroke. By varying the mounting orientation, it can be matched optimally to the installation space available.

Colour and Material

Most gas springs used in automotive applications are unobtrusive black. However, for weight reduction purposes the gas springs can be manufactured in polished aluminum for a high-tech look.

End Fittings

To ensure optimized and cost-effective mounting, and to take full advantage of the installation space while ensuring the required angle movement, different end fittings can be selected.

Speed Curve and Damping

A special characteristic of the gas spring is damping. Damping can be used to determine a specific speed curve, for example for the trunk lid. When and how strongly the damping action should work can be established individually.

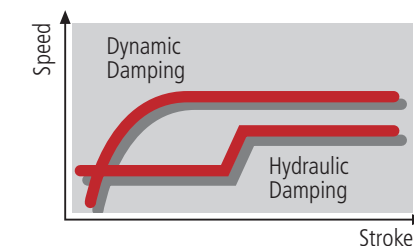

Additional Possibilities

In addition to their force-supplying and damping functions, gas springs can be equipped with additional features. For example, an end position stop protects against accidental closing, and a telescoping tube makes it possible to open the hood to a service position that is beyond the normal opening angle, just to name a few examples.



Small Selection of Available End Fittings

Non-lockable LIFT-O-MAT® Gas Springs

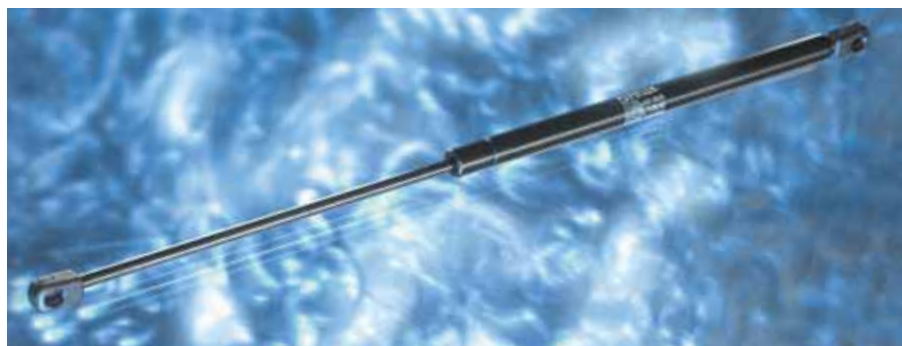

Lifting, Lowering, Moving, and Adjusting

With accurately defined extension force and user-specific damping, the LIFT-O-MAT® gas spring provides optimum weight equalization, supports forces, lifts heavy loads, and swings lids and hoods. With its damping characteristics it ensures user-friendly movements.

Properties and Advantages

- Numerous sizes and force variants are available as standard products
- Linear spring characteristics for even force increase across the entire range of movement
- Upon request, progressive or decreasing spring characteristics for force supply at the beginning or end of the stroke
- Available with dynamic or hydraulic damping, depending on the application and installation orientation
- Different end fitting systems for fast and easy mounting
- For operating temperatures between -30°C and +80°C

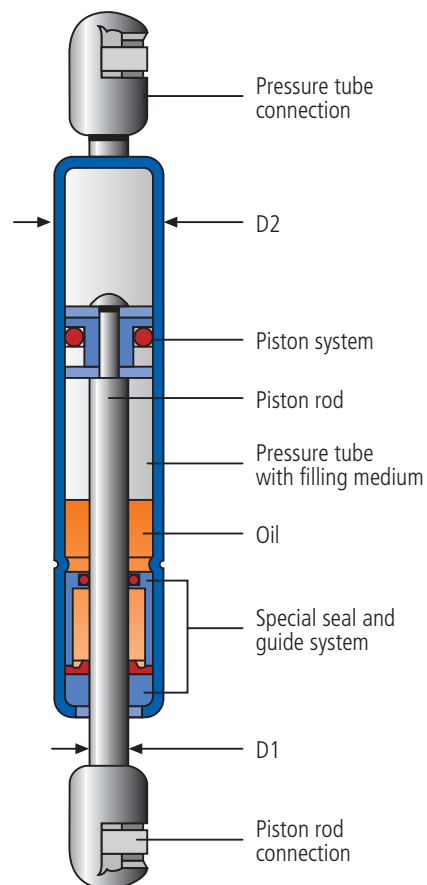

Product Variants

- **End position stop:** This mechanical end position stop, which can be located on the outside or inside, provides additional protection against accidental closing of trunk lids
- **Hydro-Lift®:** In addition to the normal LIFT-O-MAT® function, the movement can be stopped in several positions
- **LIFT-O-MAT® high friction:** Due to increased friction, these gas springs can be stopped in any position
- **Electro-Lift:** In addition to the gas spring function, electricity is transmitted or even switched on, for example to illuminate the engine compartment or the trunk.
- **Inter-STOP®:** By dividing the stroke into different functional ranges, it is possible to manually hold/ stop the application, such as the trunk lid, in several positions.

Standard Series Program			
Piston rod diameter (mm)	Pressure tube outside diameter D2 (mm)	Extension force (N)	Max. stroke (mm)
6	15	50-400	150
8	19	100-800	250
10	22	150-1150	400
14	28	500-2100	500
20	42	2400-5200	500

Dampers and STAB-O-SHOC®



Hydraulic Vibration Damping

Dampers are used to influence the properties of movements and vibrations in a positive manner. They are matched to the individual application. Oil hydraulic dampers consist of a pressure cylinder, a piston rod with piston system and end fittings. During a movement, the filling medium – the oil – is forced through specifically dimensioned bores in the piston, thus creating the desired damping force.

Properties and Advantages

- Compact dimensions with high reliability and a long service life
- For operating temperatures between -30°C and +80°C
- Pre-defined linear, progressive, or decreasing damping characteristics for optimized results
- Position-controlled damping rate; e.g., for steering dampers and driver seat dampers
- Frequency-controlled damping characteristics
- Electrically adjustable dampers
- Different end fittings for easy mounting



Product Line

- Dampers are matched to the specific requirements of the application and their design is optimized
- For orientation-independent or orientation-specific mounting
- As dampers with and without extension force
- With damping forces in one direction, or in extension and compression direction
- Upon request, vibration damping only at certain frequencies (frequency-controlled damping)

Locking Gas Springs – BLOC-O-LIFT®



Variable Positioning, Rigid or Spring Locking

BLOC-O-LIFT® gas springs work according to the same principle as the LIFT-O-MAT® gas springs. In addition, the BLOC-O-LIFT® gas springs can be locked in any position, and depending on their design – spring-locked or rigidly – in tension or compression direction. The locking function is made possible by a valve that is integrated into the piston; the valve separates the two pressure chambers in a gas leak-proof manner. If it is closed and the gas exchange between the two pressure chambers is interrupted, the BLOC-O-LIFT® gas spring is locked. The valve closes automatically as soon as the valve tappet is released from the outside.

Properties and Advantages

- Available with rigid locking in tension and compression direction. Optionally, this function can be achieved regardless of the orientation.
- Also available with a small actuation range of 1 mm (standard 2.5 mm) for very easy operation.
- Upon request, these safety applications are available with an override function.

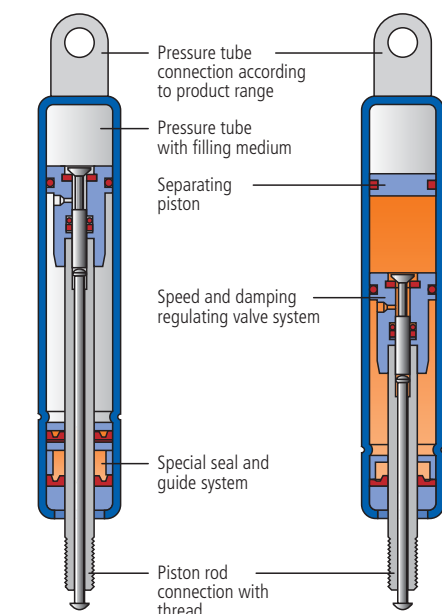

Left: BLOC-O-LIFT® gas spring with spring locking

Right: BLOC-O-LIFT® gas spring with rigid locking and separating piston for orientation-independent installation

Gas Springs and Dampers in the Automobile

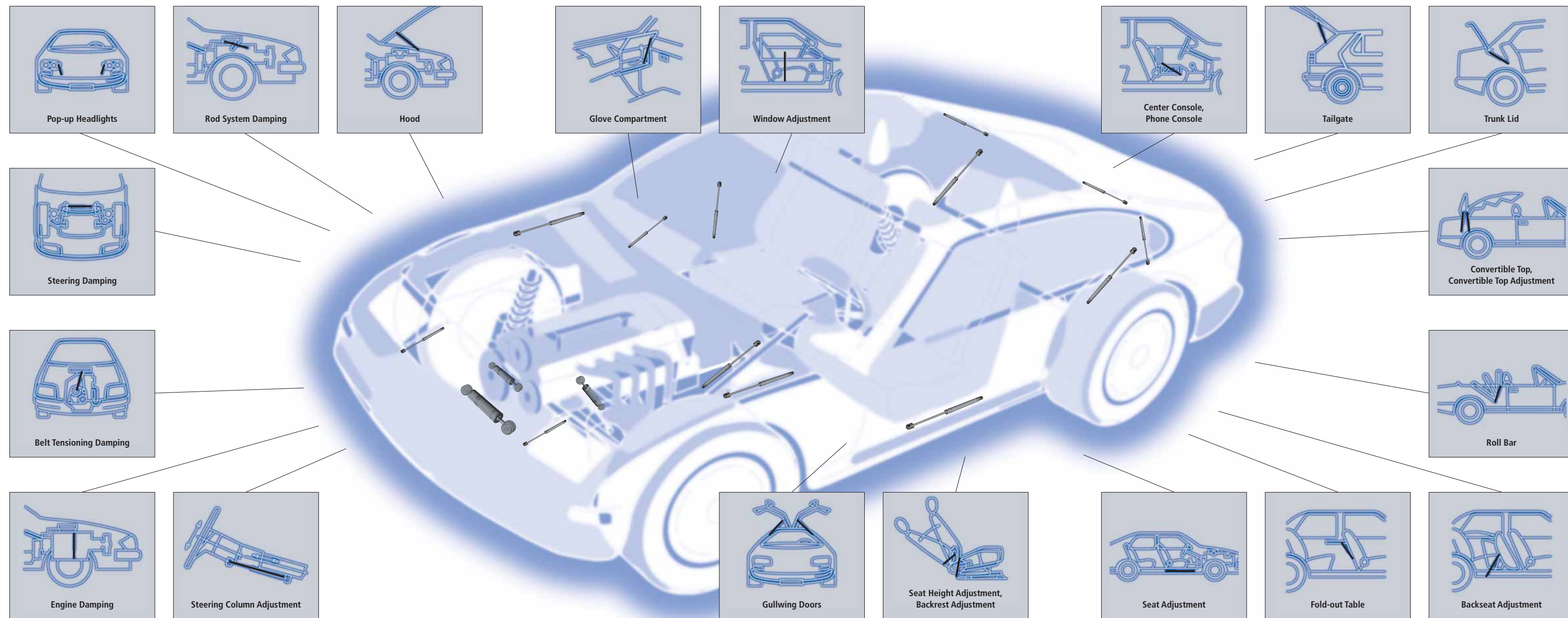

Gas Springs and Dampers for Utility Vehicles

Compact design, high functional comfort and integrated operating safety expand the range of applications for STABILUS products in utility vehicle design.

e.g., vehicle bodies...

Gas springs and dampers make it easy to open and adjust tailgates, hoods, and covers.

e.g., trucks...

Gas springs are used for comfortable opening and securing of engine compartment covers, truck cab doors and windows. In the driver seat, they dampen unpleasant jolts due to bumpy roads and thus ensure a pleasant, relaxed, and ergonomic seating experience.

e.g., buses...

In luggage compartments, gas springs ensure comfortable opening, as well as dampened, safe, and noiseless closing. Because the seats can be adjusted ergonomically, even long journeys are a pleasant experience.

Other Applications:

- Shelf for the driver
- Shelf for carry-on bags
- Glove compartment
- Battery compartment
- Folding roof
- Tailgate

- Front end lid
- Steering
- Cover tarp
- Hood
- Air deflector
- Bunk

- Motor
- Carburetor control
- Manual transmission
- Driver seat
- Driver's cab
- Luggage compartment

- Maintenance compartment
- Seats
- Roof light
- Steering column
- Radio cover



STABILUS – A company with an innovative tradition

Pioneer Performance

In 1962, STABILUS presented the world's first gas spring manufactured in series production to the swivel chair industry; in 1965, the first lockable gas spring. To date, more than 2.0 billion gas springs have been produced, giving STABILUS the longest experience world-wide in the design and manufacture of gas springs. With an annual production of more than 100 million units, STABILUS is today the world market leader for multiple industrial applications. Occupational health practitioners and swivel chair manufacturers appropriately consider STABILUS a pioneer in the development and manufacture of gas springs for ergonomic seating in the swivel chair area. The gas spring makes it possible to adjust height, seat and backrest tilt of the swivel chair quickly and easily.

Globally Active

With a global sales and service network and 10 production sites in Europe, USA, Mexico, Brazil, New Zealand, Australia and Korea STABILUS supplies and supports more than 2,400 customers world-wide.

For all business sectors

Having been successfully adopted and incorporated in the automotive and furniture industries for several decades, STABILUS gas springs have now also become an indispensable design element in countless industrial applications in the most diverse sectors.



Gas springs and dampers for applications in vehicle engineering

Compact design, high level of operating convenience and safety in use continue to expand the field of applications for STABILUS products.

e.g. Motor vehicles and superstructures ...

Gas springs and dampers facilitate the opening and adjustment of hoods, hatches and covers.

e.g. Agricultural vehicles ...

They dampen unpleasant shocks in the driver's seat caused by uneven land resulting in comfortable, relaxed and ergonomic seating.

e.g. Buses ...

They allow seats to be adjusted to the passengers' bodies, so that even long journeys become a positive experience.

e.g. Railway vehicles ...

Here, too, blocking gas springs in stepless adjustable seats ensure ergonomic seating.

Customer satisfaction

Customer service and customer satisfaction are key objectives for the company. STABILUS is known in particular for its technical innovation, quality and competitive pricing in all its business units.



Highest Quality

As the leading gas spring supplier worldwide, our quality management system fulfils without question the high quality requirements of international standards, such as DIN EN ISO 9001-2000, as well as the new world standard ISO/TS 16949-2002 with the regulatory requirements of QS 9000, VDA 6.1, EAQF, and AVSQ.

Care for the environment

STABILUS places utmost importance in achieving environmentally friendly production methods. Its success in this area is documented by the certification of its environmental management system in conformity with DIN EN ISO 14001.

Service and technical application support

STABILUS provides extensive technical, design and installation support in specific applications as a matter of course. The extensive know-how of our application consultants and technicians coupled with our highly efficient installation proposal programmes and practical arrangements, also on site, ensure optimal solutions.

Product characteristics, advantages, uses

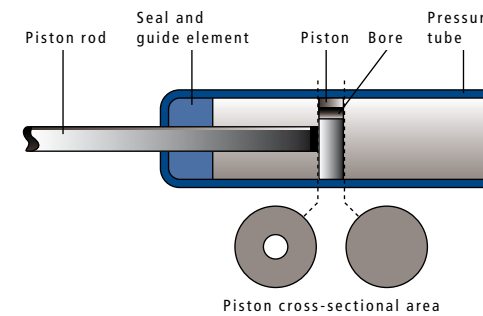

Operating principle

Operating principle of a gas spring

The gas spring is a hydropneumatic adjusting element, consisting of a pressure tube, a piston rod with piston and appropriate connection fittings. It is filled with compressed nitrogen, which acts with equal pressure on differently dimensioned cross-sectional areas of the piston. This produces a force in the extension direction. This extension force can be exactly defined within physical limits through the appropriate selection of the filling pressure.

Spring characteristic curve and F1 force

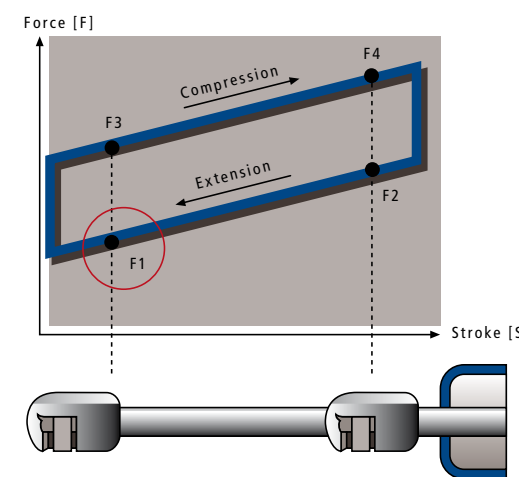

Spring characteristic curve and F1-force

The spring characteristic curve describes the gas spring progression force over the stroke, i.e. from the extended to the compressed state and vice versa.

Unlike mechanical springs, gas springs have an extremely flat, almost linear characteristic curve and therefore allow a uniform comfortable adjustment or pivoting movement. The spring rate, X , representing the force ratio $F2/F1$, lies between 1.2 and 1.4 with standard gas springs. Other values can be defined on request and according to the application. Together with the dimensions, the $F1$ force is the major descriptive feature for the choice of a gas spring and it is therefore specified in all STABILUS brochures. It defines the value of the spring force and is measured 5mm before the end of the extension movement. The difference between the force lines for the compression and extension direction, FR , is the result of friction effects.

Extending speed and damping

A significant advantage of gas springs over mechanical springs is the definable speedcurve, which allows for a damped and comfortable adjusting movement. Two types of damping can be distinguished:

Hydraulic damping

The extending speed is determined both by the arrangement and the diameter of the bores in the piston and by the viscosity of the oil used. When the gas spring is installed with the piston rod facing down the extending piston first travels through the gas-filled and then

through the oil-filled part of the pressure tube. As soon as it is immersed in the oil the piston rod moves at a considerably lower speed.

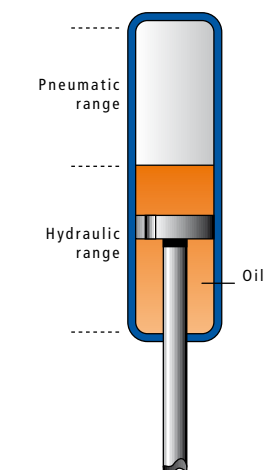
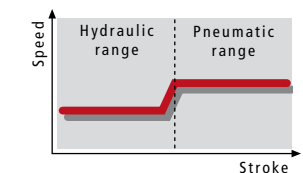

Hydraulic damping

Dynamic damping

Here the bore in the piston is replaced with a longitudinal groove in the wall of the pressure tube which serves as a bypass. Its geometry and the length determine the damping curve. This technique allows position-independent damping of the gas springs.

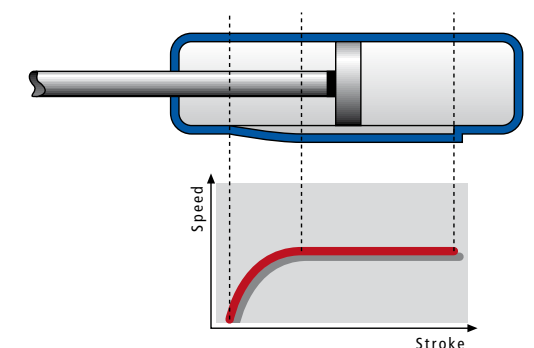

Dynamic damping

Choice and application of gas springs

Dimensions according to choice

STABILUS offers an extremely wide range of gas spring types, which vary in respect of their external dimensions, speed curves and extension variants, and invariably meet the most stringent requirements. A large selection is included in the STABILUS standard product range and can be delivered at short notice.

Service life and maintenance

Gas springs are maintenance-free! They are designed to specific requirements and operate for years and years without failure when properly installed. Also for particularly high numbers of load alterations special sealing systems are available which allow e.g. specific gas springs in swivel chairs to withstand up to one million load cycles without damage.

Connections

Different connections are available depending on the application. STABILUS therefore offers a wide range of plastic or metal hinge eyes, including the easy-to-mount angle joint that only has to be fitted on the ball socket and allows for twist-free installation.



Small selection of available connections

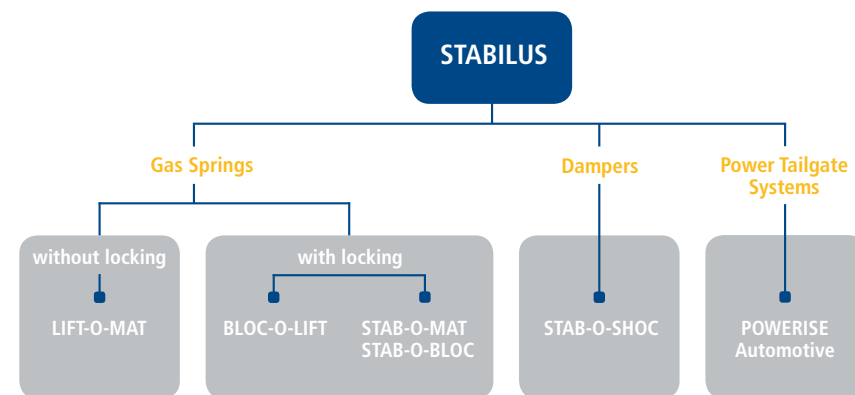

Installation instructions

Twist-free connection

For maximum service life, gas springs should not be exposed to twists or lateral forces. Suitable connection fittings, e.g. angle joints, can be used for the twist-free connection of the gas springs.

Installation position

Gas springs – except those designed for position-independent installation – are preferably installed with the piston rod facing down so as to maximise the hydraulic damping effect and to ensure optimal lubrication of the guide and seal system.

Temperature behaviour

The temperature of the gaseous nitrogen inside the gas spring influences its extension behaviour within certain limits. The standard temperature range lies between -30°C und +80°C. In addition, gas springs with special sealing systems for extreme loads are available.

Operational safety

The operational safety of the gas spring is primarily achieved by seals designed to keep the gas pressure inside. For your protection, no bending loads should be exerted on the gas springs. Damage caused by subsequent mechanical operations, including welding, performed on the gas springs, as well as contamination or painting of the piston rod may lead to the failure of the devices.

Non-blocking gas springs – LIFT-O-MAT®



Lifting, lowering, moving and adjusting

With their accurately adjusted extension force and application-specific damping LIFT-O-MAT® gas springs offer optimum weight compensation, force support, they open and close flaps and bonnets and ensure user-friendly movement sequences thanks to their damping characteristic.

Characteristics and benefits

- ▶ Available in a variety of standard sizes and force variants
- ▶ Linear spring curve for uniform force progression over the entire spring travel
- ▶ Available with progressive or degressive spring curve for force support at stroke start or end position
- ▶ Available with dynamic or hydraulic damping according to application and fitting position
- ▶ Various connection systems for practical and swift installation

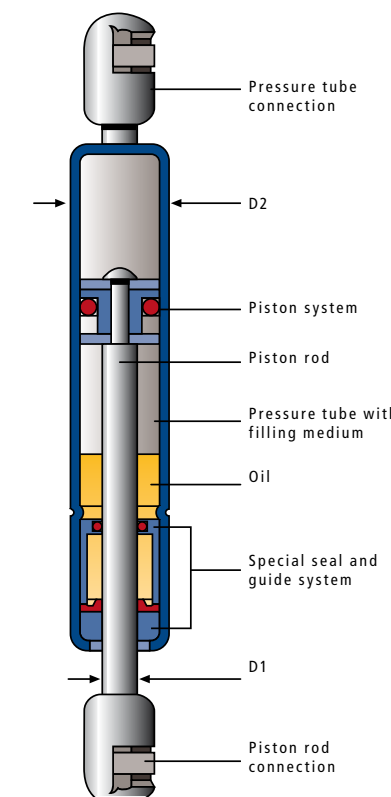

Product variants

- ▶ **Hydro-Lift®:** In addition to the LIFT-O-MAT® function, these gas springs can be positioned at any desired point
- ▶ **LIFT-O-MAT® high friction:** The increased friction of these gas springs allows for stepless positioning
- ▶ **Electro-Lift:** In addition to the gas spring function, an electric current is transmitted or even switched, e.g. for illuminating the engine compartment or bootspace
- ▶ **Inter-Stop®:** The stroke is divided into a number of functional areas to allow manual positioning of the application, e.g. a flap

Standard Series Program			
Piston rod diameter D1 (mm)	Pressure tube outside diameter D2 (mm)	Extension force (N)	Max. stroke (mm)
6	15	50 - 400	150
8	19	100 - 800	250
10	22	150 - 1150	400
14	28	500 - 2100	500
20	42	2400 - 5200	500

Blocking gas springs – BLOC-O-LIFT®



Variable positioning, rigid or spring blocking

BLOC-O-LIFT® gas springs raise loads with an accurately tuned extension force and application-specific dampening while ensuring user-friendly movement sequences. In addition, BLOC-O-LIFT® gas springs can be blocked in any position, with springing or rigid blocking in the extension or compression direction depending on the design. Variable blocking is made possible by integrating the valve into the piston, which separates both pressure chambers gastight. When the valve is closed, thereby interrupting the gas exchange between both pressure chambers, the BLOC-O-LIFT® gas spring is blocked. The valve closes automatically when the valve tap-pet is released externally. The springing blocking variant is ideal for the smooth dampening of e.g. shocks, impacts or pulse-type peak loads (e.g. in seats and office swivel chairs).

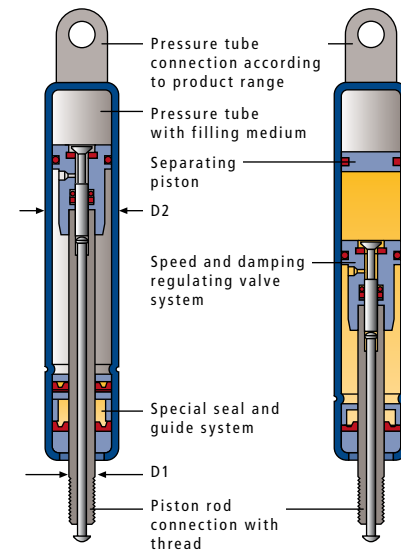

Left: Spring blocking BLOC-O-LIFT® gas spring

Right: Rigid blocking BLOC-O-LIFT® gas spring with separating piston for position-independent installation

Standard Series Program			
Piston rod diameter D1 (mm)	Pressure tube outside diameter D2 (mm)	Extension force (N)	Max. stroke (mm)
8	28	200 - 1000	100
10	28	200 - 1500	250



Characteristics and benefits

- ▶ Rigid or spring blocking in the extension or compression direction. Optionally, a position-independent variant is available
- ▶ Also available with short release travel of only 1 mm (normally 2.5 mm) for extremely light operation
- ▶ Continuous release is also available on request (e.g. for rocking the backrest of swivel chairs)

Dampers and STAB-O-SHOC®

Hydraulic dampening of vibrations

Dampers are needed to positively influence the nature of movements and vibrations. They are designed to match the particular application. Oil-hydraulic dampers consist of a pressure tube, a piston rod with piston system and a piston rod connection fitting. The movement of the piston presses the filling medium (oil) through suitably dimensioned bores into the piston, thus producing the desired damping force.

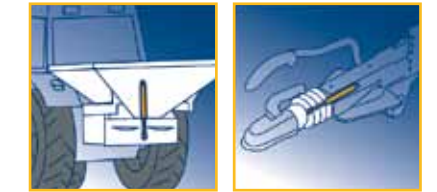

- ▶ Defined linear, progressive or degressive damping force characteristic for optimal results
- ▶ Variable damping rate e.g. for steering dampers and driver seat dampers
- ▶ Electrically adjustable dampers
- ▶ Several connection variants for easy installation

Characteristics and benefits

- ▶ Compact dimensions with maximum reliability and durability
- ▶ Suited for operating temperatures between -40°C and +130°C

Product variants

- ▶ Vibration dampening only at specific frequencies (frequency-dependent dampening) upon request

- ▶ Dampers are designed to optimally match the particular application
- ▶ For position-dependent or position-independent installation
- ▶ Dampers with or without extension force
- ▶ With damping forces in one direction or in the extension and compression direction

Instructions for the design of gas springs

Calculating the installation of a gas spring

The STABILUS installation design proposal software selects and designs the optimal gas spring for a specific application. For this, the following application details, e.g. a flap, are needed:

- ▶ dimensions and weight
- ▶ opening angle to be achieved
- ▶ attachment points for the gas springs

From this data the following is derived:

- ▶ the stroke A [mm]
- ▶ the extended length B [mm]
- ▶ the extension force F 1 [N]
- ▶ and the type of connection

In a subsequent step, the desired extension and damping characteristic can be determined.

To make your own rough estimate and to select the appropriate gas spring from our standard product range, you can use the following approximation formula and application sketch.

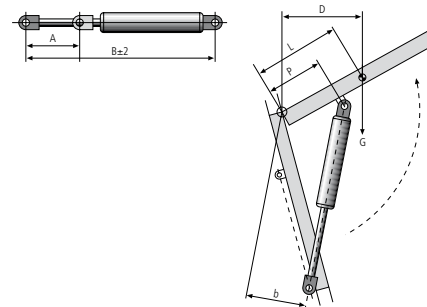

Determining the extension force F1 [N] at 20°C

$$F1 = \frac{G \times D}{b \times n} \times 13 \text{ [N]}$$

- G = weight of flap in kg
- L = distance from centre of gravity to pivot point in mm.
- b = effective lever arm of gas spring in mm, flap open.
- 13 = conversion factor kg-N + safety margin
- P = flap attachment (suggest approx. 2/3 L)
- n = number of gas springs (standard: n = 2)
- D = effective lever arm of gravity in mm, flap open