



INSTALLATION INSTRUCTIONS

51145

REAR ANTI-SWAY BAR

1992-1999 HONDA CIVIC REAR ANTI-SWAY BAR, 1993-1997 HONDA DEL SOL
1994-1999 ACURA INTEGRA

Congratulations! You were selective enough to choose a SUSPENSION TECHNIQUES PRODUCT. We have spent many hours developing our line of products so that you will receive maximum performance with minimum difficulty during installation.

Note: Confirm that all of the hardware listed in the parts list is in the kit. **Do not** begin installation if any part is missing. Read the instructions thoroughly before beginning this installation.

Warning: **DO NOT** work under a vehicle supported by only a jack. Place support stands securely under the vehicle in the manufacturer's specified locations unless otherwise instructed.

Warning: **DO NOT** drive vehicle until all work has been completed and checked. Torque all hardware to values specified.

Reminder: Proper use of safety equipment and eye/face/hand protection is absolutely necessary when using these tools to perform procedures!

Note: It is very helpful to have an assistant available during installation.

RECOMMENDED TOOLS:

- Properly rated floor jack, support stands, and wheel chocks
- Combination wrench set
- Ratcheting socket wrench and socket sets
- Safety Glasses

KIT INSTALLATION

1. Open the hardware kit and remove all of the contents. Refer to the part list (Page 3) to verify that all parts are present.
2. Park the vehicle on a smooth, level concrete or seasoned asphalt surface and activate the parking brake. Block the FRONT wheels of the vehicle with appropriate wheel chocks; making sure the vehicle's transmission is in 1st gear (manual) or "Park" (automatic).
3. Using a properly rated floor jack, lift the REAR wheels of the vehicle off the ground. Place support stands, rated for the vehicle's weight, and in the factory specified locations. Refer to the vehicle Owner's Manual. Prior to lowering the vehicle onto the stands, make sure the supports will securely contact the chassis.

! It is very important that the vehicle is properly supported during this installation to prevent personal injury and chassis damage! Make sure that the supports stands are properly placed prior to performing the following procedures. We **DO NOT RECOMMEND** using wheel ramps while performing this installation.

4. Slowly lower the vehicle onto the stands and, before placing the vehicle's entire weight on them, again check that they properly and securely contact the chassis as described above. Check for possible interference with any lines, wires, cables, or other easily damaged components.

5. Skip this step if your vehicle does not have an original equipment Anti-Sway Bar. Remove the end links from the ends of the original equipment Anti-Sway Bar. Remove the bushing brackets as well. Remove the original equipment Anti-Sway Bar and the brackets from the vehicle.
6. Thoroughly lubricate the **inside** of your new hyper thane bushings using a high-grade lithium or silicone-based grease with molybdenum disulfide (moly). Place the bushings on the new Anti-Sway Bar.
7. Remove the driver's side rear strut assembly and rotate it 180° so that the nut welded to the strut is on the rear side of the control arm. Re-install the strut. Do the same with the passenger side of the vehicle. **Do not** replace the lower bolt, but remove the inner lower control arm pivot bolt. Refer to the diagram for the location of this bolt.
8. Vehicles with original equipment Anti-Sway Bar go to step 7. For '96-'99 Civics go to step 6. Drill out the holes as shown in the diagram to 7/16" on both sides of the vehicle. Unbolt the ABS bracket attaching the wire to the frame at the inner pivot of the lower control arm, if equipped. Knock out the nut welded (see diagram) to the frame with a punch and hammer. Cut out the corner section of the ABS bracket (see diagram). Drill the bottom hole to 7/16". Ream the bottom hole to the outside of the vehicle (refer to the diagram). You must be able to mount the bushing brackets approximately 90 degrees to the ground. Go on to step 7.
9. **This step is for '96 and newer vehicles only.** Place the flat plate up against the cross member and scribe the holes with a marker onto the frame. Make sure the holes are 90° to ground (see diagram). Drill the holes you just marked to 7/16". Do this to both sides of the vehicle. (It may be easier to access the mounting hardware if the control arms are dropped out of the cross member prior to installation.)
10. **IMPORTANT NOTE:** The rear suspension of the vehicle **must be** compressed (at ride height) to allow the Sway Bar ends to clear the brake line brackets. If the suspension is at full droop, the Bar will not line up properly and the end links are very difficult to install and align. If available, lower the rear of the car on to vehicle ramps to compress the suspension. Or, jack stands may be used to support the vehicle and compress the rear suspension to approximately the proper ride height location. If this procedure is used, place a second set of jack stands in the manufacturer's recommended location as a safety precaution.
11. Position the Anti-Sway Bar so the ends are facing forward above the control arms. Install the brackets on the bushings. Secure the pivot bushings, brackets, Anti-Sway Bar and the flat plate to the cross member as shown in the diagram using the 3/8" bolt and nylock nut. '92-'95 models use a spacer tube under the flat plate. Make sure you use a washer next to the head of the bolt and next to the nylock nut. Refer to the diagram.
12. Check that all components and fasteners have been properly installed, tightened and torqued.
13. Check brake hoses, steering and other components for any possible interference.
14. Lift vehicle and remove support stands. Carefully lower vehicle to ground.
15. Immediately test-drive the vehicle in a remote location so that you can become accustomed to the revised driving characteristics and handling. Be aware that the vehicle will handle substantially different now that it has been modified.
16. Installation is complete. Check all of the hardware and re-torque at intervals for the first 10, 100, 1000 miles.

PARTS LIST FOR ANTI-SWAY BAR KIT 51145

**1992-1999 HONDA CIVIC REAR ANTI-SWAYBAR, 1999-1997 HONDA DEL SOL
1994-1999 ACURA INTEGRA REAR ANTI-SWAYBAR**

PART No.	DESCRIPTION	QTY.
51145-300	3/4" ANTI SWAY BAR	1
113195	3/4" PIVOT BUSHINGS	2
113000	GROMMETS	8
114020	BUSHING BRACKET	2
114042	FLAT PLATE	2
114034	ENDLINK ANGLE BRACKET	2
112134	3/8"-16 X 6" HEX HEAD CAP SCREW	2
112518	3/8" USS FLAT WASHER	8
112094	3/8"-16 X 1.25" HEX HEAD CAP SCREW5	4
112100	3/8"-16 X 1.75" HEX HEAD CAP SCREW5	2
112502	CUPPED WASHER Large	8
110255	3/8"-16 NYLOCK NUT	8
112450	SHORT SPACER TUBE	2
112416	SPACER TUBE	2
112008	8mm - 1.25 x 30mm HEX HEAD CAP SCREW5	2
110204	5/16" SAE WASHERS	2
55000-10	GREASE PACK	1

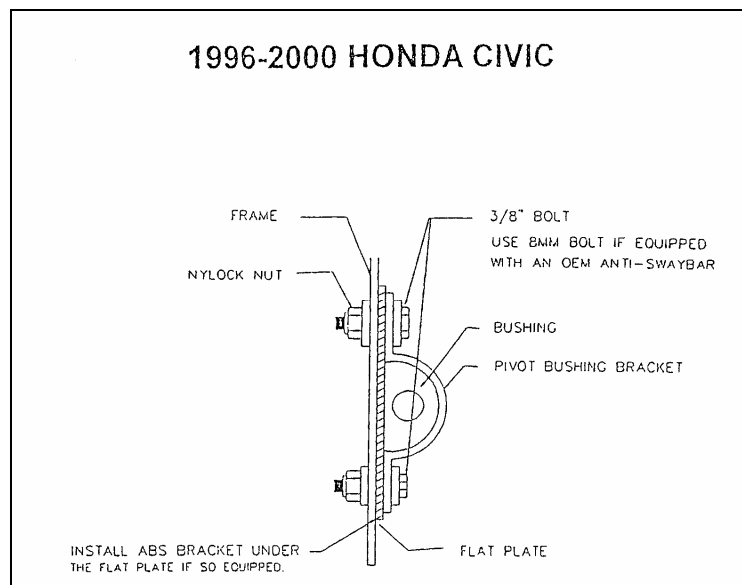

USE THE FLAT PLATE AS
A TEMPLATE AND DRILL OUT
MAKE SURE NOT TO PENETRATE
THE ARM.

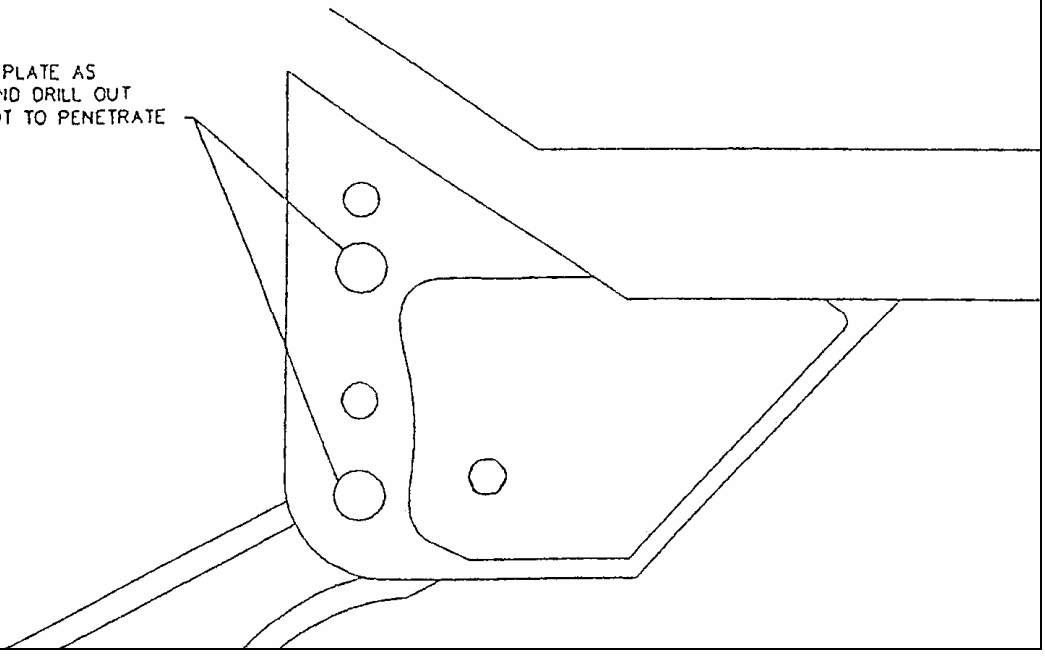

1992-1995 HONDA CIVIC
 1993-1997 HONDA DEL SOL
 1994-1999 ACURA INTEGRA

FRONT OF VEHICLE

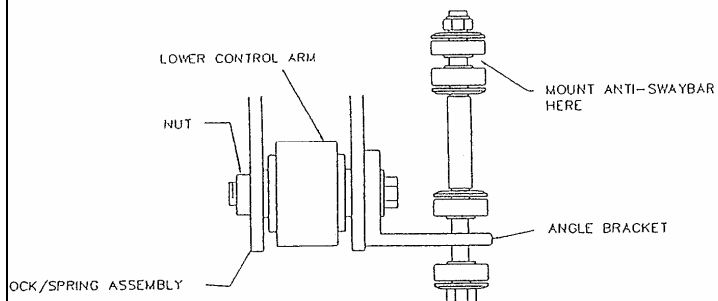

SIDE VIEW LOOKING OUTWARD FROM CENTER OF VEHICLE

TRIM BRACKET ON DOTTED LINE

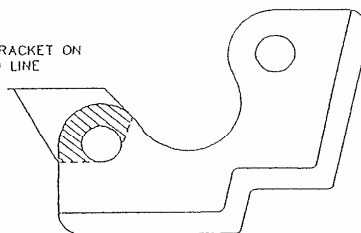

ABS BRACKET

O.E.M. ANTI-SWAYBAR BRACKET MOUNT LOCATION USE 8MM BOLT IF EQUIPPED WITH AN OEM ANTI-SWAYBAR

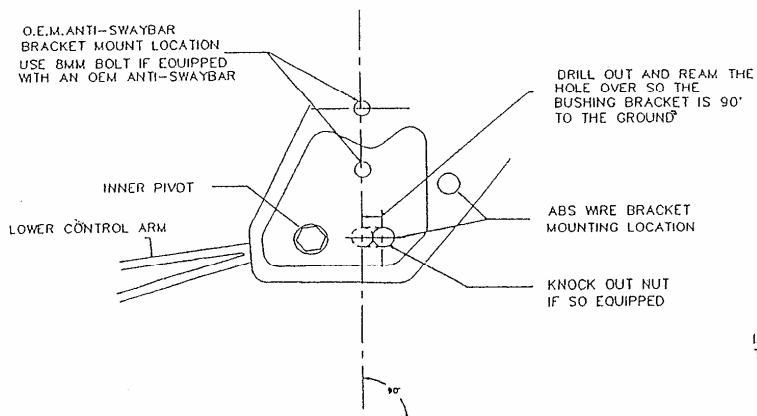

DRILL OUT AND REAM THE HOLE OVER SO THE BUSHING BRACKET IS 90° TO THE GROUND

