 Hitch must have a minimum Class II rating.

MAX
45 Lb
20 Kg
1 BIKE



MAX
90 Lb
40 Kg
2 BIKES



MAX
132 Lb
60 Kg
3 BIKES



MAX
180 Lb
80 Kg
4 BIKES



PARTS INCLUDED

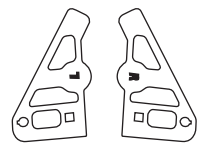
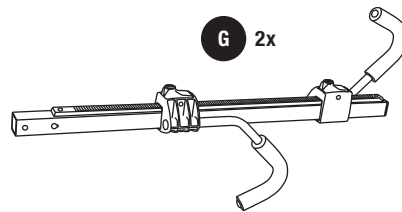
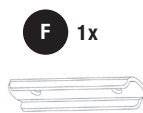
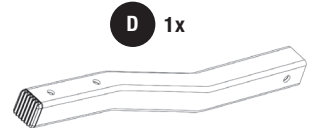
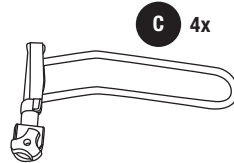
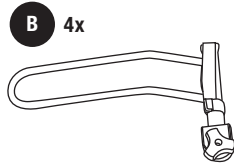
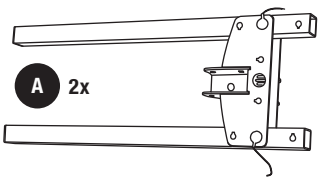

WARNINGS / LIMITATIONS

- 4 Bike maximum carrying capacity = 180 lbs./80Kg
- Fits 20-29" wheels up to 3" wide.
- Can work with bikes with fenders.
- Check tightness off all bolts periodically.
- Check straps for wear and replace periodically.
- Not intended for off-road use.
- Not intended for tandems or recumbents.
- Do not install on trailer or towed vehicle.

1



Tighten Well

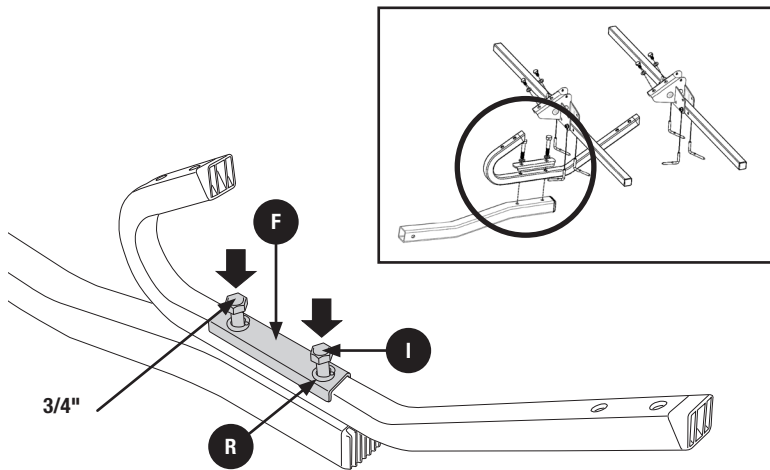

IMPORTANT

Do not over tighten.

Do not use power or pneumatic tools.

2

2 X

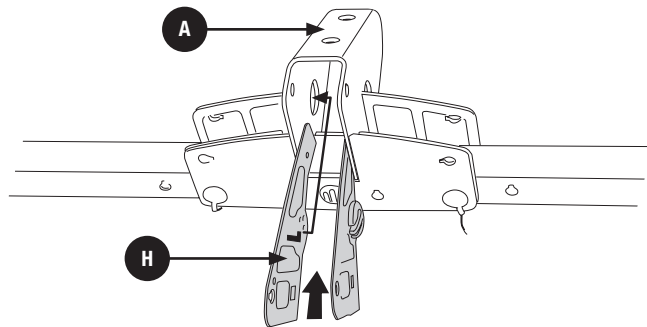
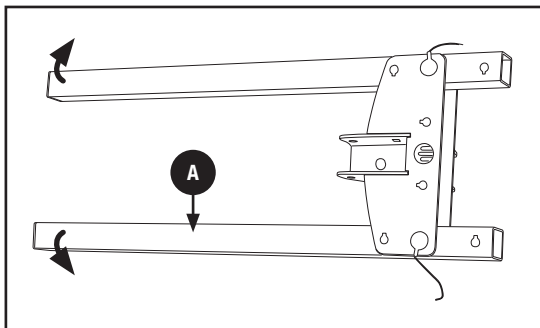

3

2 X

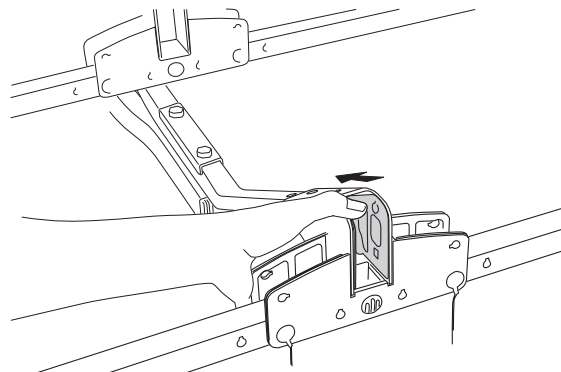
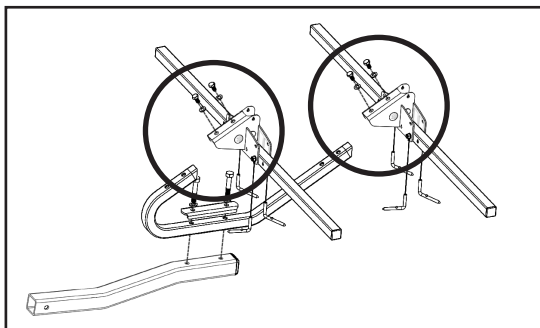

4

2 X

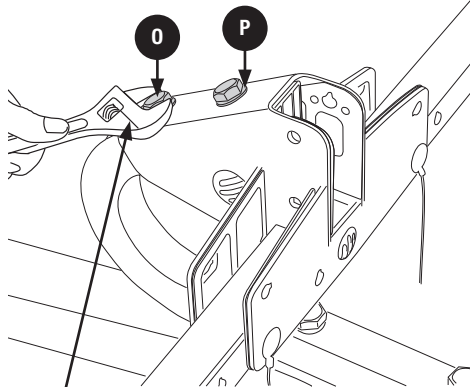

17 mm
(not included)



Tighten Well

5

2 X

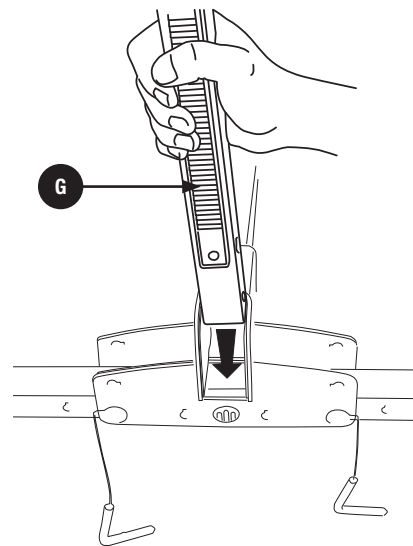

6

2 X

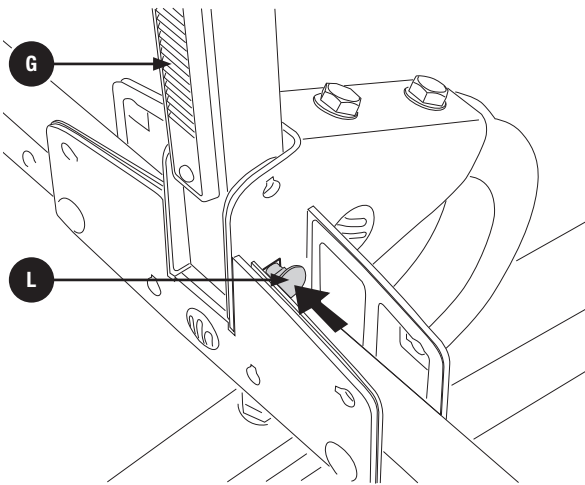

7

2 X

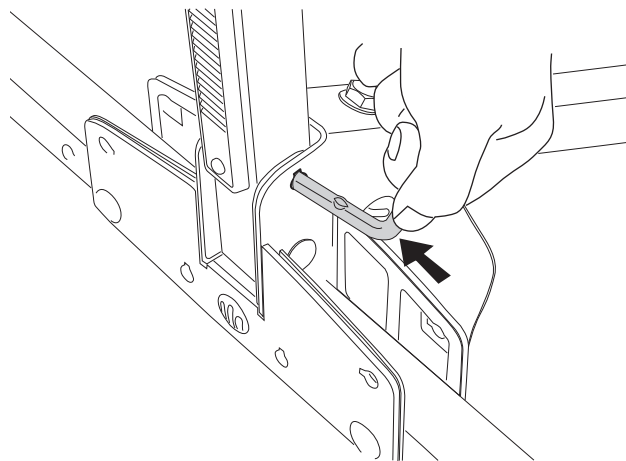

8

2 X

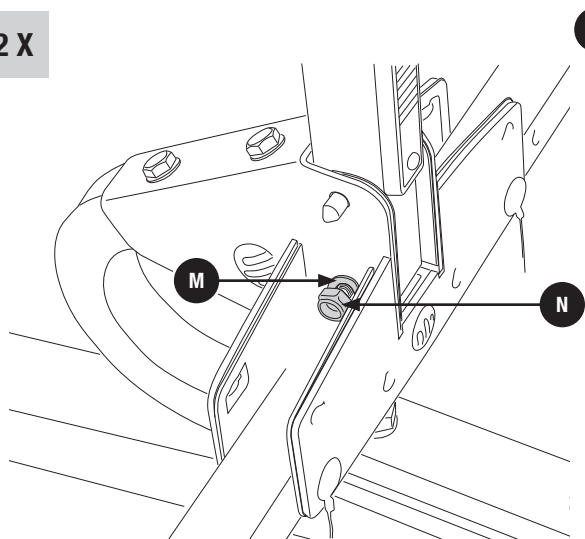

B



Tighten Well

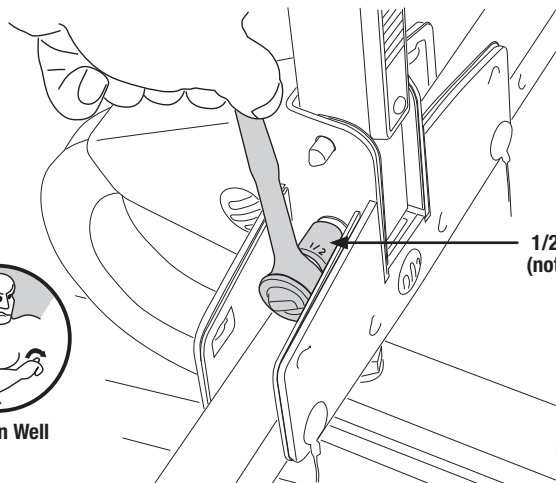

1/2" / 13mm
(not included)

9

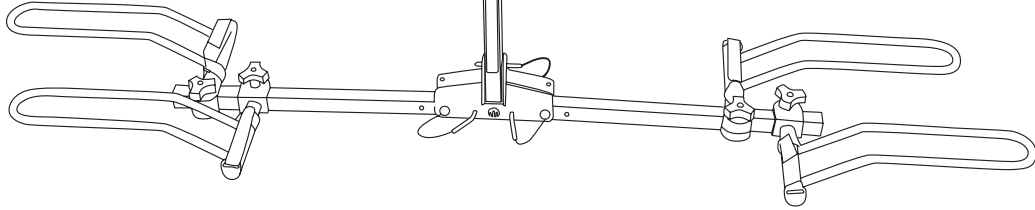
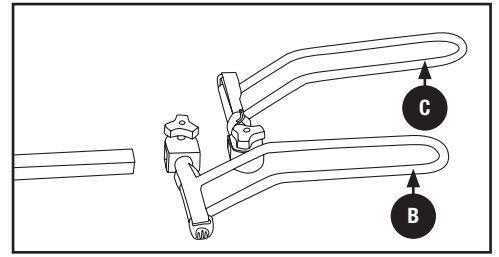
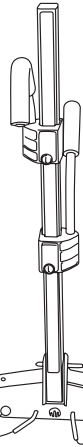
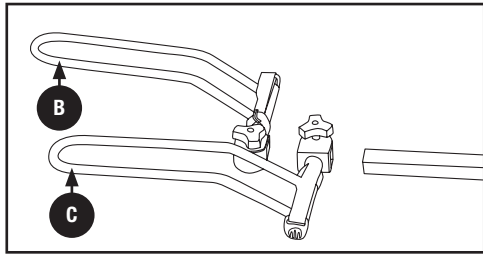

10

FOOT INSTALLATION FOR 2" RECEIVERS

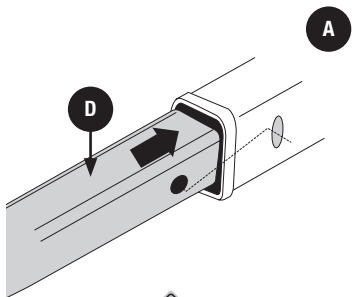

Receiver Installation

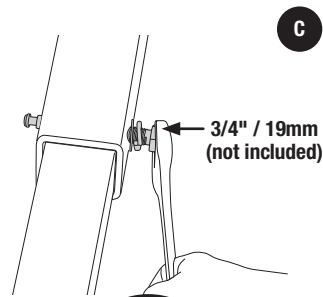
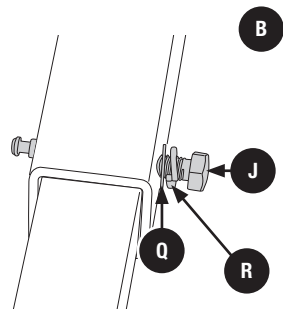

Tighten Well

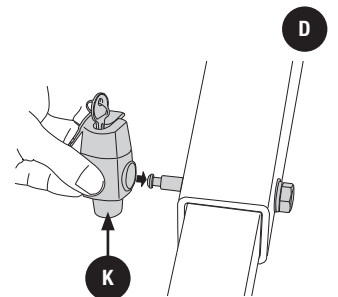

Lock should click onto the end of the bolt.

11

THE RACK IS NOW READY TO LOAD BIKES.

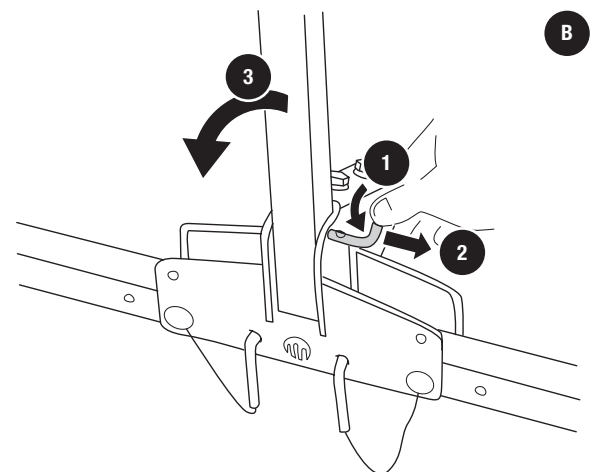
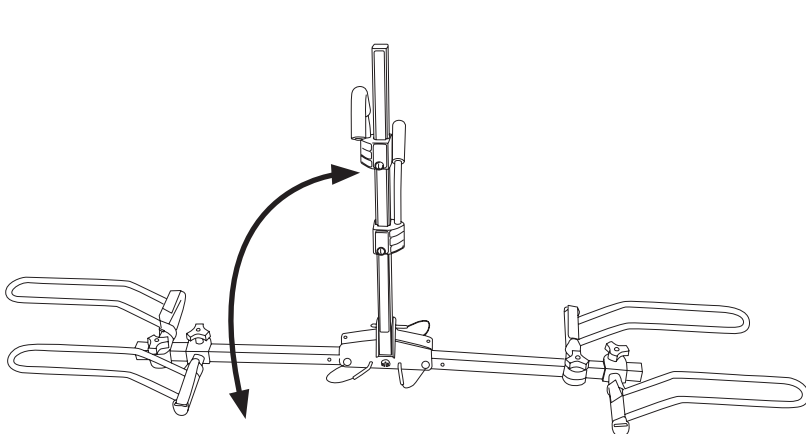

12

A

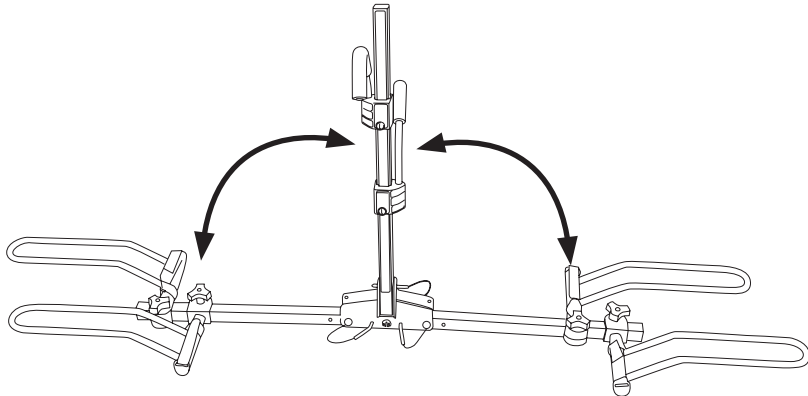

B

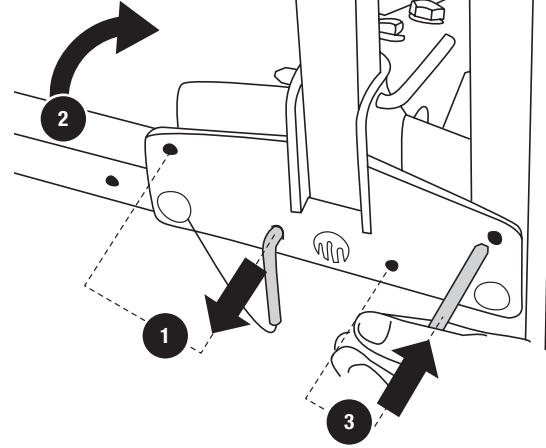

13



Bicycle Installation

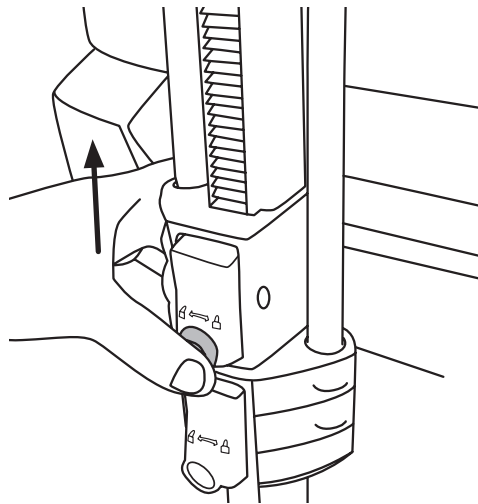

Raise the hooks by depressing the grey buttons and sliding the hooks upward on the mast.

14

A

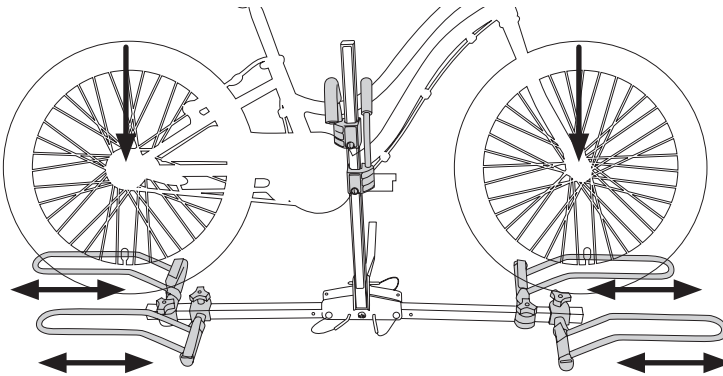

Place the bike on the bike tray with the wheels in the wheel trays and push down hook firmly until top tube fits snug against top bend of hook underside. If loading two bikes, load the first bike (heaviest bike) onto the tray closest to the vehicle.

B

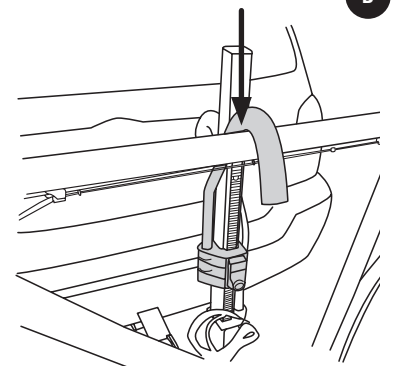

Push down hook firmly

15

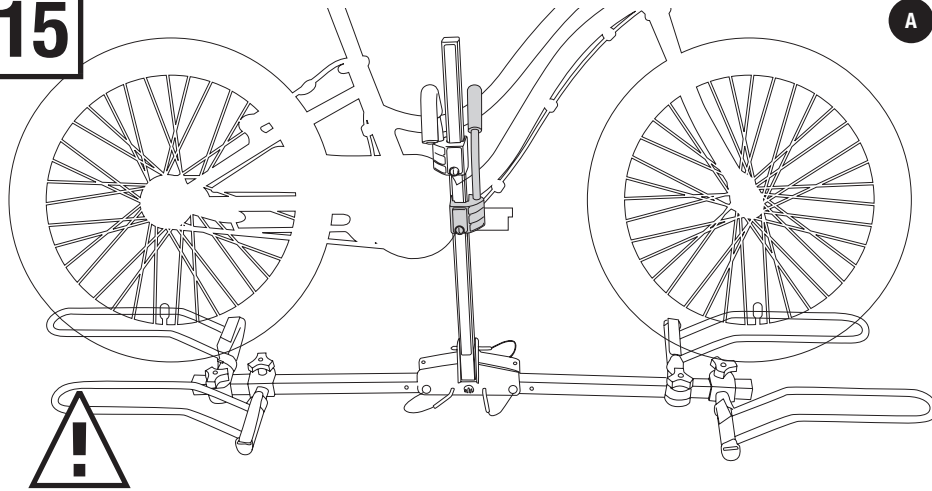

ALWAYS POSITION SMALLER BICYCLE BETWEEN THE BICYCLE SUPPORT AND THE CAR BUMPER. THE BUYER SHOULD BE AWARE THAT THE COMBINED WEIGHT OF THE BICYCLE CARRIER (69 lbs/31 kg) AND BICYCLES COULD EXCEED THE MAXIMUM WEIGHT ALLOWED FOR A TRAILER OR A FIFTH-WHEEL. NOT RESPECTING THE PERMISSIBLE MAXIMUM LOAD AUTOMATICALLY VOIDS WARRANTY.

B



Tighten Well

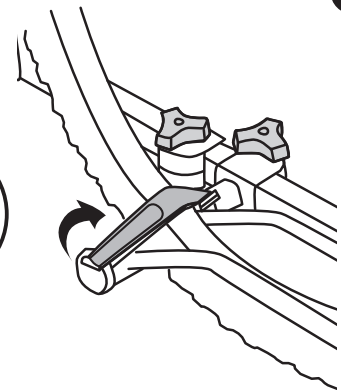

Attach wheel straps to front and rear wheels as shown. Check security of bike. Tighten down hook or wheel straps if needed.

16

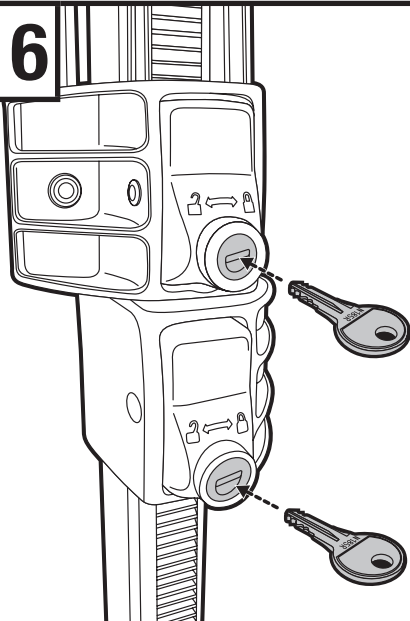

A

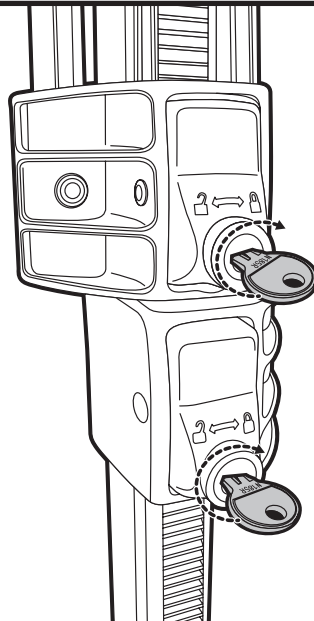

B

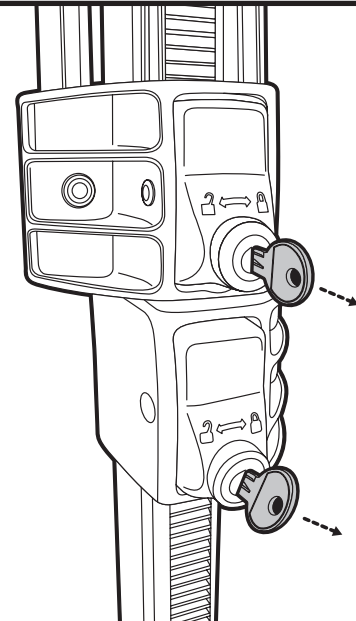

C

To lock the bikes to the carrier.