

# Rear Camber Arms Kit Installation Instructions SPL RLL Z34

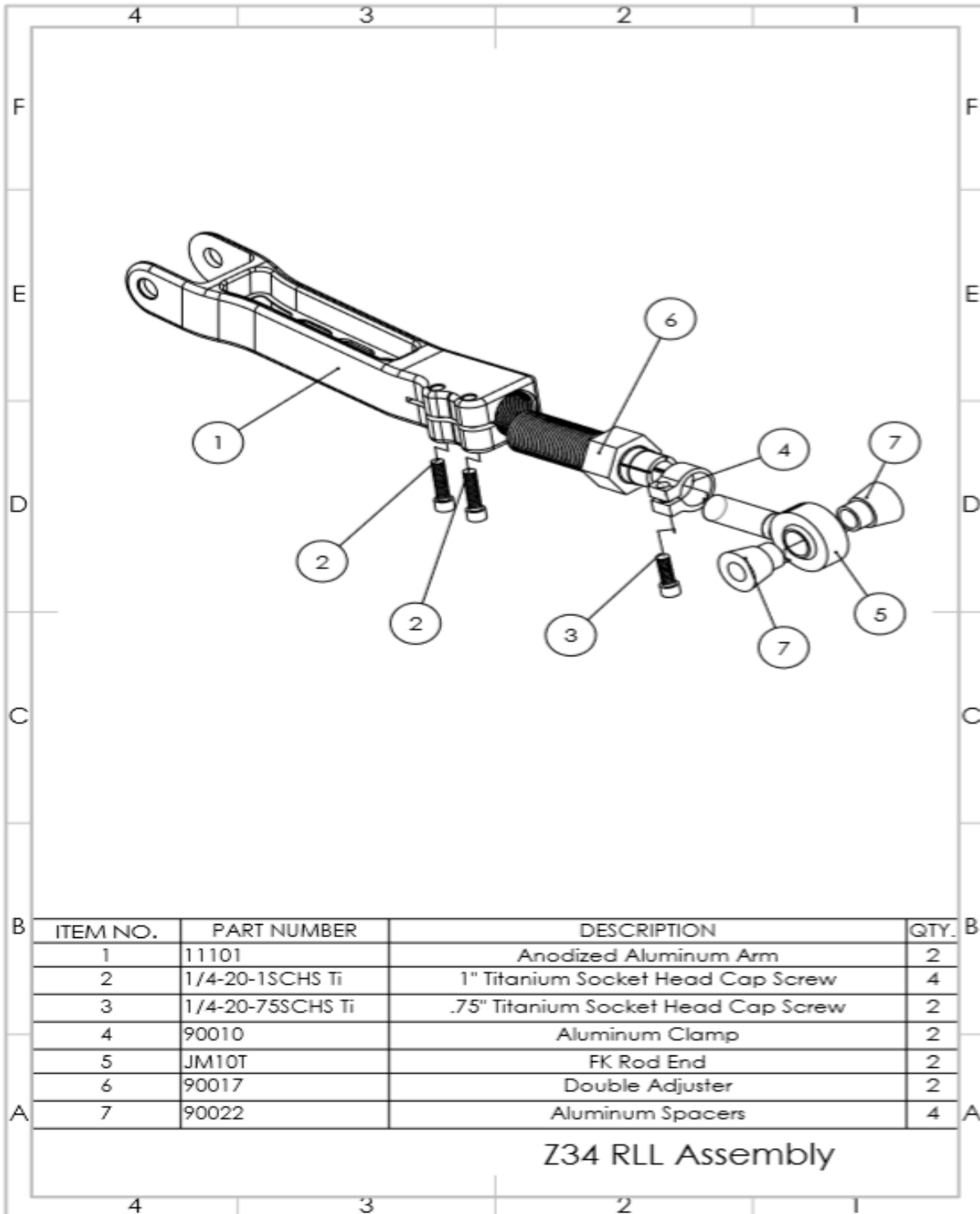

SEC. 430-431

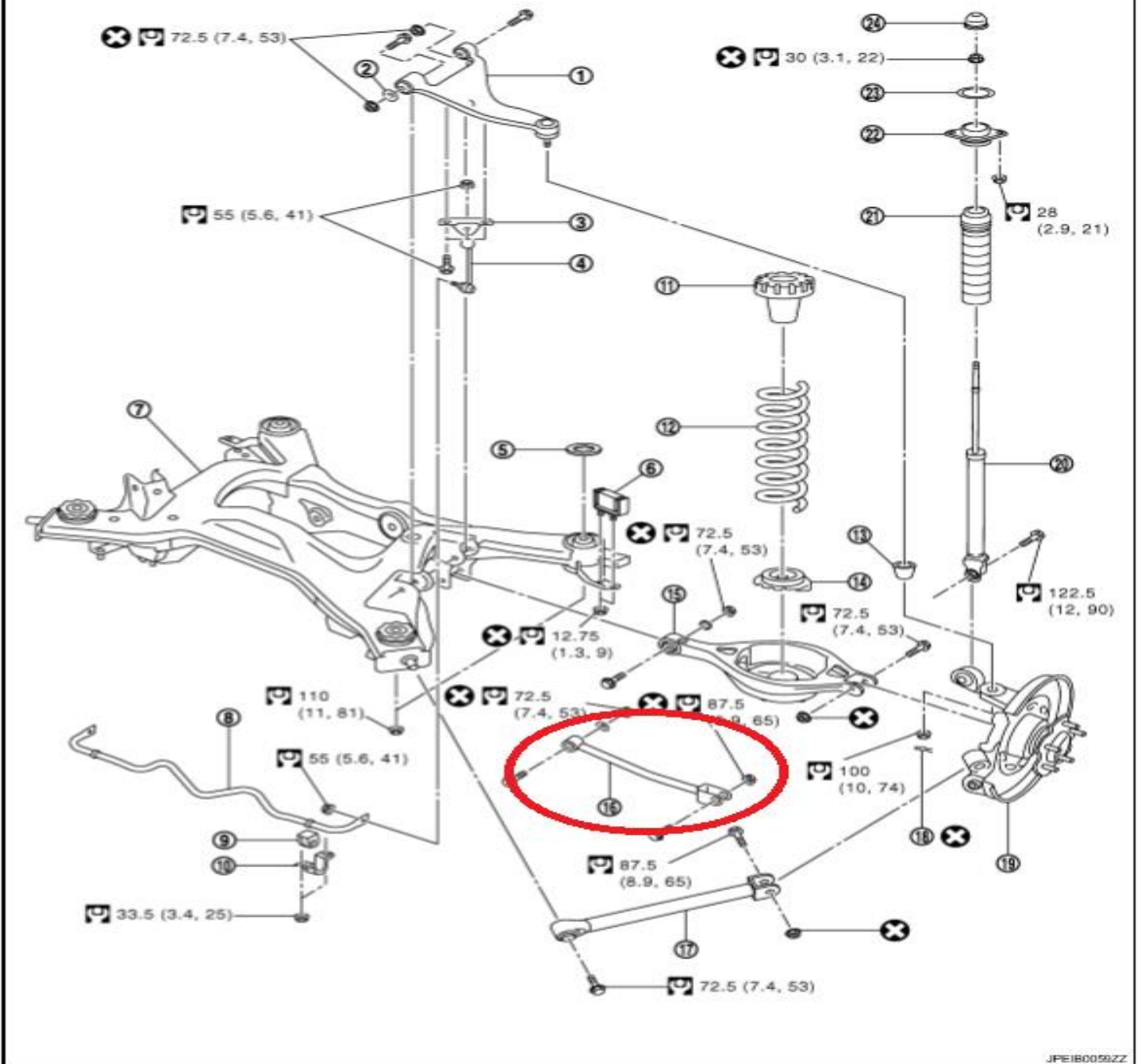

Thank you for your purchase of this SPL performance suspension product. Please follow these instructions exactly to ensure that the product is able to function to the best of its

ability, and you can achieve the most performance out of your vehicle.

1. Apply the parking brake and shift your vehicle in park for an automatic transmission or 1st gear for a manual transmission.
2. Jack up the rear of your vehicle so that the rear tires are no longer touching the ground. Place jack stands in factory recommended locations to safeguard both the vehicle and yourself from harm.
3. Remove the rear wheels off of the vehicle and place them to the side.
4. Remove the stock rear lower camber arm from the subframe and knuckle of the vehicle. The arm is pictured in the above blow up view of the suspension.
5. Take the SPL RLL and hold it next to the stock arm you just removed. Adjust the FK rod End (5) and Double Adjuster (6) to line up the bolt holes so that the stock arm and the SPL RLL are the same length. This will make it easier to align the vehicle after installation. Once the arms are the same length, tighten all Titanium Socket Head Cap Screws (2,3) to 150 **in-lb** maximum. This is generally accomplished with a normal 3/16" allen key, but make sure that the allen key is fully seated. The goal is to make sure the linkage cannot be rotated without excessive force.
6. Install the subframe end of the SPL RLL first. This is the end with the FK Rod End (6) and Aluminum Spacer (7). Make sure that the FK Rod End is in the middle of its articulation when installing it into the subframe. This will ensure that the arm has the ability to move through its suspension travel without binding, and that the FK Rod End will not wear prematurely.
7. Place the clevis end of the arm over the knuckle, and slide the bolt through.
8. Tighten the bolt at the subframe to 53 **ft.-lb.** and the bolt at the knuckle to 65 **ft.-lb.**
9. Repeat the process on the other side of the vehicle.
10. Place the wheels back on the car. Jack up the car and remove the jack stands, then slowly lower the vehicle back down onto the ground.

11. Take your car to a professional alignment shop. Make sure to bring these instructions to confirm that the arm is adjusted correctly.

12. Be safe, and enjoy your new SPL performance suspension upgrade!

## Adjustment

To adjust the alignment of the vehicle, first loosen all of the Titanium Socket Head Cap Screws. Place a wrench around the hex on the Double Adjuster. Turn counterclockwise to shorten the arm, and turn clockwise to lengthen the arm. Once the arm is the desired length, tighten all Titanium Socket Head Cap Screws to 150 **in.-lb.** Always ensure that the FK Rod End is in the middle of its articulation while at ride height.

## SPL Double Adjuster

The hybrid adjuster is what is known as a **double adjuster**. On the outside, the thread is left-handed. On the inside, the thread is right-handed. When the suspension arm is installed, turning the hybrid adjuster will allow you to lengthen/shorten the assembly. When lengthening/shortening, be sure to keep the arm and rod end from freely rotating when you turn the adjuster. Do not make the following mistakes (threading out **only** the adjuster or threading out **only** the rod end):



*Overextended adjuster.*

*Overextended rod end.*

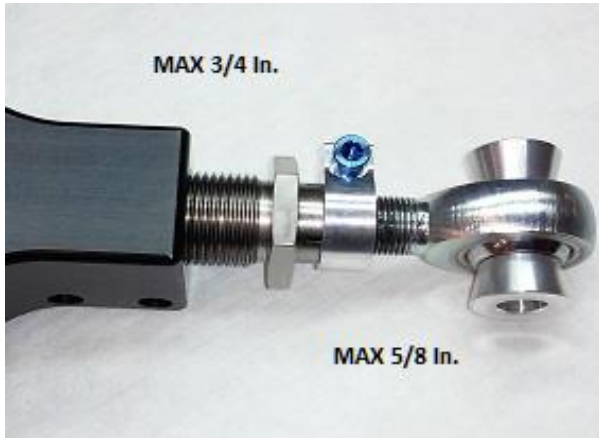

*Properly adjusted.*

This picture shows a properly threaded adjuster. The rod end (heim joint) will thread out about 2/3 the length of the adjuster. Note the maximum adjustment limits shown.

You'll notice in the pictures that the threads of the rod end and the adjuster have some dark material on them. That is anti-seize compound we apply to all of our

products so that adjustments should be easy and trouble free for quite some time.

The advantage of the hybrid adjuster is that you can easily keep the rod end bearing centered during and after alignment. Make sure to keep the bearing centered as shown.

