



Installation Instructions Stud Mounted Rocker Arms

6/29/2017

By Marketing Speedmaster

Introduction

Speedmaster Aluminum Stud-Mount Rockers can withstand valve spring loads up to 360lbs, the extruded body has a tensile strength of over 60,000 PSI.

Recommendations

Speedmaster recommends the following:

- Ensure that the supplied product is suitable for the intended application.
- Professional installation by a qualified technician.
- Inspect the relative engine components and mating surfaces for wear to ensure a trouble free operation.
- These rocker arms will increase valve lift over stock and will also affect piston to valve clearance, pushrod to head clearance, valve spring coil bind, and retainer to guide clearance. All of these clearances must be checked against manufacturers specifications after the installation of the rocker arms.
- Prior to installation, submerge the rocker arms in engine oil for a minimum period of one hour to ensure that the rocker arm assembly is well lubricated prior to engine start up.
- Replace all relevant engine components such as: pushrods, guide plates, etc. to ensure a trouble free operation and long service life.

Package Contents

- 16 x model specific Speedmaster DNA stud mounted rocker arms
- 16 x rocker arm posi-locks
- Pushrod length checking tool

Installation Instructions

- Remove the valve cover, rocker arms, pushrods, guide plates, rocker studs and roller lifters.
- Inspect all hardware for wear marks. Inspect the rocker stud threads, ensure they are free of any debris. It is good practice to chase the threads for proper fitment.
- Clean and blow dry all the pushrods and rocker arms. Ensure that parts are free of any debris.
- As recommended, submerge the pushrods and rocker arm assemblies in engine oil for an hour to ensure adequate lubrication prior to engine startup.
- Working on one cylinder at a time, place the guide plates on the cylinder head and align the rocker stud holes on the guide plate with the threaded mounting holes on the cylinder head.
- Install the rocker arm stud through the guide plate and into the cylinder head. Torque to OEM specifications.
- Apply engine assembly lube on the lifter end of the pushrod and in the lifter cup.
- Although unnecessary, it is good practice to apply a small amount of engine assembly lube on the pushrod guide area which may rub against the pushrod.
- Install the pushrod through the guide plate and into the lifter sockets. Spin the pushrod while gently pushing down against the lifter to ensure that the pushrod is in the center of the lifter.

- Repeat the process above for each pushrod.
- Apply engine assembly lube on tip of each pushrod prior to reinstalling the rocker arms.
- Lubricate all rocker arm studs with engine oil.
- Install rocker arm on rocker stud with the flat face of the rocker arm shaft facing up. Note the pushrod and rocker arm positioning, ensuring that the pushrod is seated in the center of the lifter and rocker arm seats.
- Install posi-locks loosely on the rocker arm studs with the set screws backed off. Do not tighten the posi-locks or set screws until the lifters are properly adjusted.
- Install the remainder of the rocker arms in this manner. (*TIP: Do not rotate the engine prior to installing the rocker arms, accidental bending of pushrods may occur.*)
- Once all pushrods and rocker arms have been installed on the cylinder head, set the valve lash or lifter preload.

For solid lifters, the valve lash must be set once the rocker arms have been installed. Valve lash is the clearance between the rocker arm tip and the stem of the valve. The process is slightly different for hydraulic roller lifters. This is because there is no clearance to set, rather the preload on the lifter is set to ensure that the plunger is in the center of its travel inside of the lifter assembly.

Most applications provide one of three valve lash or lifter preload adjustment methods. The method which is incorporated with stud mounted rocker arms involves a poly-lock mechanism. The poly-lock is fastened onto the rocker arm mounting stud to adjust the mounting height of the rocker arm on the stud which consequently sets the valve lash or lifter preload.

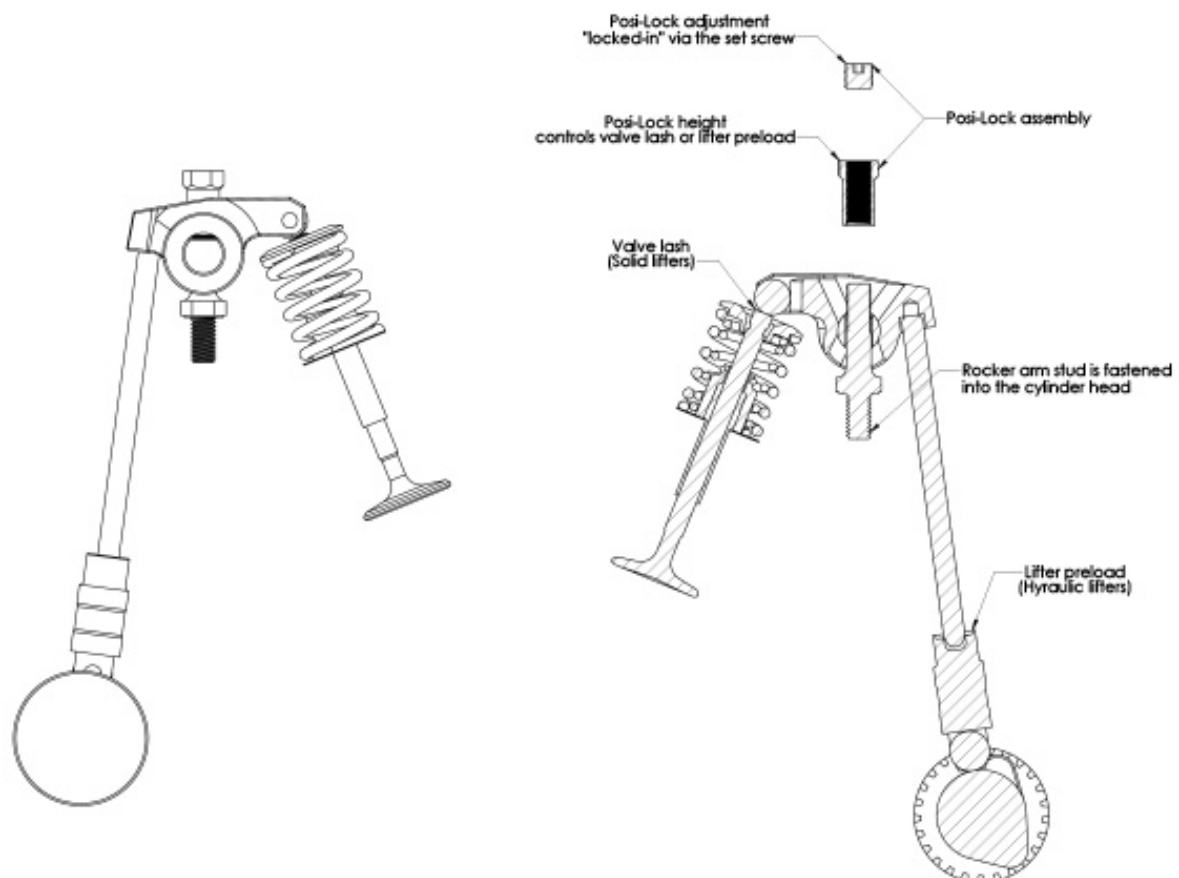

If the engine is complete and installed in the vehicle, run the engine until normal operating temperature is reached. This is referred to as “hot” adjustment. “Cold” adjustments should only be

used as a preliminary adjustment for new engines on an engine stand. The engine should be readjusted “hot” once the engine is assembled and run in the vehicle.

Common to both roller lifter types, hydraulic or solid, the roller must be on the base circle of the camshaft pre-adjustment initiation. The adjustment will be incorrect if the position of the lifter is not on the heel of the camshaft as shown in the figure

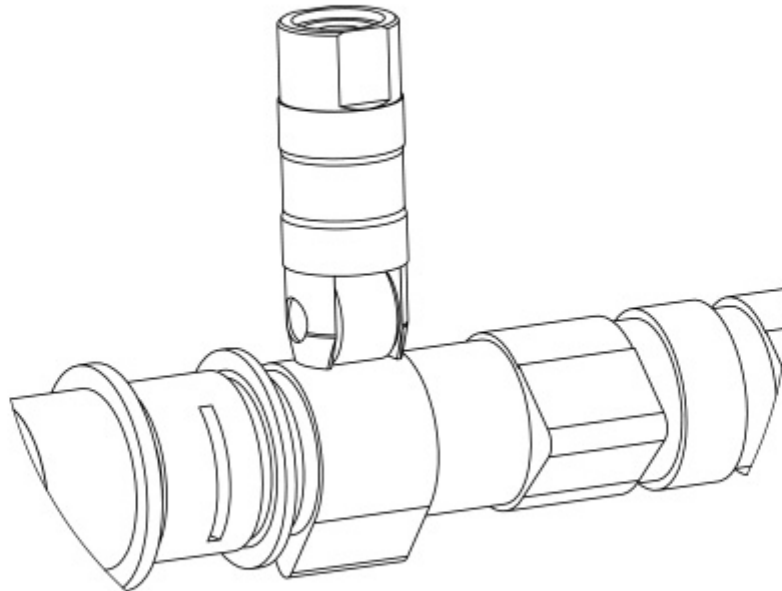

Many methods can be followed to ensure that the roller lifter is in the correct position before the valve lash or lifter preload is set. We recommend working with one cylinder at a time and using the cylinder at TDC method. This method ensures that both valves are completely closed before they are adjusted. (Note: this method may not be appropriate for applications with aggressive camshaft due to valve overlap. In such applications, follow the valve adjustment procedure outlined by the manufacturer.)

Set the piston of the cylinder being adjusted at top dead center (TDC), and then adjust both (intake and exhaust) valves for that cylinder. The process is then repeated until all of the valves have been adjusted. (*Tip: remove spark plug from cylinder so you are not working against cylinder compression. Use a ratchet/socket of a suitable size to rotate the engine in the normal direction by rotating the harmonic balancer bolt.*)

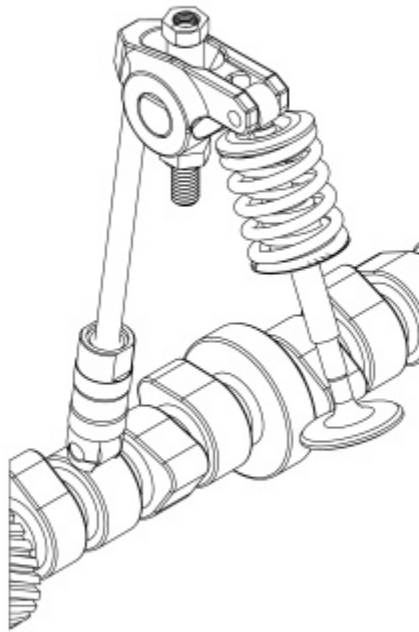

Hydraulic Lifter Adjustment Guide:

- Rotate engine manually until the piston (of adjusted cylinder) is at TDC.
- Ensure that the pushrod ends are well lubricated and seated properly at both ends.
- Loosen the posi-lock on the intake valve rocker arm. There should be no pressure on the rocker arm at this stage.
- With two fingers, spin the push rod back and forth while tightening the posi-lock. Feel for resistance in the pushrod.
- Carefully tighten the posi-lock and stop as soon as resistance is felt in the pushrod as it applies pressure on both sockets in the lifter and rocker arm. This is referred to as zero lash.
- Once the zero lash position is achieved, use an appropriate tool to tighten the posi-lock an extra $\frac{1}{2}$ turn (OR follow specific lifter manufacturer preload instructions) to preload the hydraulic lifter.
- Lock the posi-lock in position with lock nut or socket set screw.
- The preload adjustment for the intake valve is now complete.
- Without rotating the engine, repeat the above steps to adjust the preload on the exhaust valve.
- The intake and exhaust valve preload adjustment is now complete for the cylinder. Repeat the process to the remaining cylinders in the engine.
- It is good practice to double check all preload once all of the intake and exhaust valves have been adjusted.
- Obtain cam spec card or manufacturer instructions for correct valve lash specifications.
- Rotate engine manually until the piston (of adjusted cylinder) is at TDC.
- Ensure that the pushrod ends are well lubricated and seated properly at both ends.
- Loosen the posi-lock on the intake valve rocker arm. There should be no pressure on the

- rocker arm at this stage.
- Insert the correct feeler gauge in between the rocker arm tip and valve stem.
 - Tighten the posi-lock on the rocker arm until there is a slight drag when moving the feeler gauge.
 - Lock the posi-lock in position with lock nut or socket set screw.
 - The valve lash adjustment for the intake valve is now complete.
 - Without rotating the engine, repeat the above steps to adjust the valve lash on the exhaust valve.
 - The intake and exhaust valve lash adjustment is now complete for the cylinder. Repeat the process to the remaining cylinders in the engine.
 - It is good practice to double check all valve lash once all of the intake and exhaust valves have been adjusted.

Solid Lifter Adjustment Guide:

For all applications, follow OEM torque specs on all fasteners. It is critical to ensure that correct rocker arm geometry is achieved. The pushrod length must be adjusted to achieve the proper rocker arm geometry. It is essential to use the pushrod length checker tool to confirm the correct pushrod length. Speedmaster supplies different pushrod lengths to suit many applications.

Once all of the rocker arms are installed and the valve lash or preload have been set, rotate the engine manually and visually check for any clearance issues in the valve train. The smallest amount of clearance occurs when the valve is closed and the lifter on the base circle of the camshaft. Always hand turn the crank to verify there is adequate clearance of the rocker arm throughout the entire travel of the valve.

Certain applications may not have enough clearance between the rocker arm and valve cover after the installation of this kit. Once the valve lash or roller preload is set, place the valve cover in the correct position on the cylinder head without a gasket and hold it in position by hand and gently turn the engine over manually. Any movement of the valve cover or noise caused by contact with the rocker arms can then be noted and corrected before final assembly. If there is any interference, it can be corrected by modifying the valve cover or installing a taller aftermarket valve cover. At no point should the rocker arms be modified to suit the valve cover.

Before the valve covers are installed, pour an adequate amount of engine oil over the valve train especially the rocker arms and roller tips. This is necessary to ensure proper lubrication until the engine is started and oil travels through the engine as per normal.

Special Instructions

Having proper valve train geometry is critical to the valve train being durable and functional as intended. The tip of the rocker arm roller should operate around the centreline of the valve stem when the rocker arm opens the valve. Locating the rocker arm properly is achieved by moving mounting points, combining different length pushrods and valve stems or changing rocker arms.

The theoretical ratio is the distance from the point where the rocker arm roller tip touches the valve to the fulcrum centreline, divided by the distance from the center of the pushrod cup or adjusting screw to the fulcrum centreline. Since valve trains have many components, deflection and production tolerances will usually affect the actual amount of valve lift. As a result, the theoretical ratio will usually be slightly different to the rated ratio of the rocker arm. For this reason, it is always a good idea to check the lift of each valve to confirm whether the valve lift is the same on all of the cylinders.

The roller tip should ideally contact the valve stem center when the valve is half lift. If it contacts the stem towards the outside of the head, the pushrod is too long or if the contact is toward the fulcrum, the pushrod is too short.

Most importantly the contact patch on the valve tip should be between 1.5mm to 2mm (0.060"-0.080") wide. Valve guide side loading is a result of excessive roller tip lateral movement and not simply the position of the valve tip contact. As shown below, a narrow contact patch slightly off valve center is preferred to a wide contact in the center of the valve.

The easiest way to check roller/valve tip relationship is to apply a very light smear of "bearing blue" or colour the top of the valve stem with a Sharpie. Then, carefully assemble the rocker arms to the cylinder head. Once the valve has opened and closed, the contact patch of the roller will be clearly visible. The contact patch should be as close as possible to the center of the valve stem and as thin as possible to minimise side loading on the valve. Lash caps may be used to alter rocker arm geometry as an alternative to changing the pushrods.